

**Naval Facilities Engineering Command**

200 Stovall Street  
Alexandria, Virginia 22332-2300

APPROVED FOR PUBLIC RELEASE



**A FIELD GUIDE  
FOR THE  
Receipt And Inspection  
Of  
Treated Wood  
Products  
By Installation Personnel**

**NAVFAC MO-312.2**

**APRIL 1991**

SNDL DISTRIBUTION

(25 copies each):

FKA1C COMNAVFACENGCOM FKN1 EFDs

(10 Copies each):

FA46 PWCLANT FKN3 OICCS  
FB54 PWCPAC FKP7 NAVSHIPYDs  
ET104 PWCCNET

HQ U.S. AIR FORCE U.S. ARMY  
Engineering and Services Center Office Chief of Engineers  
Tyndall AFB, FL 32403 Washington, D. C 20314 (DAEN-MPO)

(2 copies each)

E3A	LABONR	FKM12	NAVPETOFF
FA6	NASLANT	FKM13	SPCC
FA7	NAVSTALANT	FKN2	CBCs
FA10	SUBASELANT	FKN7	NEESA
FA18	NAVPHIBASELANT	FKN10	NAVSUPPFAC
FA24	COMNAVBASELANT	FKN11	NAVCIVENGRLAB
FB7	NASPAC	FKP1B	WPNSTAs
FB10	NAVSTAPAC	FKP1J	NAVORDSTAs
FB13	SUBASEPAC	FKP16	NAVSSSES
FB21	NAVPHIBASEPAC	FKR1A	NAS
FB28	COMNAVBASEPAC	FKR1B	NAVAVNDEPOT
FB30	NAVSHIPREPFAC	FKR3A	NAVAIRENGCEN
FB36	NAVFACPAC	FR3	NASRESFOR
FB45	TRIREFFACPAC	FR4	NAF
FC3	COMNAVACTEUR	FT6	NASCNET
FC5	NAVSUPACTEUR	FT9	NAVAVMUSEUM
FC7	NAVSTAEUR	FT13	NATTC
FC14	NASEUR	FT28	NETC
FD4	OCEANCEN	FT31	NTC
FF1	COMNAVDIST Washington,D.C	FT37	NAVSCOLCECOFF
FF3	NAVSTACNO	FT38	NAVSUBTRACENPAC
FF6	NAVOBSY	FT39	NAVTECHTRACEN
FF32	FLDSUPPACT	FT55	NAVSCSCOL
FF38	USNA	V3	COMCAB
FF42	NAVPGSCOL	V4	MCAF
FG2	NAVCOMMSTA	V5	MCAS
FH3	NAVHOSP	V8	CG MCRD
FJA4	NAVAL HOME	V16	CG MCB
FKA8F5	SUBASE	V23	CG MCLB
FKM9	NSC		

Additional Copies may be obtained from:

Naval Publications and Forms Center  
5801 Tabor Avenue  
Philadelphia, PA 19120

## FOREWORD

The Navy has a multi-billion dollar investment in wood products which are incorporated into structures such as buildings, piers, utility plants, antenna systems and rail lines. Wood products are also used in numerous other applications which support military operations.

The importance of preservative treatment quality in wood product performance has long been recognized by the Navy. This field guide has therefore been developed in support of the Navy's quest to continually improve product quality and performance.

This guide is designed to assist installation personnel involved in the inspection and receipt of treated wood products. This guide uses a step by step process to determine the acceptability of treated wood products. If closely followed, users can be confident that materials accepted under the guidelines of this handbook will be of acceptable quality and will perform adequately.

Additional information or suggestions that will improve this handbook are invited and should be submitted through appropriate channels to the Naval Facilities Engineering Command, (Attention: Code 1632), 200 Stovall Street, Alexandria, VA 22332-2300.

This publication has been reviewed in accordance with the Secretary of the Navy Instruction 5600.16A and is certified as an official publication of the Naval Facilities Engineering Command.



E. R. HAMM  
CAPTAIN, CEC, U.S. Navy  
Assistant Commander for  
Public Works Centers and Departments



## **ABSTRACT**

This publication provides information which will help Navy personnel ensure that they receive preservative treated wood products of acceptable quality, which will in turn help ensure acceptable product performance.

Specific areas covered by this guide include; procedures for acceptance or rejection, branding, inspection reports, wood species, physical condition, incising, preservative treatment (penetration and retention), and a directory for professional assistance.









## Table of Contents

---

A FIELD GUIDE FOR THE RECEIPT AND INSPECTION OF TREATED WOOD PRODUCTS BY INSTALLATION PERSONNEL . . . . .	1-1
INTRODUCTION . . . . .	1-1
BACKGROUND . . . . .	1- 1
GENERAL . . . . .	1- 1
INSTRUCTIONS FOR USE OF THE KEY TO ACCEPTANCE OR REJECTION OF PRESSURE TREATED WOOD PRODUCTS . . . . .	1-2
LONG-FORM AND SHORT-FORM KEYS . . . . .	1-2
Part I . . . . .	1- 2
Part II . . . . .	1-2
APPENDICES . . . . .	1-3
SHORT-FORM KEY TO ACCEPTANCE OR REJECTION OF PRESSURE-PRESERVATIVE TREATED WOOD PRODUCTS . . . . .	1-4
Part I . . . . .	1- 4
Part II . . . . .	1-6
LONG-FORM KEY TO ACCEPTANCE OR REJECTION OF PRESSURE-PRESERVATIVE TREATED WOOD PRODUCTS . . . . .	1-8
Part I . . . . .	1- 8
Part II . . . . .	1-17
Appendix A Naval Facilities Engineering Command Applied Biologists . . . . .	A-1
Appendix B American Wood-Preserver's Association Standard M6-88 Brands Used on Forest Products . . . . .	B-1
Appendix C	
Table 1: Marine Piling . . . . .	C-1
Table 2: Land and Fresh Water Piling . . . . .	C-3
Table 3: Foundation Piling . . . . .	C-5

Table 4: Lumber, Timber, and Plywood For Non-Marine Use . . . . .	C-7
Table 5: Lumber, Timber, and Plywood For Marine Use . . . . .	C-10
Table 6: Poles . . . . .	C-12
Table 7: Crossties and Switch Ties . . . . .	C-14
Appendix D Wood Products Inspection Scope of Work . . . . .	D-1
Appendix E Boring Sample Report . . . . .	E-1

A FIELD GUIDE FOR THE RECEIPT AND  
INSPECTION OF TREATED WOOD PRODUCTS  
BY INSTALLATION PERSONNEL

**INTRODUCTION.** This guide is designed to assist installation personnel who are required to receive, verify, and accept pressure-preservative treated wood products that are delivered to the installation. The guide provides basic guidelines for accepting or rejecting a product.

**BACKGROUND.** During 1985-86, a joint Navy-American Wood Preservers' Bureau (AWPB) program surveyed 18 Naval installations which were major wood users. The survey revealed that a majority of the delivered products did not conform to treatment standards or contract specifications. Most of the nonconforming materials had not received the required quality control inspections by the producer. Many of the products were not branded or marked as required, which frequently led to the misuse of those products. Other problems included substitutions of specified wood species and products not treated to specification. On those occasions when required inspection reports were provided, the reports were not correct and were possibly falsified. Many of the problems were caused by a general lack of knowledge by Navy personnel about pressure treated wood and were especially caused by the lack of good inspection at the installation.

**GENERAL.** This guide is designed to assist naval installation personnel in inspecting treated wood products that are delivered to the installation to determine if those products are acceptable for use. The Guide consists of a **KEY** that contains two parts, one for personnel with little or no training or experience with wood products, and a second for those personnel with training, experience, and the equipment to conduct detailed inspection. The **KEY** is in 2 forms - a long form with explanations and a short form without explanations. The **KEY** allows even the inexperienced person to proceed in a logical step-by-step procedure to either accept or reject delivered products. Also, the Guide contains several Appendices which give the inspector additional information to supplement the long-form **KEY**.

Wood products must be treated with preservatives so that they will not rot or decompose. When working with treated wood products, installation personnel should recognize that there is a great deal of variability be-

tween, and even within, wood species. For instance, there is a great deal of difference between the properties of red oaks and white oaks. The preservative treatment process increases the variability even more. Because of this variability, constant quality control by the treater and quality assurance by the user are essential. This Guide will only be effective if each naval installation periodically conducts an overview of the wood procurement program to determine the effectiveness of treaters, inspection agencies, and inspection reports. Government overviews can be accomplished through the use of trained government inspectors or by contracting with one of the EFD recommended independent inspection agencies.

**INSTRUCTIONS FOR USE OF THE KEY TO ACCEPTANCE OR REJECTION OF PRESSURE TREATED WOOD PRODUCTS.** The KEY leads the naval installation inspector through a series of decision making steps to either accept or reject delivered products or to obtain a more detailed inspection. The inspection process depends largely on the presence of brands or marks on the products and on the inspection reports submitted with the products. Products must be properly marked and must have inspection reports.

**LONG-FORM AND SHORT-FORM KEYS.** There are two versions of the KEY -- the long-form KEY and the short-form KEY. The steps are the same in both forms, but the long-form KEY has more explanations than the short-form KEY. Naval installation inspectors should use the long-form KEY until they are thoroughly familiar with the inspection process. Once inspectors are comfortable with the process, they may want to use the short-form KEY which does not have detailed explanations.

**PART I.** The KEY is divided into PARTS I and II. PART I is to help any installation inspector perform certain observations that will lead to a decision. The steps will lead the inspector to a decision to accept or reject the products or to proceed to the next step. At the end of PART I, if the inspector has not accepted or rejected the product, the inspector should proceed to PART II. If at any time during the inspection the inspector has doubt concerning the product, the treatment, or the independent inspection agency report, the EFD Applied Biologist should be consulted. Appendix A provides EFD Applied Biology contact persons for treated wood.

**PART II.** This part of the inspection process should only be performed

by trained personnel with the equipment to obtain samples by boring, to determine preservative penetration, and to obtain analyses for preservative retention. If trained government personnel are not available to perform this part of the inspection, then one of a number of independent agencies, recommended by an EFD Applied Biologist, should be hired to determine if the products conform to treatment standards and the contract specifications.

APPENDICES. This guide contains several Appendices that have additional information to help the inspector make a decision. The inspector should be thoroughly familiar with the information in the Appendices and should refer to the appropriate Appendix whenever the Appendix is mentioned in the KEY.

Before inspecting any treated wood products, the inspector must have in his/her possession a copy of the contract specification requirements for the treated wood. The specification will indicate whether the product was purchased through the Federal Supply System at the Defense Construction Supply Center (DCSC), through local purchase, or through a construction or repair contractor. The specification will also tell the inspector the requirements for the species of wood, its intended use, preservative treatment, special conditioning, Acceptable Quality Marks or other brands, and (if appropriate) the class and/or grade of the product.

NOTE: If the materials are not inspected within 90 days of delivery, the naval installation will lose the right to protest about the materials.

SHORT-FORM KEY  
 TO ACCEPTANCE OR REJECTION  
 OF PRESSURE-PRESERVATIVE TREATED WOOD PRODUCTS

<b>Step</b>	<b>Inspection Categories</b>	<b>Possible Situations</b>	<b>Long Form Key Reference</b>	<b>Action</b>
<u>Part I</u>				
1	Product Source	a. DLA Contract-identified by DLA Marks on item or bundle	Par. 1a	Verify species, treatment and item count, then ACCEPT
		b. Local Purchase	Par. 1b	Go to Step 2
		c. Construction Contractor	Par. 1c	Go to Step 2
2	Brand	a. No brands, tags, or other marks	Par. 2	REJECT
		b. Has brands, tags, or other marks	Par. 2	Go to Step 3
3	Quality Control	a. Has “Acceptable” Quality Marks (AWPB, WQC or SPIB)	Par. 3	Verify species, treatment and item count, then ACCEPT
		b. No “Acceptable” Quality Marks	Par. 3	Go to Step 4

SHORT-FORM KEY TO ACCEPTANCE OR REJECTION OF  
PRESSURE-PRESERVATIVE  
TREATED WOOD PRODUCTS (CONT.)

<b>Step</b>	<b>Inspection Categories</b>	<b>Possible Situations</b>	<b>Long Form Key Reference</b>	<b>Action</b>
4	Inspection Report	a. No inspection report from approved independent inspection agency	Par. 4	REJECT
		b. Has inspection report	Par. 4	Go to Step 5
5	Species	a. Wrong Species	Par.5	REJECT
		b. Right Species	Par.5	Go to Step 6
6	Physical Condition	a. Unacceptable or railroad ties without anti-splitting devices	Par. 6	REJECT
		b. Acceptable or railroad ties with anti-splitting devices	Par. 6	Go to Step 7
7	Preservative Treatments (Douglas Fir & all hardwoods)	a. Not incised prior to treatment	Par. 7	REJECT
		b. Incised prior to treatment	Par. 7	Go to Step 8
8	Type of Treatment	a. Not as specified or no bore holes	Par. 8	REJECT

SHORT-FORM KEY TO ACCEPTANCE OR REJECTION OF  
PRESSURE-PRESERVATIVE  
TREATED WOOD PRODUCTS (CONT.)

<b>Step</b>	<b>Inspection Categories</b>	<b>Possible Situations</b>	<b>Long Form Key Reference</b>	<b>Action</b>
		b. As specified with bore holes	Par. 8	Go to Step 9
9	Inspector Confidence	a. Any doubts about Par. 9 acceptability of product		Consult EFD Applied Biologist
		b. Doubts after consulting biologist	Par. 9	Go to Part II
		c. You are confident that product is satisfactory	Par. 9	ACCEPT

PART II

NOTE: The next two inspection steps should only be attempted by trained personnel or by an Independent Inspection Agency recommended by the EFD Applied Biologist. Procedures for sampling for penetration and retention shall be in accordance with the latest issue of AWPA Standard M2.

<b>Step</b>	<b>Inspection Categories</b>	<b>Possible Situations</b>	<b>Long-Form Key Reference</b>	<b>Action</b>
10	Preservative Penetration	a. Not as specified b. As specified	Par. 10 Par. 10	REJECT Go to Step 11



<b>Step</b>	<b>Inspection Categories</b>	<b>Possible Situations</b>	<b>Long-Form Key Reference</b>	<b>Action</b>
11	Preservative Retention	a. Not as specified b. As specified	Par. 11 Par. 11	REJECT ACCEPT

NOTE: The supplier should be required to remove rejected materials within 30 days of notification of rejection.

LONG-FORM KEY TO ACCEPTANCE OR REJECTION OF  
PRESSURE-PRESERVATIVE TREATED  
WOOD PRODUCTS

PART I

Step 1. Sources of Treated Wood Products.

a. **DLA Contract.** The naval installation supply office orders products through the Defense Construction Supply Center (DCSC) in Columbus, Ohio. At DCSC, orders are reviewed for technical accuracy then placed with a contractor supplier/producer. The Defense Contracts Administration Service Regional Office (DCASR) then arranges for the inspection and acceptance (Quality Assurance) of these products prior to delivery. Products supplied through this system will be identified by DLA Marks printed or attached to each item or several items of a bundle. DLA Marks may be a DLA number such as DLA-720-87-C-4568 or DLA-720-87-M-4569 or a NSN number such as NSN-5510-00-263--923. The combination of numbers and letters that make up a DLA number indicates the following about the product:

---

Designation for Wood Products	720
Year of Treatment	87
Contract Value Over \$25,000	C
Or	
Contract Value Less Than \$25,000	M
4-Digit Contract	4568

---

In a NSN number, all of the numbers refer to the product's identity as indicated in the most recent issue of the DLA Manual LMP-04, Lumber, Millwork, and Plywood. A copy of the DLA Manual LMP-04 should be available at the installation supply office or it may be obtained from the Defense Logistics Service DLSC-WP, Battle Creek, MI 49017-3084. Telephone: DSN 932-4880, or commercial (616) 961-4880. The Manual contains valuable information concerning the identity of products and provides points of contact concerning any aspect of the procurement pro-

cedure.

Each DLA shipment should include a DD Form 250, Material Inspection and Receiving Report. When you inspect and approve the material, you should sign the report as the DCASR-Quality Assurance Representative (QAR).

**ACTION:**           Verify the species, treatment, and item count.....  
**ACCEPT.**

b. **Local Purchase.** Products which cost less than \$2,500 are usually ordered from a local supplier/producer. These products must be checked carefully. You should check that an inspection report is submitted by an approved independent inspection agency. The report should verify treatment and compliance with the specification.

**ACTION:**           Proceed to Step 2.

c. **Construction Contractor.** These are products obtained and installed by construction or repair contractors. These products also must be checked carefully. The contractor is responsible for the quality of the product and is required to produce proof of inspection by an approved independent inspection agency. NOTE: Instead of an inspection, the contractor may provide softwood products bearing an "Acceptable" Quality Mark, such as AWPB, SPIB, WQC and others as they become available. Products bearing an acceptable quality mark are quality-assured. If you have any doubt concerning a product, treater, or inspection agency, you should request a detailed inspection as in PART II. The EFD Applied Biologist is available to provide information concerning such overview inspections.

**ACTION:**           Proceed to Step 2.

## Step 2. Brands Used on Treated Wood Products.

The American Wood Preservers' Association (AWPA) M-6 Standard (Appendix B) indicates specific information that must be marked, branded, or tagged on each piece of treated material. If a bundle contains small pieces of lumber, only the outside pieces of the bundle must

be marked instead of each piece. This applies if the lumber is 1" X 4" or less in size, less than 2" X 4" in size, or 36" or less in length.

Typical Brand Information will include the following:

Supplier's Brand (Trademark)	ABCO	
Plant Designation	D	- May be Combined
Year of Treatment	86	- As D-86
Species of Timber and Preservative Treatment (eg, southern pine - creosote)	SPC	
Preservative Retention(s)(eg, 8 lb./cu. ft.)	8	
Class and Length (eg, Class 7 - 30 ft. long)	7-30	

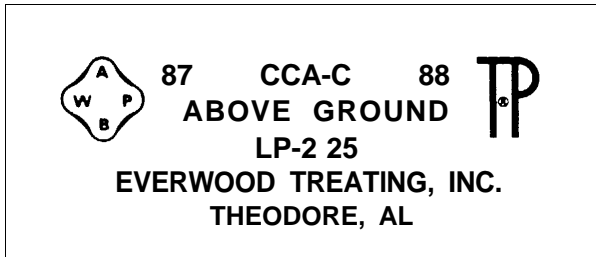

Typical Label for Treated Wood

You should locate the specific product table in Appendix C to rapidly identify the brand information.

**ACTION:** No brands or suitable marks ..... **REJECT.**

Has proper brands or marks ..... Proceed to Step 3.

### Step 3. Acceptable Quality Marks.

Many treating plants have quality control programs. These plants mark their products with Quality Marks or brands. The American Wood Preservers' Bureau (AWPB) sets quality control procedures to guarantee quality in most softwood products such as lumber, timber, plywood, and piling. The AWPB standards are recognized by treaters, certified independent inspection agencies, and Bureau inspectors. A "Clover-leaf" mark on the product indicates AWPB approval (eg, label illustrated in Step 2 above). The mark may appear by itself or with the treater's brand.

The Rural Electrification Administration (REA) has a quality control program followed by many treating plants that produce utility poles. Approval by this program is shown by a "WQC" mark plus the treater's brand mark. "WQC" means Wood Quality Control.

The Southern Pine Inspection Bureau also utilizes a quality mark to indicate that the product conforms to AWPA Treatment Standards. The "SPIB" mark is their quality mark.

Products displaying the “Cloverleaf”, WQC, or SPIB Branding Marks may be accepted without further inspection. Because Acceptable Quality Marks may change from time to time, you are encouraged to periodically contact a EFD Applied Biologist for an updated list.

**ACTION:** Products with “Cloverleaf,” WQC or SPIB Marks: verify species, treatment, and item count.....

**ACCEPT**

Products without Acceptable Quality Mark.....  
Proceed to Step 4.

### Step 3. Inspection Reports.

An inspection report should be delivered with the lumber. The inspection report plus the product’s brand will help you complete your inspection. All softwood products without an Acceptable Quality Mark must be accompanied by an inspection report from an approved independent inspection agency. The report must verify that the products meet the naval installation’s specifications and that the products meet AWWA Standards or other specified standards. The independent inspection agency inspection should be in accordance with AWWA Standard M2, and each piece of treated wood should bear the inspector’s hammer mark on one or both ends. The inspection report shall include all of the following applicable information, plus any other information requested by the installation:

Name of Treating Company

Location of Treating Plant

Applicable Product Specification or Standard (ASTM, AWWA, AWPB, Contract)

Charge number (Many pieces of wood are placed in a cylinder and treated with preservative. Each cylinder full of wood is called a charge and is assigned a charge number.)

Date of treatment

Contents of charge

Type of material (poles, piles, lumber, etc.) Number of pieces by size  
Species  
Degree of seasoning  
Manufacturing (incised, unincised, rough surfaces, etc.) Number of  
cubic feet

Preservative

Process used in treatment  
Steam conditioning  
Time required to reach maximum temperature  
Time steamed at maximum temperature  
Maximum temperature  
Total condensation  
Total absorption of preservative  
Initial air pressure  
Initial air period  
Pressure period  
Maximum temperature  
Average temperature

Final vacuum period

Time & temperature of final steam bath (if any)  
Time & temperature of expansion bath (if any)

Working tank readings with temperature

Injection under pressure  
Final retention  
Total time of treatment

Penetration

Number of borings taken  
Percent conforming  
Most important to the inspector for determining treatment  
conformance

The important items will be discussed in the following KEY Steps and in  
the product tables of Appendix C.

ACTION:           Items without inspection report .... **REJECT**

                          Items with inspection report .... Proceed to Step 5

## Step 5. Species.

The species of wood is specified in the contract. Check the inspection report under Contents of Charge to make certain that the wood is the species required by the contract. Also, examine the brands on several pieces to see if they match the inspection report, and the contract specification. (Check the product tables of Appendix C to identify the acceptable species codes for specific commodities.)

**ACTION:** Species do not match inspection report and contract...  
**REJECT.**

Species are correct .... Proceed to Step 6.

## Step 6. Physical Condition.

You must visually inspect the physical condition of the wood. Major defects in the wood should have been found and removed prior to treatment. However breaks, checking, and splitting can occur after treatment.

With any wood product, a certain amount of checking will occur as the wood seasons. Checks are separations along the grain of the wood. Checks are allowable.

A split is a check that extends entirely through a piece of wood from one surface to another surface. With poles and piles, splits in the butt (larger end) are permitted if they do not extend more than two feet on the side surface. For seasoned milled lumber and railroad ties, splits shall not be longer than 4" at either end. In addition, splits in railroad ties shall not be wider than 1/4".

Railroad ties with splits longer than 4", but not longer than the width of the face in which the split appears, may be made acceptable if the supplier installs anti-splitting devices. These devices are installed while the wood is in a compressed state to keep the split from reopening or enlarging. Two types of anti-splitting metal devices are acceptable (unless otherwise specified): the end plate (figure 1), which is installed at the end of a piece, or 2 dowels (figure 2) installed 3-5" from the end and 2"-2 1/2" from the top, bottom, or side.



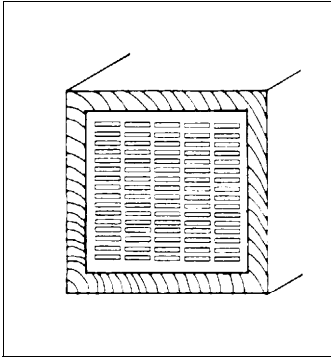

Figure 1

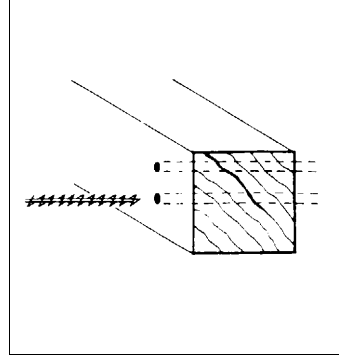

Figure 2

NOTE: End plates shall be galvanized steel with teeth at least 9/16" long and shall be a minimum 6" X 7 1/2" for main line ties, and 5" X 6 1/4" for side track ties.

ACTION: Materials broken or damaged in shipment,...  
**REJECT.**

Materials with unacceptable splits, checks or in poor condition ..... **REJECT.**

Railroad ties with unacceptable splits and without anti-splitting devices .... **REJECT.**

Materials in acceptable condition or railroad ties with anti-splitting devices ... Proceed to Step 7.

#### Step 7. Incising.

Incising is small holes mechanically put in the wood before treatment so that the preservative can penetrate the wood evenly. The holes may vary in size from a pin hole to a cut 1/2" or longer and may be as deep as 3/4". Because incising is done by machine, a definite pattern will be recognized. Any piece of lumber over 2" thick must be incised. The Contents of Charge portion of the inspection report will indicate if incising was performed. If incising is required, you should visually check the products for incising holes.

**ACTION:** Lumber over 2” thick without incising holes .... **REJECT.**

Lumber over 2” thick with incising holes .... Proceed to Step 8.

#### Step 8. Treatment

Treatment requires penetration (depth) and retention (amount injected) of the required preservative in accordance with the latest issue of specified AWPAs standards. The product’s effectiveness will depend most on the depth of penetration and the amount of preservative injected into the product. The treater should have bored samples from the wood and tested the wood for penetration and retention. The holes from the boring samples should be plugged with preservative treated hardwood dowels approximately 1/3” in diameter.

Since most borings will be taken from the outer pieces in a charge, the bore holes should be easily found if the lot was not opened. Check the product’s brand to determine if the preservative matches the independent inspection agency’s report and the contract specification. Also check near the middle of pieces of wood for evidence of sample borings.

**ACTION:** Product has not had correct treatment or does not have plugged bore holes .... **REJECT.**

Product has had correct treatment and has bore plugged holes .... Proceed to Step 9.

#### Step 9. Inspector Confidence in the Product.

At this point in the inspection process, you should have enough information to accept or reject a product. If you are in doubt about items such as treatment, prior inspections, physical quality, etc., you should request a final inspection by a trained wood inspector. Doubt may be caused by a lack of experience with a particular producer or with the independent inspection agency which inspected a product, especially if evidence of inspection is lacking. When in doubt, you should consult with the EFD Applied Biologist (Appendix A). If confidence is still lacking after consulting with the biologist, you should proceed to Part II. If you are confident that the products are satisfactory, **ACCEPT** the products.

**ACTION:** Any doubts about acceptability of product .... Consult EFD Applied Biologist.

Doubts after consulting biologist .... Proceed to Part II.

Total confidence in product ... **ACCEPT.**

## LONG-FORM KEY PART II

**NOTE:** This part of the inspection procedure shall only be performed by trained personnel because it requires the collection and shipment of sample borings to a laboratory for analysis. If trained government personnel (either DCASR, EFD, or installation) are not available to take borings, then the EFD Applied Biologist should be consulted to provide a recommendation for an independent inspection agency to conduct final inspection. The EFD Applied Biologist will also provide details concerning the analytical laboratory where cores should be sent. A guide scope of work for wood products inspection is provided as Appendix D. Final inspection shall be in accordance with AWPA Standard M2, and the appropriate AWPA Commodity (C) Standard. A boring sample report, as in Appendix E, or equivalent, should be submitted along with the cores to the analytical laboratory. The laboratory will provide information results by telephone within 24 hours of receipt of the cores. The laboratory will then complete the analysis portion of the report and send it back to the installation for disposition.

Step 10. Preservative Penetration.

The preservative penetration must be as specified in the appropriate AWPA “C” Standard.

**ACTION:** Preservative penetration not as specified .... **REJECT.**

Preservative penetration meets AWPA “C” Standard .... Proceed to Step 11.

Step 11. Preservative Retention.

The preservative retention must be as specified in the appropriate AWPA “C” Standard.

**ACTION:** Preservative retention not as specified in AWPA “C” Standard .... **REJECT.**

Preservative retention conforms to AWPA “C” Standard .... **ACCEPT.**

When a product is rejected, the inspector should note and record the producer/supplier and independent inspection agency involved.

The EFD Applied Biologist should be consulted to determine if further action should be taken. This information also will be useful in determining confidence in future dealings with a producer or inspection agency.

**NOTE:** The supplier should remove rejected products from the installation within 30 days of notification of rejection. The supplier should also be assessed all charges for destination inspection when the results of each destination inspection result in product rejection.

## Appendix A

### NAVAL FACILITIES ENGINEERING COMMAND APPLIED BIOLOGISTS

Office	Personnel	Area of Responsibility
Applied Biology Program (1634) Naval Facilities Engineering Command, 200 Stovall Street Alexandria, VA 22332-2300 703/325-0045, DSN 221-4045, FAX 703/325-6904	Mr. William A. Gebhart (1634) Dr. Peter J. Egan (1634A) (Wood Protection)	Navy-wide
Atlantic Division (161) Naval Facilities Engineering Command Norfolk, VA 23511-6287	Dr. Daniel G. Maiello (161A) 804/444-9581, 9546 DSN 564-9581, 9546	Virginia, North Carolina, Kentucky, West Virginia, Argentina, Newfoundland Iceland, United Kingdom, West Germany, Greece, Italy, Morocco, Spain, Azores, Antigua, Barbados, Trinidad, Turks Caicos, Bermuda, Puerto Rico, Panama
Pacific Division (114A) Naval Facilities Engineering Command Pearl Harbor, HI 96860-7300 808/471-3948	Mr. Lawrence Pinter (808/474-5961) Dr. Stanley Y. Higa (808/474-5956) (wood protection)	Hawaii, Midway, Guam, Phillippines, Okinawa, Japan, Australia, Bahrain Diego Garcia
Northern Division (164) Naval Facilities Engineering Command Philadelphia, PA 19112-5094 215/897-6057, DSN 443-6417  (143)	Mr. Peter L. Fish (Navy-Wide Wood Protection) 215/897-6688, DSN 443  Mr. Thomas C. Walker Mr. Stephen Kincaid Mr. Jeff Davis Mr. Simeon Hahn 215/897-6057, DSN 443	Maine, New Hampshire, Vermont, Massachusetts, New York, Illinois, Indiana, New Jersey, Pennsylvania, Delaware, Ohio, Maryland, Virginia, Connecticut, Michigan, Wisconsin, Minnesota, Iowa, Missouri, Kansas, Nebraska, North Dakota, South Dakota, Colorado, District of Columbia, Rhode Island
(Northern Division also supports Chesapeake Division installations)		

Office	Personnel	Area of Responsibility
Southern Division (16A) Naval Facilities Engineering Command, P.O. Box 10068 Charleston, SC 29411-0068 803/743-0508, 10, 11 DSN 563-0508, 10, 11	Mr. C. W. Bennett (16A) (wood protection) Mr. Melvin P. Marks (16A1) Mrs. Sharon E. Bartku (16A2)	North Carolina, South Carolina, Georgia, Florida, Alabama, Louisiana, Mississippi, Tennessee, Texas, Arkansas, Oklahoma, New Mexico, & Andros Island (Bahamas)
Western Division (162A) Naval Facilities Engineering Command, P.O. Box 727 San Bruno, CA 94066-0720 415/244-3572,3 DSN 494-3572,3	Mr. A. Reese Christopherson Mr. Scott Dombrosky (wood protection)	Alaska, Arizona, California Idaho, Montana, Nevada, Oregon, Washington, Wyoming, Utah
(Western Division also supports Southwest Division installations)		
Commanding Officer (410E) U.S. Navy Public Works Center Subic Bay FPO San Francisco, CA 96651-2900 DSN 384-6292	Mr. Napoleon P. Camba	All U. S. Navy installations in the Phillipines
Commanding Officer (420E) U.S. Navy Public Works Center Box 13 FPO Seattle 98762 DSN 234-7414	Mr. Akira Masui	U. S. Navy installations in Japan (less Okinawa)

(Revised 23 Jan 1991)

## APPENDIX B

### AMERICAN WOOD-PRESERVERS' ASSOCIATION STANDARD

(The Standard is under the jurisdiction of AWPA Subcommittee T-7)  
**M6-88**

### BRANDS USED ON FOREST PRODUCTS

#### Typical Brand and Key<sup>1</sup>

ABCO	Supplier's Brand
D	Plant Designation
60	Year of Treatment <sup>2</sup>
SPC	Species of Timber and Preservative Treatment
----	Retentions <sup>3</sup>
7-30	Class and Length

#### Species

AS	Ashes
BE	Beech
BI	Birches
BW	Black Walnut
DF	Douglas Fir
EC	Northern White (Eastern) Cedar
ES	Engelmann Spruce
GU	Gum
HI	Hickories
JP	Jack Pine
LO	Locust
LP	Lodgepole Pine
MA	Maples
NP	Red Pine
OA	Oaks
RW	Redwood
SP	Southern Pine
SS	Sitka Spruce
WC	Western Red Cedar
WF	Western Firs
WH	Western Hemlock
WL	Western Larch (Western Tamarack)

WP	Ponderosa Pine
WS	White Spruce
YC	Alaska Yellow Cedar

## Preservatives<sup>4</sup>

### *Organic Preservatives*

C	Creosote
CM	Creosote for marine use
PB	Pentachlorophenol in Volatile Petroleum Solvent (LPG)
PC	Pentachlorophenol in Light Hydrocarbon Solvent
PD	Pentachlorophenol in Chlorinated Hydrocarbon Solvent
PA	Pentachlorophenol in petroleum
TA	80/20 Creosote-Coal Tar Solution
TB	70/30 Creosote-Coal Tar Solution
TC	60/40 Creosote-Coal Tar Solution
TD	50/50 Creosote-Coal Tar Solution
TM	Creosote-Coal Tar Solution for marine use
XA	80/20 Creosote-Petroleum Solution
XB	70/30 Creosote-Petroleum Solution
XC	60/40 Creosote-Petroleum Solution
SD	SO/50 Creosote-Petroleum Solution

Note: Double treatment, salt and creosote, letter "C" to be placed ahead of salt symbol. Where organic preservative is other than creosote, use the symbol for that preservative instead of the symbol for creosote.

### *Organometallic Preservatives*

B	Copper Naphthenate in creosote
N	Copper Naphthenate in petroleum
C8	Copper-8-Quinolinolate
TO	Tributyltin Oxide

### *Inorganic Preservatives*

SA	Acid Copper Chromate (ACC)
SB	Ammoniacal Copper Arsenate (ACA)
SC	Chromated Copper Arsenate (CCA Type A)
SE	Chromated Zinc Chloride (CZC)
SF	Copperized Chromated Zinc Arsenate (CuCZA)
SJ	Chromated Copper Arsenate (CCA Type B)



SK Chromated Copper Arsenate (CCA Type C)  
SZ Ammoniacal Copper Zinc Arsenate (ACZA)

---

<sup>1</sup>This information may be placed on the material in some other form and/or order, if so authorized by the purchaser.

<sup>2</sup>May also include month, as "10-60."

<sup>3</sup>If retention is determined by assay, place letter "A" after numeral.

<sup>4</sup>Full names or the abbreviations shown or trade names may be used for preservatives instead of the recommended standard symbols if desired.

**APPENDIX C**  
**TABLE 1: MARINE PILING**

Marine pilings are timbers, usually round, that will be used in or near salt water as a support for a pier or wharf, or as a dolphin or camel-log. Marine piles are generally subject to attack by marine organisms.

Treatment Standard: AWWA C3 - For Marine Piles

Brands: The producer shall brand each pile at points 5 feet and 10 feet from the butt end (larger end) of the pile. Each brand shall show as minimum:

<b>Brand Information</b>	<b>Code Letters</b>	<b>Example Interpretation</b>
Supplier's Brand	ABCO	Company name or logo
Plant Designation and Year of Treatment	D-86	Location & date treated
Species of Timber and Preservative Treatment	SPCM	Southern pine treated marine creosote
Preservative Retention(s)	20	20 pcf (per spec.)
Length	60	60 feet (per spec.)

**Code                      Acceptable Species**

SP	Southern Pine
DF	Coastal Douglas Fir

**Code                      Acceptable Preservatives (Check Specifications)**

C, CM, TM, CC	Creosote (Code indicates types of creosote)
SB	Ammoniacal Copper Arsenate (ACA)
SK, SC, SJ	Chromated Copper Arsenate (CCA)(Types C, A, B)
SZ	Ammoniacal Copper Zinc Arsenate (ACZA)
CSB, CSK, CSZ	Dual treated with creosote and waterborne preservative Creosote/ACA, Creosote/CCA Creosote/ACZA

Acceptable Quality Marks: The Quality Mark (AWPB, SPIB) shall be stamped on Monel-metal tags and permanently affixed, in a bored recess, on each treated pile midway between the producer's two brands.



**MP-1  
Dual  
Marine Piles**



**MP-2  
Creosote  
Marine Piles**



**MP-4  
Waterborne  
Marine Piles**

**AWPB**

- MP-1 Dual treated with a waterborne preservative and creosote
- MP-2 Treated with creosote
- MP-4 Treated with a waterborne preservative

**Typical Piling Mark**

ABCO  
87  
SPC  
12  
30

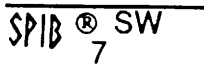

Note: Each pile must be bored by the producer or independent inspection agency inspector. The independent inspection agency report must indicate 100% conformance to standard.

**TABLE 2: LAND AND FRESH WATER PILING  
(ALSO REFERRED TO AS GENERAL USE PILING)**

Land and fresh water pilings are usually round, for use in fresh water or in soil, and may be partially embedded in the earth but not capped with masonry.

Treatment Standard: AWPA C3 -- for Land and Fresh Water Piles

Brands: The producer shall brand each pile at points 5 feet and 10 feet from butt end (larger end) of the pile. Each brand shall show as a minimum:

<b>Brand Information</b>	<b>Code Ltrs</b>	<b>Example Interpretation</b>
Supplier's Brand	ABCO	Company name or logo
Plant Designation and Year of Treatment	D-86	Location & date treated
Species of Timber and Preservative Treatment	DFSB	Douglas fir treated with ACA
Preservative Retention(s)	1	1 pcf (per spec.)
Length	40	40 feet (per spec.)

<b>Code</b>	<b>Acceptable Species</b>
SP	Southern Pine
DF	Coastal Douglas Fir
NP	Red (Norway) Pine

<b>Code</b>	<b>Acceptable Preservatives (Check Specifications)</b>
C, TA, TB, TC	Creosote (Code indicates types of creosote)
TD	
PC, PD, PA	Pentachlorophenol (in different solvents)
SB	Ammoniacal Copper Arsenate (ACA)
SK, SC, SJ	Chromated Copper Arsenate (CCA)
	(Types C,A,B)
SZ	Ammoniacal Copper Zinc Arsenate (ACZA)

Acceptable Quality marks: The Quality Mark (AWPB, SPIB) shall be stamped on monel-metal tags and permanently affixed, in a bored recess, on each treated pile midway between the producer's two brands.



CFP  
Foundatron  
Piles

Typical Piling Mark

ABCO  
87  
SPC  
12

SPIB ® SW  
7

**TABLE 3: FOUNDATION PILING (ALSO REFERRED TO AS BUILDING PILES)**

Foundation pilings are usually round, to be entirely embedded in the ground and capped with masonry.

Treatment Standard: AWPA C3 -- for Foundation Piles

Brands: The producer shall brand each pile at points 5 feet and 10 feet from butt end (larger circumference) of the pile. Each brand shall show as a minimum:

<b>Brand Information</b>	<b>Code Ltrs</b>	<b>Example Interpretation</b>
Supplier's Brand	ABCO	Company name or logo
Plant Designation and Year of Treatment	D-84	Location & date treated
Species of Timber and Preservative Treatment	SPC	Southern Pine treated with creosote
Preservative Retention(s)	12	12 pcf (Per spec.)
Length	30	30 feet (Per spec.)

**Code                      Acceptable Species**

SP	Southern Pine
DF	Coastal Douglas Fir
NP	Red (Norway) Pine

**Code                      Acceptable Preservatives (Check Specifications)**

C, TA, TB, TC, TD	Creosote (Code indicates types of creosotes)
SB	Ammoniacal Copper Arsenate (ACA)
SK, SC, SJ	Chromated Copper Arsenate (CCA) Types C,A,B)
SZ	Ammoniacal Copper Zinc Arsenate (ACZA)

Acceptable Quality Marks: The Quality Mark (AWPB, SPIB) shall be stamped on monel-metal tags and permanently affixed, in a bored recess, on each treated pile midway between the producer's two brands.



Typical Piling Mark

ABCO  
 87  
 SPC  
 12  
 30  

---

 SPIB® SW  
 7

Note: Pentachlorophenol is an acceptable preservative for treating foundation piles; however, it shall not be specified or used in or under buildings to be occupied by humans or animals. Therefore any product in which the preservative in the brand is identified as pentachlorophenol (PA, PB, PC, PD) shall be **REJECTED**.

**TABLE 4: LUMBER, TIMBER, AND PLYWOOD  
FOR NON-MARINE USE**

Lumber and timber are rectangular commodities sawn from logs. Lumber may be dressed (smooth planed) or rough (unplaned). Lumber is less than 2” in nominal thickness and may be called boards or strips. Dimension lumber is from 2” up to, but not including, 5” thick and may be called stringers, posts, girders, beams, etc. Plywood is a composite panel or board made up of cross-banded layers of veneer, or veneer and a core of either lumber or particle board, bonded with adhesive. These products can be used in contact with fresh water and soil. Also, these products may be used in waterfront structures if they do not come in contact with salt water or salt water splash.

Treatment Standard: AWWPA C2 - For soil or fresh water exposure (ground contact only)

Brands: Each piece shall be legibly and permanently branded, marked, or tagged by the producer. An exception can be made when bundled lumber is 1” X 4” or less in size, when lumber is less than 2” X 4” in size, or when lumber is 36” or less in length. In these cases, only the exterior faces must be marked.

<b>Brand Information</b>	<b>Code Ltrs</b>	<b>Example Interpretation</b>
Supplier’s Brand	ABCO	Company name or logo
Plant Designation and Year of Treatment	D-86	Location & date treated
Species of Timber and Preservative Treatment	SPSK	Southern Pine treated with CCA
Preservative Retention(s)	4	0.40 pcf (Per spec.)
Other	Dry	If specified dry



<b>Code</b>	<b>Acceptable Species</b>
SP	Southern Pine
DF	Coastal Douglas Fir
*GU	Gums
JP	Jack Pine
LP	Lodgepole Pine
*OA	Oaks
RW	Redwood
WH	Western Hemlock
WL	Western Larch
WP	Ponderosa Pine

Note: \*Hardwoods are not recommended for use with ACA, CCA, ACZA.

**Code                      Acceptable Preservatives (Check Specifications)**

C, TA, TB, TC,	Creosote (Code indicates types of creosote)
TD	
SB	Ammoniacal Copper Arsenate (ACA)
SK, SC, SJ	Chromated Copper Arsenate (CCA)(Types C,A,B)
SZ	Ammoniacal Copper Zinc Arsenate (ACZA)

Note: Creosote or pentachlorophenol treated products should not be used in any indoor structure or where there is possibility of contact with humans, animals, or food products.

Acceptable Quality Marks: AWPB Marks as indicated.

LP-22 - Treated with ACA, CCA, or ACZA to a minimum retention of 0.4 pcf.

LP-55 - Treated with creosote to a minimum retention of 10 pcf.

Sometimes the AWPB Mark will be combined with the Producer's information into one brand. The combined brand will include the following information:

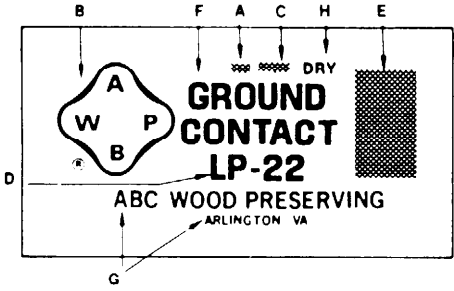

1989  
QUALITY  
SPID.  
CONTROL

GROUND  
CONTACT

1990  
AWPA  
C2, C9  
STDS

CCA-B .40  
ABC LUMBER CO.  
PENSACOLA, FLORIDA

- A Year of treatment
- B American Wood Preservers' Bureau trademark
- C The Preservative used for treatment
- D The applicable American Wood Preservers' Bureau quality standard
- E Trademark of the agency supervising the treating plant
- F Proper exposure conditions
- G Treating company and plant location
- H Dry or KDAT if applicable

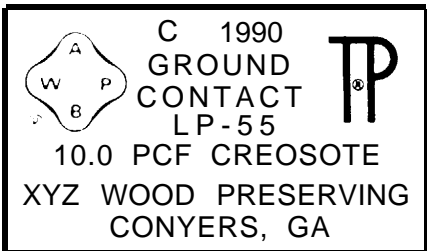

**TABLE 5: LUMBER, TIMBER, AND PLYWOOD  
FOR MARINE USE**

Lumber, timber, or plywood as in Table 4 that will be used in contact with salt water or salt water spray will be subject to attack by marine borers.

Treatment Standard: AWWA C2 - Material Subject to Marine Borer Exposure

Brands: Each piece shall be legibly and permanently branded, marked, or tagged. An exception can be made when bundled lumber is 1" X 4" or less in size, when lumber is less than 2" X 4" in size, or when lumber is 36" or less in length. In these cases, only the exterior faces must be marked.

<b>Brand Information</b>	<b>Code Ltrs</b>	<b>Example Interpretation</b>
Supplier's Brand	ABCO	Company name or logo
Plant Designation and Year of Treatment	D-86	Location & date treated
Species of Timber and Preservative Treatment	DFSK	Douglas Fir treated with ACA
Preservative Retention(s)	2.5	2.5 pcf (Per spec.)

<b>Code</b>	<b>Acceptable Species</b>
SP	Southern Pine
DF	Coastal Douglas Fir
*GU	Gums
JP	Jack Pine
LP	Lodgepole Pine
*OA	Oaks
RW	Redwood
WH	Western Hemlock
WL	Western Larch
WP	Ponderosa Pine

Note: \*Hardwoods are not recommended for use with ACA, CCA, ACZA.



**TABLE 6: POLES**

Poles are usually round and are partially embedded in the earth. Poles are to be used to support utility or distribution equipment.

Treatment Standard: REA Specification DT-5C which references AWPA C4

Brands: The producer shall brand each pole 10 feet from the butt end (larger end) if 50' or less in length, and 14 feet from the butt end if 55' or longer. Each brand shall show as a minimum:

<b>Brand Information</b>	<b>Code Ltrs</b>	<b>Example Interpretation</b>
Supplier's Brand	ABCO	Company name or logo
Quality Assurance Mark	WQC	
Plant Designation and Year of Treatment	D-86	Location & date treated
Species of Timber and Preservative Treatment and Retention	DFC-H	Douglas Fir treated with creosote H = Heavy, S = Standard
Class and Length	3-40	As per specification

<b>Code</b>	<b>Acceptable Species</b>
SP	Southern Pine
DF	Douglas Fir
EC	Northern white cedar
LP	Lodgepole Pine
NP	Red (Norway) Pine
WC	Western red cedar
WL	Western Larch
YC	Alaska yellow cedar

**Code                      Acceptable Preservatives (Check Specifications)**

C, TA, TB, TC, TD, CC	Creosote (Code indicates types of creosotes)
PC, PD, PA	Pentachlorophenol (in different solvents)
SB	Ammoniacal Copper Arsenate (ACA)
SK, SC, SJ	Chromated Copper Arsenate (CCA)(Types C,A,B)
SZ	Ammoniacal Copper Zinc Arsenate (ACZA)

Retention: Indicated as S = Standard or H = Heavy. The retention rate will vary for different species.

## TABLE 7: CROSSTIES AND SWITCH TIES

Crossties and switch ties are sawn rectangular timbers that will be used on or in the earth to support rails.

Treatment Standard: AWP A C6

Brands: The producer shall brand each tie at either end. Each brand shall show as a minimum:

<b>Brand Information</b>	<b>Code Ltrs</b>	<b>Example Interpretation</b>
Supplier's Brand	ABCO	Company name or logo
Preservative	C	Creosote
Year of Treatment	D-86	Year treated

Acceptable Species: Unless otherwise specified in the contract, all ties shall be either White or Red Oaks or dense Southern Pine. Pine will be considered to be dense if at least one end averages 6 rings per inch on a radial line three inches long. Other species that may be used, if allowed in the contract specification, are Ash, Beech, Coastal Douglas fir, Gum (black and red), Hemlock (western), Hickory, Locust (Black and Honey), Maple, dense Pine (Jack, Lodgepole, Ponderosa, Red), Walnut, and mixed hardwoods.

Acceptable Preservatives: Creosote, Pentachlorophenol

Penetration and Retention Rates: These will vary according to species. AWP A C6 states minimum standards for each.

Incising: Douglas-fir and all hardwood species will be incised prior to treatment.

Acceptable Quality Marks: None Available.

Note: The producer's brand will not include the species nor the preservative retention rate. These can be found in the inspection report that accompanied the shipment. You should verify that the information in the report conforms with the specification and the AWP A standard. You should also check for evidence of borings which should have been done to determine penetration and possibly retention.

**APPENDIX D**  
**WOOD PRODUCTS INSPECTION SCOPE OF WORK**

INTRODUCTION

1.1 SCOPE

The Contractor shall provide on-site inspection, sampling and evaluation of all specified wood products, both treated and/or untreated, at the producer's facility or in inventory at the buyer's facility for conformance to the specifications of the U. S. Naval procurement and purchase order(s).

2.0 APPLICABLE DOCUMENTS [list industry or Association standards]

Federal Specifications

Military Specifications

NAVFAC Specifications

Association Grading Rules:

[NELMA, NH&PMA, SPIB, WCLIB, etc.]

Treatment Standards: [AWPA, AWPB, TT-W-00571J]

Testing Standards: [ASTM, ANSI]

Quality Control and Inspection Procedures (AWPB)

Others as appropriate

3.0 PERFORMANCE REQUIREMENTS

3.1 GENERAL

3.1.1 The Contractor shall provide all services, personnel, and equipment as required to complete the inspection and sampling work at U.S. Naval Installation or other site named.

3.1.2 The Contractor shall provide all laboratory facilities and personnel required for analysis and testing the following:

- a. Species determination
- b. Preservative: penetration and retention



## 3.2 SPECIFICATION REQUIREMENTS

3.2.1 Wood products to be inspected shall meet the following specifications:

- a. Product: (specify) Lumber, Timber, Piling, Poles, Posts, Railroad ties, etc.
- b. Product Species: [specify]
- c. Product Grade: [Indicate "Association Grading Rules" and Grade]
- d. Preservative Treatment: [Creosote, Waterborne Arsenical salts, etc.]
- e. Preservative Treatment Standard: [Specify AWPA C- \_\_\_\_]
- f. Brands or Marks: [Indicate marks required and location]
- g. Other:

3.2.2 Schedule. This contract will commence on/or about [Date] and [Select one] shall conclude with the submission of final reports by [Date], or shall remain in force until terminated in writing by either party at least 60 days prior notice.

## 3.3 REPORTS

3.3.1 The Contractor shall submit the following reports:

- a. Written report of findings (each occurrence or final)
- b. Laboratory reports (each occurrence or final)
- c. Photographs (as required)
- d. Invoice (each occurrence, monthly or final)
- e. Others (as required)

## APPENDIX E BORING SAMPLE REPORT

Installation: \_\_\_\_\_

Address: \_\_\_\_\_

Sampled By: \_\_\_\_\_ Date: \_\_\_\_\_

**Standard**

AWPA \_\_\_\_\_

Preservative \_\_\_\_\_

Retention \_\_\_\_\_

**Species**

Douglas Fir \_\_\_\_\_

Hemfir \_\_\_\_\_

So Pine \_\_\_\_\_

Ponderosa \_\_\_\_\_

Other \_\_\_\_\_

**Material, Size & Tally**

Lumber \_\_\_\_\_

Plywood \_\_\_\_\_

Piling (# of pcs) \_\_\_\_\_

**Creosote & Penta Only**

Charge No. \_\_\_\_\_

No. of Borings \_\_\_\_\_

DIA \_\_\_\_\_ LEN \_\_\_\_\_

**Marking**

Yes

No

Grade Mark \_\_\_\_\_

Quality Mark \_\_\_\_\_

Other Marks \_\_\_\_\_

Grade Mark: \_\_\_\_\_

Remarks: \_\_\_\_\_

> Spwd.	> Pene.	> Pene. >	> Spwd.	> Pene.	> Pene. >
> Depth	> In	> % >	> Depth	> In	> % >
1 > _____	> _____	> _____ >	11 > _____	> _____	> _____ >
2 > _____	> _____	> _____ >	12 > _____	> _____	> _____ >
3 > _____	> _____	> _____ >	13 > _____	> _____	> _____ >
4 > _____	> _____	> _____ >	13 > _____	> _____	> _____ >
5 > _____	> _____	> _____ >	15 > _____	> _____	> _____ >
6 > _____	> _____	> _____ >	16 > _____	> _____	> _____ >
7 > _____	> _____	> _____ >	17 > _____	> _____	> _____ >
8 > _____	> _____	> _____ >	18 > _____	> _____	> _____ >
9 > _____	> _____	> _____ >	19 > _____	> _____	> _____ >
10 > _____	> _____	> _____ >	20 > _____	> _____	> _____ >

Note: Each piling must be bored.

<b>To Be Completed By Laboratory</b>		
Sample No. _____		
<b>Retention</b>	%	pcf
Chromium (CrO <sub>3</sub> )	_____	_____
Copper (CuO)	_____	_____
Arsenic (AS <sub>2</sub> O <sub>3</sub> )	_____	_____
Zinc (ZnO)	_____	_____
Total	_____	_____
	Penta/Creosote	_____
Conforming _____ Nonconforming _____		
Laboratory: _____		
Address: _____		
Signature & Date: _____		