

M2

Metric Design Guide

**General Services Administration
Design and Construction Division
Region 3 Philadelphia**

Third Edition

October 1993

Design

Introduction	1
Philosophy	3
Usage	6
Drawings	7
Specifications	
Rounding	8
Codes and Standards	9
Arch / Block	10
Arch / Brick	
Arch / Carpet	
Arch / Ceiling Systems	
Arch / Doors	
Arch / Drywall	11
Arch / Elevators	
Arch / Glass	
Arch / Landscaping	
Arch / Lighting Fixtures	
Arch / Lumber	
Arch / Plywood	
Arch / Renovation	12
Arch / Roofing	
Arch / Sheet Metal	13
Arch / Slope	
Arch / Stone	
Arch / Studs	
Arch / Woodwork	
Civ / Concrete	14
Civ / Concrete Pipe	
Civ / Geotech	
Civ / GIS	15
Civ / Infrastructure	
Civ / Reinforcement	
Civ / Roads	16
Civ / Sitework	
Civ / Surveying	
Electrical	17
Environmental	
Estimating	
Mechanical / General Fasteners	18
Mechanical / Anchor Bolts	
Mechanical / Fastener Data	19
Mechanical / HVAC	21
Structural	22

General

Preparation	23
Design Policy	
AE / CM Advertisements	24
Construction Advertisements	
AE / CM Scope Guidance	
Submittals	25

Products

01 Tools	27
03 Rebar	
04 Block / CMU	28
04 Block / Glass	
05 Anchor Bolts	29
05 Nuts	
05 Steel Plate	30
05 Structural Bolts	31
06 Lumber	32
06 Plywood	
07 Curtainwalls	
07 Insulation	
08 Doors / Metal	33
08 Doors / Wood	
08 Windows	34
09 Carpet	
09 Ceiling Systems	
09 Drywall	
09 Floor Tile	
10 Access Floor	35
14 Elevators	
15 Grilles and Diffusers	
15 Mechanical Equipment	36
16 Conductors	
16 Lighting Fixtures	37

Drawings

Arch / Cabinets	39
Arch / Door	40
Arch / Door Jamb	41
Arch / Garage Detail	42
Arch / Garage Elevation	43
Arch / Guardrail	
Arch / Landscape Plan	44
Arch / Landscape Section	45
Arch / Lintel	
Arch / Lobby Renovation	46/47
Arch / Reflected Ceiling	48
Arch / Renovation Plan	49
Arch / Restroom Elevation	50
Arch / Restroom Plan	51/52
Arch / Security Desk	53
Arch / Stair Detail	54
Arch / Stair Section / New Const	55
Arch / Stair Section / Renovation	56
Arch / Storefront Detail	57
Arch / Wall Section	57/59
Arch / Window	60
Civil / Harbor Detail	61
Civil / Harbor Plan	62
Mech / Air Distribution	63/64
Scientific / Site Plan	65
Scientific / Sketches	66
Struct / Base Plate	67
Struct / Foundation Wall	68/69
Struct / Grade Beam	70
Struct / Reinforcement	70
Struct / Welds	71

Road Design Data

Road Design / Colorado	
. Plans, Stations, Cross Sections	72
. Proposed Features on Plans	73
Road Design / GSA	
. Site Plan	74
. State Roadway Plans	75/76
. State Roadway Profiles	77
. Cross Sections, Pavement Details	78
. Curb and Gutter Details	79
Road Design / Illinois	
. General, Drafting, Surveying	80
. CADD Issues	82
. Land Acquisitn, Geometric Design	83
Road Design / Indiana	
. Sheet Size and Format	84
. Stations, Cross Sections	84
. Angles and Horizontal Curves	85
. Elevations, Contour Intervals	86
. Plot Accuracy, Proposed Features	
. Cross Section Elements	87
. Plan and Profile Sheets	88/90
Road Design / Kentucky	
. Sample Geometric Design Criteria	91
Road Design / Louisiana	
. Design, Software, Steel	92
. Bolts, Rebar, Scales	93
. Curve Set, Prestressed Girders	94
. Future Projects, Priorities	95
Road Design / North Carolina	
. Stations, Intervals, Plan Sheets	96
. Photogrammetry, Map Labelling	97
. Existing Features, R/W	98
. Att 2 Plan Sheet Guidelines	99
. Att 3 Planimetric, Topo Maps	100
. Att 4 Existing Map Features	101
Road Design / Ohio	
. Sample Reconstructed Bridge Data	102
Road Design / Virginia	
. Plan Guidelines	103/4
. Pavement Detail, Road Section	105

Acknowledgements	106
-------------------------	-----

Introduction

Since issuance of the last version of this guide, SI has taken firm root in the US construction community.

For almost all Americans, there is now a project being planned or designed which will be built in metric within 1-2 hours of their home.

Many of us are located close to some of the projects already being constructed in metric.

Some of the largest federal and state projects are now being planned or designed in metric, and significant activities have begun at local levels.

It is highly probable that the type of project you are starting has already been designed in metric by another region, or another federal, state or local government.

At a minimum, something similar has been designed in metric, to answer your questions. The trick is locating the proper source, and obtaining material you need.

Through strong communication this can be achieved.

Now managing major metric construction projects, we reject assertions that metric design and construction are not feasible.

After January 1994, all GSA renovation and new construction projects shall be designed in metric.

We thank the private firms, contractors, government agencies, and individuals who provided feedback.

This document may be freely copied and distributed.

Our goals for this edition have been:

1. Give lessons learned on use of metric.
2. Minimize impact on design firms, contractors, and producers, while complying with the national directive of complete metric conversion.
3. Use private sector guidance wherever possible.
4. Convert to a metric thought process.

Many regions have metric construction, and most others have done metric planning or designing, so basic material has been condensed or deleted.

We have avoided using old units wherever possible.

5. Improve page efficiency, getting more on fewer pages, making it feasible to insert the document into every AE and construction bid package.

This also reduces costs and conserves resources.

Most guidance is consistent with the previous edition.

This document supplements national policies. If it conflicts with them, those documents of course govern.

WARNING Sample drawings and data are from many sources and are for the explicit purpose of showing good metric practice. They are not represented as current design criteria. Applicable codes and criteria should be consulted prior to design on projects.

Sample drawings are from US projects in design and construction, so drawings may be preliminary. Some drawings are from project add alternates, thus actual construction may vary from details shown.

We admit selecting only details or portions of details showing good metric practice. Some details have been modified to delete inconsistent practice. Due to graphic modification, details may not be to scale indicated.

Based on project knowledge, we feel confident to design and build any road, sitework, or facilities project in metric, anywhere on American soil, at little to no cost impact, using the compromise approach established in this document.

As is unfair to project that the information in this document is of our doing only. We have tried to credit other sources for their metric experience.

As our leaders in the recent past simply resolved to place an American on the moon, and attained this through the sheer willpower and resolve of the American people, let us simply resolve to conclude the issue of metric conversion, for the national good.

Let us make the firm choices and gladly accept the effort required. We are looking for partners to move boldly and decisively with us in a direction that is very clear at this point.

Doing this will level the playing field for the next generation, the children and grandchildren in our families, so they may compete head on with other nations, without hindrance of an outdated system whose time has come.

In this edition, we have focused primarily on hard metric products commonly used in construction.

For a listing of firms that can fabricate or install these products, ie, construction firms that feel comfortable working in metric, see M1.

Products listed are made in USA, unless noted.

This directory is open to firms making metric products commonly used in federal construction.

Firms interested in being included may contact us.

Some firms listed minimum orders for products. These minimums will get smaller as we constantly buy metric products. If your order is half the minimum listed or more, we recommend you contact the manufacturer to determine their current interest.

We have deleted some product categories where obtaining metric products has not been a problem, and have given overall guidance to assist specifiers.

America recently regained its status as the world's largest exporter, and our firms are improving market share for many products.

Momentum is building in the American industrial machine, and an important component is use of SI.

Over the past year, we have spoken with thousands of manufacturers, designers, project managers, personnel in education, and representatives of construction firms.

The mood of the nation has shifted. There is a significant and growing body of people that realize that metric is a smart move for this country, and these individuals support the movement toward this system. There is ofcourse resistance.

The American construction community specifically though has responded to the challenge. We now track which contractors have done metric construction, which can build in metric with little difficulty, and which firms have already bid metric projects in this country. These results will appear regularly in M1.

While metric receives mixed initial review, many tradespeople prefer it after some learning period.

We have also encountered metric capability where we did not expect it.

We must conclude that original estimates of extensive effort to convert did not materialize.

When partnering between government and private industry is meaningfully applied, conversion to metric, and realization of the benefits of this system, are no more difficult than the introduction of any new technology or policy.

As the Federal landlord, we have frequent contact with many federal, state and municipal agencies.

Another document, M1, was developed to keep abreast of their metric conversion activities.

Title: M1, Metric Activity in US Construction

M1 is separate because metric projects and activities within government are changing rapidly, needing more frequent revision than design information.

M1 will be updated every few months.

M1 can be downloaded by interested parties from the Region 3 Bulletin Board Service: 215 656 6465

All regional specifications will soon be upgraded to conform to this document.

We welcome comments on this text.

Otto Schick Tel 215 656 5822 Fax 215 656 5822

GSA
100 Penn Square East, Room 610
Philadelphia PA 19107

Philosophy

These three pages give our ideas on successful conversion while minimizing any costs involved.

There are 5 priority actions, ranked by importance:

1. M60
2. Strong Communication
3. Professional Rounding
4. Metric Codes and Criteria
5. Partnering with the Construction Community

1. M60

M60 is the most important action necessary for metric conversion, and takes the most courage to implement.

In many documents read, we have not seen a simple definition of success, of when an agency is metric.

This formula mirrors our progress.

M60 means "metric on 60 % of design this year".

With 60 % of design in the current fiscal year being done in metric, we feel all necessary momentum will be generated to permanently sustain conversion.

Example: A certain region, in this fiscal year, has 300 design projects, total of about \$ 100 million.

If 60 %, or \$ 60 million, is designed in metric, the entire organization will move to metric, and rapid development of group confidence takes place.

We select design as we view it as a largely irreversible process, without significant cost after a certain point. 60 was used since it represents a majority of the work.

The implications of this statement are significant.

Fewer projects can be selected as metric projects

As few as 10 or 20 projects could combine from the design program can meet this M60 threshold. Then it is possible to work with a small group of architects or engineers who will run comparatively few projects, yet this engine will convert the entire organization. These people should generally be willing to work in metric.

We recommend that the M60 program be made up of medium to large size projects, the larger the better.

Anchor Effect This 60% block formed an anchor for our conversion effort. With many major projects being

designed metric, a galvanizing effect occurred to managers of small and medium sized jobs. They felt more confident to do metric projects, with x or y project going well in metric.

Combined Buying Power With major projects being done in metric, local suppliers are more willing to make changes to supply metric products. Some suppliers were reluctant to go metric without indication it would be worth it. With M60, this project block is often enough to show a sustained market.

This block can establish metric product availability, and lower order quantities. Ex, if a medium project needs 200 pieces of metric product x, some firms may not supply it. However, with 200 now, and another 4000 documented through M60 over a few years, views may change considerably.

To gain this same amount of buying power, an organization may have to select perhaps 50 or 100 projects of smaller construction value, by far the more difficult route to becoming a metric organization.

On The Job Training M60 can make the organization metric as it brings the best metric training to the organization at about no cost. While only ten or fifteen staff run metric projects, we found many other people and divisions involved at stages (ex, reviewing designs or estimates, or in technical meetings). This framework introduces others to metric. Drawings, specs, estimates, appear in near finished format, developed by familiar faces, which enhances confidence.

A pool of metric experts is formed, the knowledge base grows quickly, and guides the organization.

Automatic Infrastructure When an group as ours simply decided to be metric, to meet M60, automatic needs were created for specs, criteria, codes, training devices, and other parts of metric infrastructure. Priorities are soon established. (ex, What specs to convert? This answered by seeing the 120 or 150 needed by the M60 program) A program becomes prepared for 100 % metric design. Items not needed by an M60 program may never have to be converted.

Partial Conversion Some will not wish to be a part of conversion. M60 allows projects to be developed in old units, for an interim period, if truly necessary.

In summary, we feel an organization can go metric almost surgically, highly successfully, by deciding to be metric, and meeting M60 in this fiscal year.

Related groups move after M60 action occurs. Design and construction firms trained workers. Builders and unions sought assistance. Suppliers made changes, and developed product literature.

In short, once an organization decides to be metric, all other activities fall into place.

Deciding to be a metric organization, ie M60, is by far the most important activity in metric conversion.

This applies not only to government, but also to private and educational organizations.

Ex, Moving a college building program to M60 status would have more impact than courses in metric architecture alone. M60 creates a laboratory on campus, actual uses of SI. Many educators say if industry used SI, english would vanish from schools.

Rulers and posters create awareness, but M60 will move construction decisively to the SI system.

2. Strong Communication

During much training, a major lesson learned, predictably, is that people feel much more confident to work in metric, when they know other projects nearby are being done in metric.

It makes a great difference to know in the next county, a \$ 15 million building, or a \$ 10 million interchange, is in design or construction in metric.

Most people know metric is here, but it galvanizes reality when projects, and exact locations, are known.

As metric coordinator, after starting the M60 program, the important task is letting those in and outside the region know the metric projects.

This can involve as little as a one page list, or a message on e-mail, as to what projects are being done.

The National Institute of Building Sciences (NIBS), Construction Metrication Council, manages conversion of US construction, involving agencies, producers, builders, and professional groups. The Task Force on Metric Projects is ideal to communicate your activities. You can improve confidence of those around you to go metric by relaying your activity. New projects by nearby groups then enhance your ability to obtain metric products and may lower costs or minimum orders.

We recommend a 1-2 page Metric Project List, giving:

All metric projects being done in your organization or region, construction value of each, and the status (planning, survey, design, construction)

This is the most powerful information you can have at your disposal as a metric coordinator.

We would give this to staff and the Task Force. If interested, please fax to either task force co-chair:

Otto Schick Fax 215 656 5836 Tel 215 656 5822
Joe Sacco Fax 703 693 6934 Tel 703 614 4879

3. Professional Rounding

Over 90 % of products in construction today will not physically change during metric transition. We simply show dimensions in metric, ie, soft conversion.

These two terms help explain how to use 90 % soft metric products and still use round dimensions on projects. Examples from varied areas follow.

Product Dimension: size of an item not easily modified

Design Dimensions (dds): dimension that can be varied, often through fabrication or installation

Airports Concrete and soil have no dimension. Structures of them are often governed by dds. Width of runways and taxiways and dimensions of clear zones, can often be hard metric. Imaginary surfaces may also be dds, if the airport is frontal layout, finger system, split finger, or other variety. Product dimensions for lighted runway and taxiway lights, beacons, wind indicators, guidance signs and gangplanks, can often be soft converted.

Bridges Rolled steel wide flanges to construct simple steel bridges are soft converted products, yet beam, girder, and lateral bracing lengths are dds which can be varied. Vertical bridge clearances are dds.

Environmental In water supply and waste treatment, components (ex, clarifiers or centrifuges) could be soft converted, yet structures for sedimentation tanks, grit chambers, sand filters, activated sludge process facilities, oxidation ponds, sludge thickening facilities involve many dimensions which can be rounded.

Facilities Rooms are often from centerline to centerline or face to face, if studs are hard or soft metric. Light switches are soft, but mounting heights are easily

rounded. Ceiling heights are dds. Bar placements and wall thickness are dds. Slab to slab heights (ex, 5 m) are dds.

Conduit, alarm systems, motors, receptacles, switchgear, air handlers, boilers, pumps and valves will have product dimensions soft converted, but installation dimensions (ie, dds) are hard converted.

Marine Mooring posts, cleats, piles, fender systems, buoys, and precast breakwater units have product dimensions which could be soft converted. Yet turning basins, breakwaters, freight terminals, bulkhead wharfs, dolphins, fixed mooring berths, rock moles and trestles, have dimensions that are readily rounded.

Rail 136 RE rail and standard joint and tie components may be used in elevated high speed rail, with products soft converted, yet center to center for support piers could be hard, such as 25 m. Top and subballast thickness are dds, as well as right of way, such as 20 m each side. Frogs, spikes, and wood ties could probably be soft converted.

Water Engineering Prefabricated components in hydroelectric facilities may be soft converted, such as impulse or reaction turbines. Yet a primary product is concrete, so the dds such as height, thickness, spillway and intake tower dimensions, could be hard metric.

100 % Rule Over 90 % of current products will be used, but strive for 100 % hard design dimensions.

Most drawings show installation dimensions, which can be varied, often independent of product sizes. Thus drawings will be mostly hard metric and make installation by our partners in the trades easier.

4. Metric Codes and Criteria

Criteria We recommend new or revised criteria for design (ex, handbooks, specs) be issued in metric only.

People no longer debate if or when, but realization of permanence emerges, and metric thinking begins.

Directives to go metric, along with issuance of dual dimensioned criteria, appear contradictory.

If the new ceiling height is 2700 mm, those with any experience will not forget this is about 9 feet.

Old documents propagate for years, even decades, and will bridge the gap from metric to english as needed.

Codes Grade A metric codes would make metric design

simpler and more desirable.

Ex, a code might state 44" (1118 mm) minimum width. While it is very helpful to have metric included, rounded design might lead to 1200 or 1150 being used.

The greatest improvement would be new dimensions in 100 and 50 mm sizes. Could 1100 be the new size? This is ofcourse a professional judgement.

However, since rounded metric sizes are not in codes yet, many still use english sizes during daily speech. Grade A codes would greatly assist metric transition.

Fortunately, many code sizes are lengths, which when converted usually get smaller, and offer many little cost savings. Ex, from above, if 1100 is possible, small savings would appear over many situations.

5. Partnering with the Construction Community

Construction firms have little time to prepare bids for a project. This pressure increases on a metric project.

Prepare your community with: 1) Reference Material 2) Clarity on Hard Metric 3) Advance Notice

Reference material reveals what you obtained from months of metric design. This document may be a good first step. List other suppliers you have found.

At pre-bid meetings, identify the hard metric products. Explain most products are the same as previously used.

Advance notice means alerting local groups, unions and societies of forthcoming metric projects.

In summary, from our experience with metric, we feel we could design and build about any project in this country, completely in the metric system, using this compromise philosophy.

From discussions with builders nationwide and talks with managers on metric projects, we could provide 10 firms to bid any metric project over \$ 500,000, almost anywhere in the United States.

January 1994 is feasible for all construction in our country to be designed in metric, utilizing techniques established in this document.

The design and construction projects now being done in metric indicate to us this is possible.

Usage

Metric Slang From PCs, CAD and fax, from Seatac to the Keys, the Alcan, the Lone Star, the Bay Area, and the Beltway, slang is part of our vibrant culture.

Americans are efficient and we like things fast. Our people will brand the SI system with our personality and make it our own.

While perhaps controversial, we do not discourage this, as we feel a verbally modified system will be more quickly accepted in society at large.

Smooth and catchy words such as nada are easily incorporated into our daily speech.

The critical issue is that SI be implemented, and that everyone is clear what the new expressions mean.

Few are confused when five kilos, a non-SI term, instead of five kilograms, are referred to.

This information shows techniques from daily usage, but is not represented as preferred metric practice.

mmoc We have seen the term "mmoc" on drawings, to mean mm on center. (ex, Fasten every 600 mmoc)

The "x" can verbally represent "hundred millimeters".

(ex, "five x", vs "five hun-dred mill-i-met-ers", 2 vs 7 syllables) This can be very efficient for lengths up to 10 meters (ex, 5 x, 12 x, 52 x, 78 x).

Even fractions can be verbally faster using x.
(Ex, point five x, vs. fif-ty mill-i-met-ers)

This also helps people to use 100 mm increments.

"x" does not conflict with any other SI symbols.

Modular Products such as ceiling tiles, access floor, light fixtures, and carpet tiles, have few standard sizes. We often use shorted names for 100 mm increments. 5 x 5 is 500 x 500, 6 x 6 is 600 x 600, etc.

Centimeters While not used in drawings and specs, they are used in other countries in day to day life. We sometimes call them "c's" (pronounced "seas"). (ex, the report was about 2 seas thick)
This technique was used earlier with cc's for volume.

Pascals "k-p-a" is often said instead of kilopascals, and "m-p-a" instead of megapascals.

Mass Megagram (Mg), equal to 1000 kg, is SI, and is our choice for large masses. (ex, rebar, steel, gravel)

We like to call them "meg". (ex, eighty meg of rebar)

This is already used by people in daily speech, such as a 25 meg hard drive.

We hear metric ton used, but we find it slow, and it can be confusing, since people often drop metric and say only tons, even when metric tons are meant.

Micrometers are often shown as "um" since the micro character can be hard to use on many keyboards. (ex, 25 um means 25 micrometers)

Superscripts can be cumbersome, and are often avoided in correspondence, using only the number.

2500 m³ means 2500 cubic meters.

1100 g/m² means 1100 grams per square meter.

Rule of 3's For Meters Many say, no matter how many classes attended, they will never have a feel for meters. The rule of 3's can help, and is fairly accurate.

Feet times three, move decimal left one digit.

50 feet, times 3 = 150, move decimal, 15 m

20 feet x 3 = 60, yields 6 m

Rule of 4's For Hectares This rule can help develop a general feel for converting commonly used acres to hectares (ha), or hecters, as many pronounce it.

Multiply acres times 4, move decimal left one digit.

30 acres x 4 = 120. Move decimal yields 12 hectares.

10 acres x 4 = 40, yields 4 ha.

Rule of 10's For Square Meters

Square Feet divided by 10 = Square Meters

500,000 SF divided by 10 = 50,000 m²

For diehard fans of the old system, who can not bring themselves to use meters, the ideal transition unit may be the metric foot, equal to 300 mm, or 0.3 m.

So the 8 foot ditch becomes 8 metric feet, or 2.4 m.

Drawings

Good drawing practice is demonstrated on the sample drawings in this document.

Centimeters shall not be used.

Dual dimensions shall not be used.

Example, 200 mm (7-7/8")

Dual dimensions are a complete waste of time in construction documents. When english units are there, readers use them and ignore the metric.

Use preferred scales:

1:1 1:2 1:5 1:10 1:20 1:50 1:100 1:200 1:500 1:1000

Many state DOTs use 1:250 for urban plan sheets.

ISO Paper Sizes are the standard international paper sizes, and are often available within a few weeks, anywhere in our country, from domestic sources.

Many state and federal agencies, such as Army Corps, Huntsville Division, are now using them.

We are now generating designs in this region around A1 size. Designs are to now use ISO sizes, see below.

The Government Printing Office now stocks A4 paper for purchase by other agencies.

Many state highway groups have adopted A1 as their standard drawing size.

A0	1189 x 841	A3	420 x 297
A1	841 x 594	A4	210 x 297
A2	594 x 420		

Specifications

Several questioned our use of mm for large dimensions. In response, we have utilized both m and mm in specifications in the interim period, and have found little difficulty or confusion using either.

Our new general rule is to use m or mm, whichever you prefer. Examples:

Concrete to be 200 mm thick. (0.2 m could be used)

Clearance shall be 1500 mm. (1.5 m could be used)

This practice differs from drawing usage where mm are used exclusively in many areas.

In specifications, the unit (ex, m or mm) is almost always present. Little room exists for confusion. On drawings, using mm eliminates the need to write m or mm, and eliminates decimal usage for all but large scale civil and road design drawings.

Centimeters should not be used. A small class of items reference standards using cm or cm², such as fire ratings for some products. These areas only, which account for less than 2 % of specification references, should make reference to cm or cm².

It is recommended that each region establish a directory of pure SI specifications, as we have done, and not mix SI and english specifications.

It is also not recommended to have both metric and english in a guide specification section, as this requires spec writers to edit english out of the document.

Nominal Technique Many spec references can effectively use nominal mass, nominal volume, or nominal length technique. Ex, if 1 gallon of product x is required (or, 3.785 L) the spec could be rewritten using nominal volume, requiring 4 L (+/- 0.25 L). People can then say 4 L when referencing this item, yet still allow current product to be submitted.

Rounding

Having seen many metric drawings, and seeing the downstream effect, we feel rounding of design dimensions is a very high priority.

Too many review comments on metric projects state that we do not prefer bar spacings at 305 mm on center, or base plate dimensions of 460 x 460, and similar items.

The professional rounding concept helped, but we have developed a simpler, but firmer stance on this issue.

The Ratchet: 100 50 10 5 1

The ratchet is a five level priority system, 100 being highest priority, which requires justification to move down one ratchet. (ex, to move from 100 to 50)

Thus design dimensions, created in ones mind, should be increments of 100 mm, unless solid reasons exist to move down a ratchet to design in 50 mm increments.

Room sizes in new construction and renovation are ofcourse in 600 mm increments unless not possible.

The ratchet applies most directly to design dimensions, which are smaller than room dimensions, such as 3600 x 4800, but larger than product dimensions, such as 92 mm metal stud sizes, which are often fixed.

Examples: bathroom stall widths, bathroom component mounting heights, concrete wall thickness, window dimensions, base plate sizes, parking stall widths, cabinet widths, counter heights, slab thickness, door louver and window sizes, ductwork sizes, shelf spacing, railing heights and on center dimensions, landscape installation dimensions, etc.

Critics have indicated this is not always possible, which we know. But increments of 100 and 50 mm should now become the baseline for project design, with 10 and 5 mm increments used only as required.

Simple Mathematical Rounding shall not be used.

Ex, A design dimension simply converted to 3658 mm.

Professional Rounding shown below, takes simple mathematical rounding, adds professional judgment.

Step 1. Convert The Dimension Mathematically

A pavement width in some codes becomes 914 mm.

Step 2. Select A Replacement Dimension (Use Ratchet)

1000 would be the preferred replacement.

950 would be used only with justification.

900 would offend the code and could not be used.

For non code dimensions, smaller dimensions in increments of 100 might be selected.

Ex, custom cabinets are to be built to a width that converts to 508 mm. 500 would be the probable choice, and would be permitted if this were not a code or exact required dimension.

Codes and Standards

About 90 % of codes and standards needed by us to do design are available today in metric.

Many not in metric are being converted now.

Codes and standards have not hindered renovation or new construction designs in metric to date.

Documents listed below are now being extensively used in metric design projects of every sort.

For codes or standards not in metric, rounding techniques have been proven sufficient.

The missing component to full metric conversion in United States construction is the implementation of metric design projects in the federal, state, local and private design communities.

Only this full implementation will create the need to continually improve metric codes and standards.

These are sample documents where most of the text, or the entire text, contain SI/english or pure SI data.

AASHTO Standard Specs. for Structural Supports for Highway Signs, Luminaires, and Traffic Signals (1985), including revisions to 1991, have SI data.

Construction Manual for Highway Bridges and Incidental Structures has SI in many areas.

Standard Specs for Highway Bridges contain SI data and formulas in appendix E.

Standard Specs for Transportation Materials, now contain SI, in Parts 1 and 2. Many tests use SI only. Many standards are identical to ASTM standards, most of which now contain SI data.

ACI 318M, 318.1M available, which are SI versions.

ACSM Amer Congress on Surveying and Mapping Metric Practice Guide was recently reissued.

AFPA Amer Forest and Paper Assn First LRFD manual and next National Design Spec will have SI.

AIA Graphic Standards, has SI chapter. Masterspec will be available in metric shortly.

AISC LRFD Spec and Properties of Structural Shapes are in SI version. Metric Database for ASD and LRFD available. Manual of Steel Constr to be SI in 1994.

ASHRAE All handbooks available in SI.

ASME Most ASME standards contain SI data.

ASTM ASTM Standards in Building Codes contain SI in almost every standard.

AWS AWS standards contain SI data.

BOCA National Building, Fire Prevention, Mechanical and Plumbing Codes have SI.

CSI CSI Spectext has SI. Other CSI publications contain SI or are being converted now.

CCSB Cedar Shake and Shingle Bureau WA, New Roof Construction manual comes in SI version.
Michael Westfall 206 453 1323

IES Illumination Engineering Society Handbooks contain SI data.

KCMA Kitchen Cabinet Mfrs Assn A161.1, Recommended Performance and Construction Standards for Kitchen and Vanity Cabinets now has SI. KCMA reports exporting firms do so in SI units.

NEBB National Environmental Balancing Board Fundamentals, Air Systems, and Hydronic Systems guides available in SI.

NFPA Almost all standards now have SI. Examples:

NFPA 13 Installation of Sprinkler Systems
NFPA 20 Installation of Centrifugal Fire Pumps
NFPA 24 Private Fire Service Mains
NFPA 70 National Electric Code
NFPA 101 Life Safety Code

SBC Standard Building Code has SI. 1994 versions of Fire, Plumbing and Mechanical will have SI.

SMACNA All SMACNA publications now being converted to contain SI data.

UBC 1994 versions of Building, Fire, Mechanical, and Plumbing will have SI.

UL Many UL standards contain SI units.

Architectural / Block

Hard metric block has 12.5 block per m².

Metric block has been installed on US projects.

Standard mortar joint for brick and block is 10 mm.

Sizes: 90, 140, 190 thick, 190 x 390 face

Some metric block are being supplied using molds borrowed from sources that already owned them, eliminating mold purchase costs.

See other national policy on this issue.

Architectural / Brick

75 modular metric per m², 50 metric jumbo per m².

BIA says most member firms can supply metric brick. Metric brick has been used on US projects.

Metric modular is most common: 90 x 57 x 190
Jumbo brick is also popular: 90 x 90 x 190

Three modular courses with 10 mm joints rounds to 200 mm. Two jumbo courses equals 200.

Brick should be specified in metric whether ASTM C216 or ASTM C62 / AASHTO M114 is used.

Weepholes mostly spaced in 100 mm sizes. (ex, 600)

Architectural / Carpet

Most firms have the dies and can or do make metric tile. It is usually not stocked. Minimum orders go from no minimum to several hundred square meters. Most said as industry goes metric, minimums would drop and premiums would shrink or be eliminated.

Most common sizes are 500 x 500 and 600 x 600.

Our projects are now specifying hard metric tile sizes.

Architectural / Ceiling Systems

Many design and construction projects, both renovation and new construction, are using the 600 x 600 system.

Many facilities with 2 x 2 grids are not adversely affected by use of new 600 x 600 grids, since coordination between grids, window mullions, and other architectural elements is often not maintained through years of renovation.

With hard metric ceilings, room dimensions can be multiples of 600 mm, giving clean, rounded dimensions to construction personnel for layout.

Architectural / Doors

A popular size is 900 x 2100, especially in interior partitions. 1000 x 2100 is sometimes being used.

Public Works Canada often uses 950 x 2150, with a 50 mm frame, matching 2200 block coursing.

Based on project feedback, and ease of obtaining hard metric sizes, all of our projects are now using hard metric door and frame sizes.

Louvers and glass should be in hard metric dimensions, such as 300 x 300, 450 x 450, etc.

Thickness Most architects soft convert door thickness and are using nominal 45 mm as standard.

Frames Almost all door frame section dimensions are being rounded to the nearest 1 mm. (ex, 13, 25, 41, 50, 80 mm) Lengths and widths match hard metric door sizes and should be hard metric. (ex, 900 x 2100)

Architectural / Drywall

Sheet width is 1200. Standard stud spacing is 400.

Thicknesses are the same to minimize production impact. Most architects show these as 13 and 16 mm on drawings, instead of the exact 12.7 and 15.9 mm.

Minimum orders vary by firm. Partial truckload orders are available, but most firms indicated one truckload as a minimum order. We have now approved metric drywall submittals and will soon begin installation.

We feel many projects using 500-2000 m² should be able to feasibly obtain it. The range of 2000 m² or more should have no difficulty.

Architectural / Elevators

We propose capacities be specified to the next lowest 50 kg. (ex, 4000 lb = 1816 kg. Specify as 1800 kg)

Signage in the elevator would show 1800 kg only.

Most mfrs can make hard metric platforms. We feel it is not critical, and recommend allowing standard sizes. Specifying 50 mm platform sizes is preferred, but allow standard english platform sizes to be submitted.

(ex, 5'7 x 7' platform = 1702 x 2134. Specify as 1700 x 2100, but approve the standard english size)

Note: Code and criteria requirements may restrict this approach and must be considered on each project.

Speeds should be in m/s, shown to 2 digits.
(ex, 0.64 m/s, 0.51 m/s)

Thus mfrs supply standard product, and rounded numbers appear in specs, drawings, and to the public.

Architectural / Glass

ASTM C1036 gives metric sizes for flat glass, heat absorbing glass, and wired glass. Glass shall now be specified in mm only. Thicknesses for Type 1, Transparent Flat Glass: 1, 1.5, 2, 2.5, 2.7, 3, 4, 5, 5.5, 6, 8, 10, 12, 16, 19, 22, 25, 32

Architectural / Landscaping

Products should be specified in rounded increments. We recommend the following, wherever possible:

Inches x 25 = mm (ex, 2 inch x 25 = 50 mm)

This should be used for description of existing landscaping, as well as new items.

Architectural / Lighting Fixtures

Most common sizes are 600 x 600 and 600 x 1200. Many firms say it is easier to supply 600 x 600, since U tubes do not restrict housing sizes from being made slightly smaller.

Architectural / Lumber

AFPA recommends the designations often used in Canada. Products are not changed. This chart gives actual mm-nominal inches. (ex, 38 x 89 replaces 2 x 4)
38-2 63-3 89-4 114-5 140-6 165-7 184-8
210-9 235-10 260-11 286-12 337-14 387-16

Our experience shows people use mm dimensions in exact layout work only, such as layout of cabinetry, but verbally they still use 2 x 6, 2 x 10, etc.

Architectural / Plywood

Many firms often make metric plywood, and others can make many grades, thicknesses, and panel sizes.

Most firms prefer one truckload as the minimum order, which can generally include different thicknesses.

It generally takes 2-3 weeks for delivery.
Costs will be comparable to english sizes.

Projects using plywood should specify metric sheets.

Thickness is the same to minimize production impact. Standard are 12.7 and 19.05 mm, commonly given nominal thicknesses on drawings (ex, 19 mm)

While it may sound contrary to the spirit of conversion, suppliers indicated they should decide the least costly way to supply metric sheets.

Many mills cut 4 x 8's to smaller sheets for furniture. They say 20-50 metric sheet orders could be cut locally from 4 x 8 to 1200 x 2400 for less than fabricating it and shipping it from a major mill across the country, until 1200 x 2400 becomes commonly available. We focus on specifying stud spacing and allow industry to innovate supply methods.

Architectural / Renovation

Renovation is more difficult than new construction, metric or english.

The difficulty of metric renovation can be minimized through use of the following and other techniques.

Examples are simplified to demonstrate the principles.

One Bad Rule

This technique can be utilized to minimize awkward metric numbers. Any existing space dimension, no matter how awkward, can be developed as a series of clean, rounded metric numbers, combined with one awkward metric number.

Ex, if two existing walls are located 12 043 mm apart on a renovation project, this could be laid out as:

1400 + 3600 + 4200 + 1200 + one bad, or 1643

This is ofcourse simplified, but it is a noble goal in renovation, and if the majority of situations utilize this technique, the awkward numbers can be minimized.

Off The Wall Technique

In addition, if the first four dimensions above are such that the spaces can be laid out off one wall, the 1643 will not be used, although it will probably be checked initially to confirm overall accuracy.

Ex, $1400 + 3600 + 4200 + 1200 = 10400$

With this approach the layout work is all done in rounded metric units off one wall, and the 1643 is a floating dimension. Layout is done to the maximum of 10400 only, all with clean numbers.

Metric Core Technique

With the same example above, our space of 12043, we can use the metric core technique.

If either wall is to have stud and drywall applied, we can take up the slack to establish a hard metric core. If we use 92 mm metal studs, 16 GWB, and move the stud 35 mm out from the existing wall, we establish a 143 mm floating zone. A rounded, 11900 dimension is now established as the metric core.

Equal Technique

If both walls are to receive drywall facing, we can use 92 studs and 16 GWB both sides, plus indicate an equal distance from each existing wall to the metal stud, to create a total metric core of 11800. The equal distance would be 13.5 mm equal on each side, making 121.5 each side, times 2 equals 243, leaving 11800. The 13.5 could be shown only as Equal on drawings.

Soffit Technique

In some facilities, we utilize soffit ceiling techniques to take up the awkward difference around the edge, so we can utilize hard metric ceilings. In our example, 18 metric 600 mm ceiling tiles, plus a 100 mm border, would give 11 m. An equal soffit space of 521.5 would work nicely as a border, and would equal our 12043 dimension.

The majority of dimensions involved with renovation or new construction involve new dimensions. Ex, no one is reconstructing a bay spacing in an existing building, since it already exists. The frequently utilized dimensions in renovation consist of dimensions which can be stated in rounded, hard metric dimensions to a large degree.

Architectural / Roofing

Use m2 for areas, instead of the 2 previous units.

State membrane thickness in mm only.

Lap widths should be even mm. (ex, 100, 150 mm)

Architectural / Sheet Metal

We have found very little difficulty showing dimensions in mm thickness only in specifications.

While several people indicated it would be simpler to leave gage, we feel specifying mm thickness eliminates all confusion, and still allows standard products to be supplied, since specifications give minimum thickness.

Our projects are now moving toward showing minimum thickness in mm only.

We recommend specifying in even 1 or 0.1 mm thickness wherever possible. (ex, 1 mm, 1.6 mm)

Most overseas references we see also utilize either 1 or 0.1 mm increments.

From our research, hard metric sheet metal is obtainable, even in smaller quantities.

Architectural / Slope

There is benefit to using % for slope.

Rule: Percent x 10 = mm/m (mm per meter drop)

Ex: 2 % x 10 = 20 mm/m, 45 % = 450 mm/m

We recommend using % instead of ratios (ex, 1:12), wherever possible.

Architectural / Stone

Stone, such as granite and marble, should be specified in hard metric (ex, 30, 50 mm thick, or 100 x 300)

We have contacted many domestic companies able to produce required hard metric stone sizes.

Architectural / Studs

We have seen several conversion systems, and propose to call common metal studs by these nominal mm sizes, which closely align with the dimensions in the standard:
42 64 92 102 153 mm

A 22 mm hat channel for furring is also common.

Architectural / Woodwork

Custom casework, such as cabinets, built-in benches, shelves, security desks, and judges benches, should be developed in hard metric to the fullest degree possible.

Dimensions should follow the ratchet technique.

Cabinets Many cabinet widths we have seen are shown as increments of 50 mm. (ex, 450, 500 mm wide)

Lockers in childcare have been seen as 250 mm wide.

Civil / Concrete

Concrete is now being widely specified throughout the country in MPa. Strengths are stated in 5 MPa increments: 20, 25, 30, 35, 40, 45, 50, etc.

20, 25 and 30 MPa are the most common.

ACI 318 M, metric version, should now be used.

Slump Limits on metric projects always use 10 or 5 mm increments. (ex, 75, 80, 90 mm)
Some Canadian documents state increments of 10 mm are to be used. (ex, 80, 90, 100 mm)

Civil / Concrete Pipe

ACPA states concrete pipe can now be specified using hard metric ASTM and AASHTO standards, as is currently done in Canada.

Reinforced concrete pipe is now being specified on our projects as ASTM C76M / AASHTO M170M.

Current C76 RCP will meet the hard metric standard, as tolerances were set in the hard metric standard to accept current product.

Nonreinforced concrete pipe will be specified as ASTM C14M / AASHTO M86M.

C76M sizes: 300 375 450 525 600 675 750 825
900 1050 1200 1350 1500 1650
1800 1950 2100 2250 2400 mm

C14M sizes: 100 150 200 250 300 375 450 525
600 675 750 825 900

Civil / Geotech

Geotech reports shall be SI units only, and equally importantly, shall be in rounded SI units. Bearing and side frictions values shall be in MPa, rounded to 1 or 0.1 MPa increments wherever possible.

Failure to state bearing values in even MPa will cause english values to be utilized throughout the project. Example: Conversion of an english value to 1.437 MPa will not cause people to use this number, whereas rounding to 1.4 or 1.5 MPa, if technically possible, produces a number easy enough to incorporate into common daily use.

Show anticipated settlements in even mm sizes.
Location plans and boring plates shall be to metric scales, and shall have metric graphic scales only.

Soil profiles and boring logs shall show even meter depth increments only. Bearing value contours shall be in meters. Describe boring equipment, such as barrels and hammers, in SI units only.

Civil / GIS

Many Geographic Information Systems and AM/FM systems for mapping, gas, electric, and water distribution mgmt, wastewater systems, and other infrastructure elements, will operate in SI.

Delta Data MS, offers AGIS, Adv Geographic Informatn System, which runs in SI. 601 799 1813

ESRI CA, produces ARC/INFO, a market leader in the GIS market as well as the utility market, which will work completely in metric. 909 793 2853 x 1375

Facility Mapping Systems CA, produces several software packages that operate in metric:
FMS / AC Municipal (DPW and Planning)
FMS / AC Public Works (infrastructure mgmt)
FMS / AC Utility (electric, gas, water systems)
Gregg Smith 800 442 3674 415 381 1750

Intergraph AL, produces GIS software that can run in metric. John Hacker 205 730 1705

Scott and Scott Systems WA, a prominent electrical utility GIS software producer, offers DMS/G, which can operate in a metric environment.
Susan Varga 800 325 1494 206 441 1804

Our sources also indicate the Global Positioning Satellite (GPS) system is already in metric.

Civil / Infrastructure

We have had contact with many firms able to build infrastructure projects in metric. (ex, waste water and water treatment plants) We are placing this material in the next M1 version.

Civil / Reinforcement

Availability of metric rebar will be variable over the next 1-2 years. Minimum orders vary significantly.

All projects shall now specify hard metric rebar.

Projects let to construction during low supply periods shall, as a concession to our friends in industry, utilize the rebar substitution developed by the Reinforcing Steel Inst of Canada (RSIC), until the formal CRSI system is issued, which we will immediately adopt.

Claim of lack of availability should be backed up by a comprehensive industry product search.

RSIC used M suffixs (ex, 20M) to avoid confusion, which we will use. Recent CRSI material uses this.

Metric rebar is made by a few producers, and others indicated they will produce it. To assist US firms, limit number of metric bars to the fewest possible per job.

Several DOTs (MO TX VA) and other engineers, were concerned over lack of a metric bar for the No 4.

Canadians had significant discussion on whether 12M should have been added. Through the years, it was decided to stay with the existing series.

Survey From an 8/93 survey of state rebar conversion and metric activity, 19 DOTs had incorporated metric bar into criteria (ex, standard drawings and specs) or would do so within 6 months. (AK AL CA DE FL IA IL KS KY LA MD MS NC OK PA TX VA VT WA)

Three states were not sure if it would be incorporated into criteria within 6 months. 14 states said it would not be incorporated within the next 6 months. 14 states did not respond.

Subsequent discussions have verified that many of the 6 month projections have been realized.

Size	Diam (mm)	Area (mm ²)	Size	Diam (mm)	Area (mm ²)
3	9.52	71	10M	11.3	100
4	12.70	129	15M	16.0	200
5	15.87	200	20M	19.5	300
6	19.05	284	25M	25.2	500
7	22.22	387	30M	29.9	700
8	25.40	510	35M	35.7	1000
9	28.65	645	45M	43.7	1500
10	32.25	819	55M	56.4	2500
11	35.81	1006			
14	43.00	1452			
18	57.32	2581			

Welded Wire Fabric WRI is currently developing a series of hard metric wire diameters. Many firms make their own dies and can make any size diameter. Some firms, mostly those with newer variable step spacing equipment such as EVG, Schlotter, or BSG, are able to produce metric spacing (ex, 150 x 150), but minimum orders are significant, ranging from about 15 Mg to much higher minimum orders. Look to WRI for shortly forthcoming metrication guidance.

Civil / Roads

Road Design States are roughly divided on use of km or 100 meter stations. AASHTO recommends km stations. Projects may use either at this time.

Use AASHTO Standard R1, equal to ASTM E380, for metric practice.

Federal Highway Administration directed that all construction using federal funds after October 1996 must be designed using the metric system.

The state response has been decisive in many areas, as many states have established dates earlier than that, setting dates in 1995, after which their highway construction will be metric.

Many major state and local highway projects starting now or in the near future are being done in metric.

Federal, state, and local agencies are already doing metric road and bridge design, with some already in or near construction.

Most states have begun converting standard drawings and specifications to metric. See M1 for details.

See the Road Design Data section for more detail.

Right of Way (R/W) Critical issues appear to be public response to SI, and legal acceptance. Our site acquisitions, ie r/w purchases, should use technique 1 below, unless not possible, then use technique 2:

1. Hard Metric Only: 100 m
2. Hard Metric / Soft English: 100 m (328.08')

With method 2, when SI is used exclusively, english can be deleted and numbers will be even metric.

This of course applies only to site acquisitions of uniform geometry (ex, long stretches of 100 m wide r/w) For site acquisitions of uneven geometry, SI and english dimensions will often involve uneven numbers.

We use AASHTO 1993 Guide To Metric Conversion, for geometric design values, lane and shoulder widths, curb heights, sight distances, curvatures, other material. Phone Orders: AASHTO 202-624-5800

Civil / Sitework

Sitework, such as location and placement of utility feeds, is among the easier portions of work to do in metric. Surveyors already work in decimal units, and most field personnel indicated switching to metric involved little if any effort.

Our regional electronic surveying and mapping equipment provides data in metric. Many states also utilize electronic data measurement (EDM) equipment which almost always can work in metric units.

Civil / Surveying

Two primary agencies producing survey data are National Geodetic Survey (NGS) and US Geological Survey (USGS). SI database information is available.

NGS horizontal and vertical control point network has been SI since 1983. Benchmark elevations are meters.

UTM and State Plane Coordinates Systems are metric.

Almost 40 states have adopted metric in their state plane coordinate systems.

Project Data

Most engineers are now using meters for survey elevations, contour intervals, and large scale site drawings. Feel free to use m or mm.

Convert benchmarks from feet to m or mm.
Ex, 314.15 feet becomes 95.753 m (95 753 mm)

Smart Technique We have seen large mapping scales use SI symbols. 1:2000 was written as 1:2k, 1:5,000,000 as 1:5M.

Electrical

Conduit will not physically change by switching to metric. It becomes classified by a nominal mm size.

There has been significant discussion among our partners at NEMA and in the conduit manufacturing field regarding designations of various conduit types.

Most important is these products will be physically identical. Look to NEMA for future guidance.

Wire Size Almost all cable firms contacted make metric sizes for export, or can make them. Minimum orders vary.

Projects with medium and larger wire requirements may wish to start using international sizes, where permitted by governing codes and criteria.

Many projects have begun to refer to existing sizes by mm² dimensions, to become familiar with mm² scale.

These are mm² equivalents with detailed rounding. In some cases, rounding to nearest 0.1, 1, or more mm² may be feasible. Use professional judgement.

AWG-mm² 22-0.506 20-0.517 18-0.82 16-1.31
14-2.08 12-3.31 10-5.26 9-6.6 8-8.37 7-10.6
6-13.30 5-16.8 4-21.15 3-26.66 2-33.63 1-42.41
1/0-53.48 2/0-67.44 3/0-85.03 4/0-107.2

kcm-mm² 250-126.68 300-152.01 350-177.35
400-202.68 450-228.0 500-253.4 550-278.7
600-304.0 650-329.4 700-354.7 750-380.0
800-405.4 900-456.0 1000-506.7 1100-557.4
1200-608.1 1250-633.4 1300-658.7 1400-709.4 1500-
760.1 1600-810.7 1700-861.4 1800-912.1 1900-962.7
2000-1013.4

ASTM B682 gives metric sizes. Common sizes are:

0.5, 0.75, 1, 1.5, 2.5, 4, 6, 10, 16, 25, 35, 50, 70, 95, 120, 150, 185, 240, 300 mm²

Fiber Optics It was falsely reported in the last edition that fiber optic cables would be soft converted. Most cables are made to metric dimensions, so these will be specified in hard metric. (ex, 125 um fiber cable)

Illumination levels are in lux (lx). Specify lux values using the ratchet technique, where feasible and allowed by criteria. 1 FC ~ 10 lx; thus rounding a few lx may have little impact.

Environmental

The environmental field has been progressive regarding SI. Many regulations have been metric for years.

Based on review of commonly used environmental data, projects shall now specify metric only.

Estimating

Time We find metric design and construction take the same number of months as english projects. No adjustments have been made to time expectations.

Cost Estimating shall be done in metric units only.

Design Costs There will be no change to the standard design fee charts used to calculate design costs.

Now that 1) specs are SI 2) SI estimating tools are offered 3) criteria is SI 4) most codes and standards have SI 5) sample drawings exist for most items, we cannot justify uniform premiums for metric design.

Construction Costs Bids to date have not shown detectable premiums for metric. No additional funds are being allocated for metric construction.

We would welcome comparing detailed cost analysis which yields results contrary to this conclusion.

Estimating Tools are offered by many prominent firms.

Building System Design GA, offers metric estimating software. Larry Hendrix 404-876-4700

Cost Engineering Technologies NJ, offers a metric database. Kenneth Browne 201-335-1707

MCASES Gold, DOD database, operates in metric.

MC2 (MC Squared) TN, offers a metric database. Billy Telford 901-346-9880

R.S. Means MA, 800-448-8182, offers metric estimating handbooks. Database available in late 1993.

Timberline OR, offers a metric database. Ann Kenkel Curtis Peltz 503-626-6775

US Softcost GA, offers their Success metric database. Louis Parkins John Williams 800-955-1385

Mechanical / General Fasteners

With major sectors of US industry now using metric fasteners extensively, there is virtually no fastener that is not obtainable in mm sizes.

It is hard to imagine a well known manufacturer that does not stock, regularly make, or have the capability to produce metric products.

Thomas Register has hundreds of firms under Metric Fasteners, Metric Screws, and Metric Bolts.

IFI offers guides of fastener types and producers. Most firms in the division 4/5, covering some common construction fasteners, indicate metric ability. IFI Metric Fastener Standards (530 pg) has technical data, selection hints. IFI, 216 241 1482

Many pieces of mechanical and electrical equipment already use both metric and english fasteners.

Metric fasteners use M numbers. (M10 x 40 is nominal 10 mm diameter, 40 mm length)

Some states already stock some metric nuts and bolts. (ex, Colorado Department of Transportation)

To conserve paper, we will not list the over 150 firms that stock or produce general metric fasteners. We will list suppliers only for fasteners often used in construction, which are not stock items yet.

The following two charts provide information on fasteners. Our source cautioned that the material is several years old and is soon to be revised, so standards references should be confirmed prior to specification of products.

Conclusion

Our projects are now using metric socket head cap screws, set screws, hex bolts, and similar items, whenever needed, in any quantity. These have been stock for years and available at about the same cost.

Mechanical / Anchor Bolts

All new projects are specifying metric anchor bolts (ex, L, J, and U bolts). ASTM F568 gives metric chemical and mechanical data for carbon steel anchor bolts and studs, and references ANSI dimensional standards. No metric version of A307 is planned.

ISO Metric Grades as given in ISO 898 and ASTM F568, should be used. Many anchor bolts are made from low carbon steel grades, such as ISO classes 4.6, 4.8, and 5.8.

Many firms indicated no minimum order quantity, but some stated there would be premiums related to set up costs for very small orders.

Preferred Diameters

From material we have seen, it appears preferred nominal diameters for items such as anchor bolts and threaded rod, would be as shown below.

Reference individual standards prior to specification.

Sizes are given between M5 and M45, as these are commonly used sizes in construction.

1: = 1st preference, 2: = 2nd preference, etc.

1: M5 6 8 10 12 16 20 24 30 36 42

2: M14 18 22 27 33 39 45

3: M5.5 7 9 11 15 17 25 26 28 32 35 38 40

Mechanical / Fastener Data

Basic Product	Product Type and Head Style	Size Range	For Dimensions Refer To (See Note 1)	For Mechanical and/or Performance Properties Refer To (See Note 1)
Metric Bolts	hex	M5-M100	ANSI/ASME B18.2.3.5M	ASTM F568 ASTM F468M ASTM F738
	heavy hex	M12-M36	ANSI/ASME B18.2.3.6M	
	round head short square neck (carnage)	M6-M20	ANSI/ASME B18.5.2.1M	
	round head square neck (carnage)	M5-M24	ANSI/ASME B18.5.2.2M	ASTM A325M ASTM A490M IFI 541
	bolt	M5 and larger	IFI 528	
	heavy hex structural	M12-M36	ANSI/ASME B18.2.3.7M	
	hex transmission tower	M16-M24	IFI 541	
Metric Screws	hex cap	M5-M100	ANSI/ASME B18.2.3.1M	ASTM F568 ASTM F468M ASTM F738
	formed hex	M5-M24	ANSI/ASME B18.2.3.2M	
	heavy hex	M12-M36	ANSI/ASME B18.2.3.3M	
	hex flange	M5-M16	ANSI/ASME B18.2.3.4M	(See Note 3)
	heavy hex flange	M10-M20	ANSI/ASME B18.2.3.9M	
	hex lag	5-24mm	ANSI/ASME B18.2.3.8M	
Metric Socket Screws	socket head cap	M1.6-M48	ANSI/ASME B18.3.1M	ASTM A574M F837M
	socket head shoulder	6.5-25mm	ANSI/ASME B18.3.3M	ASTM F835M
	socket button head cap	M3-M16	ANSI/ASME B18.3.4M	ASTM A574M
	socket countersunk head cap	M3-M20	ANSI/ASME B18.3.5M	ASTM F879M
	socket set	1.6-24mm	ANSI/ASME B18.3.6M	ANSI/ASME B18.3.6M ASTM F912M ASTM F880M
Metric Studs	double end	M5-M100	IFI 628	ASTM F568 ASTM F468M ASTM F738
	continuous thread	M5-M100		
Metric Locking Screws	prevailing-torque, non-metallic insert	M1.6-M36	(See Note 3)	IFI 624
	chemical coated	M6-M20	(See Note 3)	IFI 625
Metric Nuts	hex, style 1	M1.6-M36	ANSI/ASME B18.2.4.1M	ASTM A563M ASTM F467M ASTM F838M ASTM A194M
	hex, style 2	M3-M36	ANSI/ASME B18.2.4.2M	
	slotted hex	M5-M36	ANSI/ASME B18.2.4.3M	
	hex flange	M5-M20	ANSI/ASME B18.2.4.4M	
	hex jam	M5-M36	ANSI/ASME B18.2.4.5M	
	heavy hex	M12-M100	ANSI/ASME B18.2.4.6M	
Metric Prevailing-Torque Nuts	hex, steel	M3-M36	ANSI/ASME B18.16.3M	ANSI/ASME B18.16.1M
	hex flange, steel	M6-M20		ANSI/ASME B18.16.2M

Mechanical / Fastener Data

TABLE 4. MECHANICAL REQUIREMENTS FOR CARBON STEEL EXTERNALLY THREADED FASTENERS—METRIC SERIES

Property Class Designation	Nominal Size of Product	Material and Treatment	Mechanical Requirements						Property Class Identification Marking
			Proof Load Stress, MPa	Yield Strength, MPa, Minimum	Tensile Strength, MPa, Minimum	Product Hardness, Rockwell C ¹			
						Surface Maximum	Minimum	Maximum	
4.6	M5-M100	low or medium carbon steel	225	240	400	—	B67	B95	4.6
4.8	M1.6-M16	low or medium carbon steel, fully or partially annealed	310	340	420	—	B71	B95	4.8
5.8	M5-M24	low or medium carbon steel, cold worked	390	420	520	—	B82	B95	5.8
8.8	M16-M72	medium carbon steel; the product is quenched and tempered	600	680	830	30N56	C23	C34	8.8
A325M Type 1	M16-M36	medium carbon steel; the product is quenched and tempered	600	680	830	30N56	C23	C34	A325M 8S
8.8	M16-M36	low carbon boron steel; the product is quenched and tempered	600	680	830	30N56	C23	C34	8.8
A325M Type 2	M16-M36	low carbon boron steel; the product is quenched and tempered	600	680	830	30N56	C23	C34	A325M 8S
A325M Type 3	M16-M36	atmospheric corrosion resistant steel; the product is quenched and tempered	600	660	830	30N56	C23	C34	A325M 8S3
9.8	M1.6-M16	medium carbon steel; the product is quenched and tempered	650	720	900	30N58	C27	C36	9.8
9.8	M1.6-M16	low carbon boron steel; the product is quenched and tempered	650	720	900	30N58	C27	C36	9.8
10.9	M5-M20	medium carbon steel; the product is quenched and tempered	830	940	1040	30N59	C33	C39	10.9
10.9	M5-M100	medium carbon alloy steel; the product is quenched and tempered	830	940	1040	30N59	C33	C39	10.9
A490M Type 1	M12-M36	medium carbon alloy steel; the product is quenched and tempered	830	940	1040	30N59	C33	C39	A490M 10S
10.9	M5-M36	low carbon boron steel; the product is quenched and tempered	830	940	1040	30N59	C33	C39	10.9
A490M Type 2	M12-M36	low carbon boron steel; the product is quenched and tempered	830	940	1040	30N59	C33	C39	A490M 10S
A490M Type 3	M12-M36	atmospheric corrosion resistant steel; the product is quenched and tempered	830	940	1040	30N59	C33	C39	A490M 10S3
12.9	M1.6-M100	alloy steel; the product is quenched and tempered	970	1100	1220	30N63	C38	C44	12.9
Notes: 1, 5	4		2	2	2				3

Notes:

- For uses and source of availability of ISO 8801, ASTM F568 and the other referenced ASTM specifications refer to page 86. When only the property class number is shown, the class is standard in both ISO and ASTM documents. The properties specified in each are identical except for only a very few minor exceptions. Where differences exist, the F568 values are given.
- To compute the proof load, yield strength or tensile strength, in kilonewtons, for a bolt, screw or stud, divide the stress value, MPa, as given in Table 4 for the property class by 1000 and multiply the answer by the tensile stress area of the product's screw thread as given in Table 2, page 32.
- In general, identification markings shall be located on the top of the head and preferably shall be raised.
- Class 5.8 products are available in lengths 150mm and shorter only.
- Caution is advised when considering the use of Class 12.9 products. Capability of the fastener manufacturer, as well as the anticipated service environment, should be carefully considered. High strength Class 12.9 products require rigid control of heat treating operations and careful monitoring of as-quenched hardness, surface decarburization, depth of partial decarburization and freedom from carburization. Some environments may cause stress corrosion cracking of nonplated as well as electrolytic processes.

Mechanical / HVAC

Air Flow out of grilles and diffusers should be rounded to even increments of 5 or 10 L/s, wherever possible.

Ductwork (Round, Rigid) Most designers are showing hard metric diameters. (ex, 250, 300)

Ductwork (Round, Flexible) Many designers are showing flexible round duct in hard metric sizes, but accepting soft metric during construction. (ex, 200, 250)

Ductwork (Rectangular) Use 50 and 100 mm sizes, (ex, 500 x 1000, 250 x 350) unless not possible.

Equipment We regularly receive updated catalogs from producers that have added metric data to their catalogs or literature. Where this did not exist, we have had no difficulty receiving modified data on a project, or obtaining a bond paper supplement.

Schedules To think metric, flow rates, pressures, thermal powers, and other criteria on schedules should be rounded wherever possible.

The 1 % Analysis provides a useful technique.

Ex 1, A fan flowrate converts to 8,022 L/s. 1% is +/- 80.22 L/s. This fan could possibly be shown as minimum 8000 L/s (8 m³/s) and is easier and faster to say.

Ex 2, A pump flow converts to 75.7 L/s. 1 % of this is 0.757 L/s. 75 L/s could possibly be used.

It is important to note that in some cases codes or design criteria may not allow this liberty. In other cases however, 2 or 3 % analysis may be feasible, and could lead to rounded, easily spoken numbers.

Temperature People will rarely speak in decimal degrees. (ex, 23.8 degrees C). All mechanical schedule temperatures, design temperatures, leaving and entering temperatures, and others shall be stated in even Celcius (ex, 5, 12, 25, and 40 degrees C) unless not possible.

New construction projects shall use Celcius only.

Renovation projects where new control systems are being installed, should use Celcius.

HVAC calculations shall be in SI to the fullest extent possible.

Thermal Ratings for boilers and chillers should be specified in even nominal MW or kW increments to the largest degree possible:

(Ex, 500 kW, 0.9 MW, 3.5 MW)

Pipe Steel pipe (ASTM A53) and copper tube sizes (ASTM B88) will not physically change by switching to the metric system. They are now classified by new nominal mm sizes.

ASTM B88M, hard metric copper tube sizes, should not yet be utilized.

Schedule designations remain the same (example: Schedule 40, and type K,L,M)

The Mechanical Task Group, under leadership of ASME, recently recommended use of 18 mm for 5/8, instead of the 16 stated in the last guide.

All other designations remain the same.

Metric pipe designations are:

15 18 20 25 32 40 50 65 80 90 100 125 150 mm

Over 150, inch x 25 = mm (24 " x 25 = 600 mm)

Units Use units from the ASHRAE SI Guide.

Structural

The primary lesson learned is design dimensions must be rounded dimensions. Bar spacing, wall and slab thickness, and similar dimensions, shall be even mm (100, 250, 400 mm) not conversions. (ex, 305 mm)

Calculations End results of structural calculations, and all summary data shall be SI. Calculations shall be SI to the fullest degree feasible.

Cambers State in even mm. (ex, 20, 22 mm)

Floor Load capacity is specified in kPa.

Significant hinderance to use of kPa has been allowing dual dimensions. No feel for kPa is acquired unless kPa only are used.

Our typical office rating is 5 kPa: with 4 kPa and 1 kPa components. Drawings and calculations should reflect these numbers only.

In existing facilities, it is preferred to convert values to exact kPa and round to next lowest 0.1 kPa, unless strong reasons exist not to use this method.

Ex 1, A load capability exactly converts to 9.58 kPa. Round to 9.5 kPa. This is rounded, easy to remember, less than 1 % error.

Ex 2, at Richmond VA Federal Building renovation:

"Existing Structure Allowable Live Load Per Original 1959 Building Plans Are As Follows:

Lobbies, Stairs, and Corridors	4.8 kPa
Toilets	2.9 kPa
All Other Areas	3.8 kPa"

Situations needing mass loading might use the following rounded, slightly conservative, rule:

$kPa \times 100 = kg/m^2$ (5 kPa \times 100 = 500 kg/m²)

Steel Deck thicknesses are being soft converted (ex, 38 mm).

Structural Steel shall be specified in SI only, such as 250 MPa. Shapes shall be specified according to the millimeter sizes and dimensions in ASTM A6M.

Welds are shown in even mm sizes. (ex, 5, 6 mm)

Wind Pressures are given in Pa.

Wind Speeds are most frequently given in m/s.

Preparation

Standard regional procedure is as follows:

Internal Preparation

Project managers starting a metric project receive:

- 1) This design guide
- 2) Metric scale
- 3) 1 hour metric design orientation course
- 4) Metric / english tape measure (if needed)

Most people (except field inspectors) use tape measures infrequently after a few months of daily metric usage.

Metric training cannot have the same training effect as immersion into metric design or construction.

We did not purchase metric conversion calculators.

External Preparation For Design Firms, Construction Managers, and Real Estate Developers

1. Provide this design guide to staff members
2. Metric experience can only be a plus, as federal, state, and local government projects increasingly go metric. To obtain experience, consider using metric for other government or private projects.
3. The architectural and engineering communities have in general responded favorably to metric conversion. We have not provided wholesale training to all firms that commonly do business with us. We provide detailed consultation (~ 2 hours if needed) once firms sign contracts and are about to start design.

External Preparation for Product Manufacturers

Contacts with product manufacturers should now always discuss available metric products and literature, although many have been exposed through projects.

Submissions have unfortunately been returned for resubmittal based on lack of understanding of the firmness of this requirement. This can be avoided by thorough communication.

Construction Firms, Construction Personnel

Agencies like New York State Department of Transportation are working with local AGC chapters to alert contractors of upcoming metric activities. Our construction management firms have helped us by also contacting AGC, unions, other construction related groups, to advise of upcoming metric projects.

Design Policy

Selection of pilot projects is an important factor in whether a metric project will be successful.

All projects need not be done in metric now.

National policy requires all projects be in metric after January 1994. Our regional policy, in place since January 1992, shall remain prior to that time.

As our major capitol project designs have been metric for some time, the vast majority of all major project construction dollars in 1994 will be metric.

Regional Design Policy All renovation and new construction projects of \$ 500,000 or more, shall be done completely in metric.

All specifications for new construction lease projects shall be metric. The same firms that provide construction services to developers on lease projects perform construction for us in direct federally funded projects.

Projects under \$ 500,000 may be done in SI, based on feasibility. About half of our projects under \$ 500,000 are currently selected for metric design.

Feasibility of doing projects below \$ 500,000 is based on the number of hard metric products used. Small projects using mainly soft metric products can usually be easily done in metric.

Very small projects under \$ 50,000 are generally not being done in metric yet.

Timeframe To Convert Projects To Metric

Our past year reinforces earlier policy: It is fully feasible to convert medium and large projects to metric up to about 25-30 % design completion.

This can be up to about 40 % for smaller projects.

For CAD drawings, it is usually easy to convert to SI and select similar metric structure dimensions.

Many projects nationwide, at the federal, state, and local levels, have now been converted to metric up to the 30% design stage, with success.

CAD While regional policy requires all projects be 100 % CAD, projects are being done nationwide in metric in freehand format with little difficulty.

AE / CM Advertisements

As required for the past 2 years, advertisements for Architectural/Engineering (AE) or Construction Management (CM) services shall be as follows:

1. State areas in m2 only. (ex, The new building will be approximately 40,000 net square meters)

2. Each announcement shall state: "This project will be designed and built entirely in metric units."

3. For A/E firm announcements, including term contracts, this is a required evaluation factor:

"Familiarity with SI and ability to design in SI units." This will typically be 10-15 % of the evaluation.

Each responding firm must continue to submit a one page summary of their SI experience, familiarity with SI, and ability to design in SI units.

Metric experience though is not mandated.

Almost half of the 500 largest US design firms, which design many of our medium and large scale projects, did overseas work last year, much of which was SI.

Based on our experience though, size of firm has not been a determining factor. Many small, medium, and large firms are producing high caliber metric designs.

4. For CM (Construction Manager) ads, including term CMs, this remains an evaluation factor:

"Familiarity with SI and ability to perform required services in SI units." A one page summary must also be submitted. (similar to above)

5. Each CBD announcement shall state:

"The GSA Region 3 Metric Design Guide is available free to bidders upon request.

Construction Advertisements

Advertisements for construction projects shall:

1. State project area in m2 only.

2. State "This project was designed in metric. Inspection will take place in metric. Submittals must be provided in metric units.

3. State: "The GSA Region 3 Metric Design Guide is available free to bidders upon request.

Note: The Metric Design Guide can be a good orientation document, which can contribute to the overall project success. Bidders will be able to ask better questions at the prebid conference if this guide is available to them in advance."

AE / CM Scope Guidance

AE scope guidance can be stated as follows:

Design on this project shall take place in conformance with M2, The GSA Region 3 Metric Design Guide.

Submittals

To assist manufacturers with metric conversion, we recommend the following submittal classes be utilized.

Classes should be supplemented for each project.

Please contact us regarding detail of items listed here.

There is gray area in this classification system.

Our guiding principle is that if a construction firm makes an honest, good faith effort to comply with metric guidance, then we should work with them and allow minor variations where needed to promote the greater goal of smooth, overall transition.

We would generally encourage project managers to push non-essential submittals into class 3 wherever feasible.

Class 1. Drawings That Must Be Metric Only

English units are not permitted on these submittals. Drawings must use metric scales. In general, any drawing that is job specific, and is custom generated for this project, must be in metric only. These are some samples:

- . All Floorplans
- . Reflected Ceiling Drawings
- . Stairwell Erection Drawings
- . Foundation Wall Drawings
- . Concrete / Rebar Installation Drawings
- . Sitework Drawings
- . Sheeting and Shoring Plans
- . Steel Erection / Fabrication Drawings and Details
- . Precast Manhole Drawings
- . Door Schedules
- . Wall Paneling Drawings
- . Caisson Details
- . Millwork drawings
- . Cabinet Work Details
- . Toilet Room Details
- . Ductwork Submittals
- . Pipe Installation Drawings
- . HVAC Schedules
- . Switchgear Drawings
- . Electrical Component Layout Drawings
- . Signage Drawings

Class 2. Data That Must Be Metric Only

Following types of items must be submitted in SI only.

Primarily, any data generated specifically for this project must be submitted in SI only.

- . Concrete Design Mixes
- . Concrete Test Data
- . Core Bore Depths and Data
- . Aggregate Mixes Must Show Metric Sieves
- . Mechanical Air and Water Flow or Balancing Data
- . Environmental or Hazardous Material Data
- . Most Test Data of various natures
- . Other data generated for this project, not in bound, preprinted catalogs or publications.

To absolutely minimize the time and cost impact of metric conversion, we have recommended an additional class of submittal data.

This allows us to meet the national mandate of complete metric conversion, while allowing the extensive body of technical information to be fully converted over a period of a few years.

We understand that the time and cost associated with sudden conversion of handbooks and product literature can be significant, and have attempted to avoid that.

Class 3. Metric Supplement Required

Requires existing pre-printed literature to be supplemented to show conformance with requirements stated in the specification or on drawings.

Supplements can be:

1. Bond Paper Supplement
2. Handwritten Or Typed On Existing Literature
3. Other Approved Method

Examples:

Steel Deck Data

The entire product literature does not need to be converted, only those numbers sufficient to show that the sizes submitted are those sizes required (such as 38 mm, etc). The bond paper supplement would state the 1.5 inch deck is equal to 38 mm.

Epoxy Adhesive Literature must only show conformance with requirements specifically shown in the specs.

Preprinted Mechanical / Electrical Equipment Catalogs

need not be converted. However, conformance with specified and scheduled flowrates, pressures, temperatures, thermal output rates, etc, must be demonstrated.

Physical dimensions of mechanical and electrical equipment shown on project specific installation drawings are Class 1, and must show metric only.

Typical eqpmt: Boilers, AHUs, Chillers, Terminal Units, Pumps, Exhaust Fans, Switchgear, Pumps, Transformers, UPS systems, Fire Alarm Eqpmt, etc.

- . Elevator Component Data
- . Bathroom Component Details
- . Mini-Blind Data
- . Roof Hatch Sizes
- . Metal Ceiling Grid Data
- . Access Floor Tile Data
- . Plumbing Fixture Data
- . Metal Stud Data
- . Structural Bolt Data
- . Paint Literature
- . Formwork Release Agent Data
- . Valve, Pipe, and Fittings Data

We have found that a major portion of firms supplying submittal data already have their data available in either metric only or dual dimensioned format.

We can provide sample acceptable submittals to government agencies for virtually any product.

01 Tools

Metric tape measures are available.

Some construction firms are using metric only tapes.

Federal agencies can buy 10 ft/3.3 m tape measures on GSA schedule. Product # 5210-00-086-4988, under \$5.

Lufkin Tools NC, makes metric tape measures.
919-362-7511

Stanley Tools CT, makes metric measures.

32-156 (5 m) 32-158 (5m/16')

33-443 (10 m) 33-428 (7.5m/25')

Carl Lickwar, Alan G. Martin 203- 225-5111

Metric framing squares have also been ordered from Stanley by the US Public Health Service.

Stanley Hand Tools CT, 800- 262- 2161

US Tape VA, makes metric tape measures, steel tapes, and derrick tapes. W. S. Spotswood 703- 256-1500

Scales. Metric scales are available:

Staedtler-Mars Model 987-18-1
Alvin Model 117 PM
Charvoz Model 30-1261

Contact your local graphic arts supply store to order.

NOTE: These metric scales are made overseas, as are most inch size Architect scales available today.

03 Rebar

Atlantic Steel GA, can make A615M bar.
R.S. Mellum 404-897-4505

Birmingham Steel AL, produces metric bar in their Salmon Bay Steel subsidiary, and can produce it in their IL, AL, and MS facilities.
Robert Wilson, H.A. Hilton 205-985-9290

Salmon Bay Steel stocks rebar in 10-35 mm. Minimum order is about 20 Mg, or one truckload, which can consist of different sizes, and can be shipped anywhere in the country. Facility ships rebar overseas regularly.
Chuck James, Paul Cmorey 800-677-1012

Cascade Steel OR, currently makes 10-35 mm. 45 and 55 mm might require some lead time. When sizes are in stock, minimum order is about 20 Mg, or one truckload, which can be mixed sizes.
Glen Peterson 503-472-4181 x 3307
Dennis Lauber 503-434-3275

Florida Steel FL, can produce A615M bar.
Has production in FL, NC, and TN.
Don Ballard, Don Haney 813- 251- 8811

Marion Steel OH, can make A615M but is not able to make 45 and 55 mm.
Gerry Lehrke, Michael Johnson 614-383-4011

New Jersey Steel NJ, has made metric rebar, can make A615M rebar.
Gary Giovannetti, Elaine Skiba 908-721-6600

North Star Steel MN, has made metric before, can produce A615M sizes in their MN and IA facilities.
Michael Hanson 612-688-1719
Wm Pepper 612-731-5644

Nucor Steel UT, can make A615M rebar.
R. Wayne Jones 801-458-3961

Parker Steel OH, can supply A615M rebar. Plans are being made to provide stock to handle any size order.
Paul Goldner 800-333-4140

Thomas Steel IL, has made metric bar, can make A615M. Edward Koper Jerry Wenzel 708-257-7701

04 Block / CMU

Many firms can supply hard metric block. Unless otherwise stated, there will generally be lead time and cost impact to this product. See GSA national policy on this issue.

Adams Products can make metric block. Several hundred block orders are acceptable.

Adams Products NC, Buddy Ray 919-467-2218
Adams Products NC, Cheryl Gaw 919-488-4120
Adams Products NC, Betty Hughes 919-523-5136

Amcor Block UT, can make metric block.
Gayland Smith 801-295-5470

Basalite CA, can supply. Jim Mayer 916-678-1901

Betco Block is supplying metric block to GSA. Minimum order is 150 m2. Current project Betco is supplying is using about 1600 m2 (20,000 block)

Betco Block MD, Scott Harper 301-654-2312
Betco Block NY, Steve Nagel 518-756-2125
Betco Block VA, Robert Carmody 703-591-2770

Buehner Block UT, can supply the metric block.
Ron Hoffmann Kent Mortensen 801-467-5456

Burns and Russell MD, Michelle McVey 800-638-3188

Clarkes Block GA, can supply.
L.E. Wells 912-234-3436

Colorado Concrete Mfg CO, can supply metric block.
Karl Dolder Thor Kaumeyer 719-390-5477

Concrete Mold Components CA, can supply molds.
Maurice Alhadeff 213-636-7534

Dagostino Building Blocks NY
Ken Dagostino 518-374-3116

Elco PA, can produce metric block. Several hundred block orders acceptable. Walter Albright 717-274-3661

Featherlight Building Products TX, can produce metric block. Wade Albritton H.V. Moss 512-472-2424

Fizzano Masonry PA, has indicated ability to supply for VA project in Philadelphia. 215-833-1100

Goria Enterprises NC, can make metric block.
Ken Mayo 919-375-5821

Grand Blanc Cement MI, can supply metric block.
Can supply metric molds, all shapes.
Michael Hicks Ron Hunt 800-875-7500

Hagerstown Block MD 301-733-3510

E.P. Henry NJ, can supply hard metric block.
Stephen Reale Mariane Anzaldo 609-845-6200

Adolph Jandris MA, Tony Raila 508-632-0089

Jewell Concrete Products TX, can make metric block.
Several hundred block orders are acceptable.
Walter Grisham 817-772-3440 Tom Call 903-592-0752

Marquart Block IA, can supply hard metric block.
John Thiele Scott Shimp 319-233-8421

Miller Materials MO, can make metric block.
Several hundred block orders are acceptable.
Charles Kreutzer 816-444-2244

Mission Masonry CO, supplied metric block to the GSA Denver facility. 303-841-6089

Phoenix Inc MD
John Cissel Don Bowers 301-698-4010

Plasticrete CT, Joe Rescigno, 800-243-6934

Proudfoot Corp CT, has made metric molds in the past, can supply metric sizes.
Michael Thompson / James Loseth 203-459-0031

Reading Rock Inc OH Stan Bass 513-874-2345

Sherman Int'l AL, Dannie Rodgers 205-252-6900

Southern Brick & Block VA, Ron Peters 804-353-6681

Superlite Block AZ, can make. Several hundred block orders acceptable. John Graves 602-352-3500

Trenwyth Industries PA, makes many metric block sizes.
Linda Adcock 800-233-1924

Tricon Enterprises MA
Monica Maracaccio 508-697-6112

04 Block / Glass

Pittsburgh Corning PA, makes metric glass block.
Several patterns. 190 x 190 mm (80 or 100 thick)
Robert McMarlin 412-327-6100

05 Anchor Bolts

These firms can provide metric anchor bolts, threaded rod, and similar material.

Archer Engineering IL, no minimum quantity.
Ron Lanie 312-247-3501

Atwood Industries OH, no minimum order. Premium on smaller quantities.
Jeff Mueller, James Mraz 800-362-2059

Fansteel Mfg IA, lists metric threads can be obtained on their anchor bolt products.
800-394-7091

High Point Fasteners NJ, no minimum quantity.
Ted Brace 201-293-3411

Hilti OK, offers their HSL metric expansion anchors in M8, M10, M12, M16, M20, and M24.
XXX Dick Wollmenschauzser 800-879-6000

Kenneth Lilly Fasteners DE, no minimum quantity.
Gary Lilly, Roland Sharp 800-433-1815

Midstate Bolt and Screw MI, no minimum quantity.
Herb Sommers, Kevin Bloss 800-482-0867

O'Brien Iron Works CA, no minimum quantity.
Richard Schulba, Richard Kotalik 510-685-5300

Piping Technology TX, \$ 35 minimum order.
Marion McKnight, Aundrela Durham 713-731-0030

R and R Engineering IN, minimum 500 pieces.
Mike Melott, Ralph Amos 317-536-2263

Richmond Screw Anchor TX, no minimum order, premium on orders of 100 bolts or less.
Leroy Caldwell 817-589-2091

Stanley Industries MI, can supply metric anchor bolts and threaded rod. Mr. Cash 800-253-BOLT

Steel Products/Massillon OH, minimum \$ 50 order.
Colin Petrovich Dan Alvarez 800-874-2658

Sullivan Bolt CA, can make metric anchor bolts.
800-423-4287

Threadline Products NC, no minimum quantity.
Lenore Lemmond, Larry Stanley 704-523-5870

Vulcan Threaded Products AL, minimum order is 10 bolts. Jim Murdock 800-633-3432

Wayne Bolt MI, no minimum quantity.
Joe or Mike Wojcik 800-521-2207

05 Nuts

These firms can supply nuts for anchor bolts and common construction fasteners.

Century AL, can supply metric nuts. \$ 50 minimum order. Lynda Oakley 205-772-7300

Coloc TX, can makes up to M60 nuts. Many grades. \$ 50 minimum order.
Dick Ingram 903-848-8411

Fasteners and Metal Products MA, can supply metric nuts. No minimum. Tom Hatzis 617-489-0414

Midwest Bolt and Supply MO, can supply metric nuts. \$ 25 minimum. Bill Thate 816-842-7880

North Texas Bolt & Nut TX, a distributor, can supply metric nuts, \$ 35 minimum order.
John Ricard 214-647-0608

Quality Bolt LA, can provide orders in the \$ 200-300 range. Pat McGrail 504-465-0297

Samson Industries AZ, can supply. \$ 25 minimum. Brian Saxton Christine Gruice 602-581-8082

05 Steel Plate

Metric steel plate is available from US mfrs, and is being specified in hard metric on our projects.

Most firms indicated metric plate is usually not stocked, and would require some additional lead time. Many of these firms could also be consulted for hard metric sheet metal purchase.

Many firms indicated however that no order would be too small to supply, such as an order for 5 or 10 base plates, however premiums would apply to smaller orders. Many grades can be supplied.

Many of these firms also fabricate.

We can provide data on what standard sizes of plate are being specified in government projects.

Sample firms that stock metric thickness plate, or are able to supply or produce it:

Accro-Met NC, can supply in 6-150 mm.
Steve Ferguson 800-543-4755

Alloy and Carbon Steel Co NJ, no minimum quantity.
Gail Ferranti 908-613-9150

Concord Steel OH, no minimum order.
Paul Vesey 216-372-2030

Excel Bridge Mfg CA, can obtain steel plate and fabricate products in any metric dimension.
Craig Vasquez 310-944-0701

Gulf States Steel AL, has made metric plate before. No minimum order. Lester Bridges 800-423-0004

Hardox Corp PA, no minimum order, but small orders would have longer lead times.
Tom Sullivan 800-666-0092

High Steel Structures PA, one of the largest heavy plate steel fabricators in the nation, can provide plate, bearings, structural shape lengths and geometries, bolts, and other items, fabricated in hard metric.
No minimum order. Doug Winner 717-293-4099

Hub Inc. Energy and Process Div GA, can handle small and large orders, has full cutting and milling capability.
Marc Capallo 404-723-7531

Johnston and Jennings IL, has supplied metric plate before, can supply maximum 600 mm thickness. No

minimum order. John Violet 708-757-5375

Leeco Steel Products IL, stocks some A572M metric plate. Can supply any size/thickness in A572M or other grades.

Sales Department 800-621-4366

Metalmart CA, has supplied metric plate. Stocks some, can supply many other thicknesses.
Hank Morin 800-888-7766

Mills Alloy Steel OH, can supply metric plate.
Dave Gilbert 800-326-6455

Parker Steel OH, can supply metric plate and many other structural shapes, as well as bar and sheet stock. Paul Goldner 800-383-4140

Pioneer Steel MI, no minimum order. Facilities in AL, MI, and TN. Rob Beves 800-999-9440

Skorr Steel NY, stainless steel plate only.
Joe Piela 718-386-9577

Stainless Specialties TX, no minimum quantity. Supplies carbon, stainless and nickel alloy plate.
Has supplied metric plate before.
Robert Caudillo 713-840-0444

Universal Fabricators WV, can supply metric plate.
Mike O'Connor 800-394-1385

United States Steel can provide a chart showing their standard metric plate thicknesses (6-160 mm). They indicate their mill prices are generally the same as their prices for equivalent english sizes.

05 Structural Bolts

Many firms can produce A325M/M164M, and A490M/M253M bolts. Some can make ASTM A394M, galvanized metric transmission tower bolts.

Metric bolts may now be utilized on all projects.

Some firms indicated they could supply metric bolts at small quantities, but premiums primarily related to set up costs, would be associated.

See also bolt data in Road Design Data / Louisiana.

Aetna Screw Products IL, can make A325M and A490M. Frank or Joe Valerio 708-647-9555

Atwood Industries OH, can supply A325M and A490M, as well as other metric bolts.
James Mraz, Jeff Mueller 800-362-2059

Bennett Bolt Works NY, \$ 100 minimum order.
Ron Merrill NY 315-689-3981
Vince Ruggerio OH 216-979-9813

Cold Heading Co MI, can make metric bolts.
Bill Deason Tom Paull 313-923-7800

CWR Manufacturing NY
Fay Cluett 315-437-1030

Detroit Heading MI, can also make A394M.
Roger Palmer, Kevin Stanisz 313-925-8138

Haydon Bolts PA 215-537-8700
Richard Giusti 215-537-8700

Holo-Chrome CT
Skip Gallo

Huck Int'l TX, makes A325M and A490M product.
Larry Chipman, Chuck Schultz 800-388-4825

Kenneth Lilly Fasteners DE, can supply A325M and A490M. Gary Lilly, Roland Sharp 800-433-1815

Lake Erie Screw OH
Steve Vass 216-521-1800

Metric and Multistandard Components NY, can supply A325M and A490M bolts. Also supplies other metric bolts. Roger Stilman 800-431-2792

Mid-West Fabricating OH
Vaughn Doss 614-969-4411

National Bolt NY, minimum order is 500 bolts.
M.D. Strauss 800-992-6587

Nucor Fastener Div IN, minimum order is one keg per size. Cecil Couch, Peter Kasper 800-955-6826

Ohio Rod Products IN, states that metric is available upon request. 812-689-6565

Steel Products/Massillon OH, \$1000 minimum order.
Colin Petrovich, Dan Alvarez 800-874-2658

Sullivan Bolt CA, is able to make metric bolts.
800-423-4287

United Steel and Fasteners IL, no minimum quantity. Premium on smaller orders.
Perri Guerino, Bob Fiorio 708-250-0900

Wayne Bolt MI, no minimum quantity.
Joe or Mike Wojcik 800-521-2207

06 Lumber

Oregon Overseas Timber OR

currently manufactures metric lumber sizes for export, thickness 27-76 mm, width 75-280 mm
Jim Curran 503-347-4419

Vanport Mfg OR

90% of production is in hard metric for Japanese and other export markets.
Thicknesses 27-120 mm Widths 45-360 mm
Wayne Geist 503-663-4466

06 Plywood

Metric plywood can now be used for items like housing, barracks, sheathing or formwork applications.

Amer-Ply NJ, can supply metric sheets. No minimum order quantity. Mr. Matthew 908-352-8111

Boise-Cascade ID, has made metric before, can supply metric. Jan Blechschmidt 206-572-8300

Champion International WA, makes metric sheet sizes and thicknesses. Metric available for underlayment, sheathing, and sanded products. Metric concrete form panels can be ordered. Minimum order is 1 truckload.
Jim DiStefano 206-572-8300 (form panels)
Steve Williams 206-572-8300 (plywood, western)
Jim Clark, TN 901-731-4550 (plywood, southern)

Furman Lumber MA, can supply metric from their usual suppliers. Chris Hemingway 508-670-3800
Offices: CT FL GA MD NJ NY PA TX VA

Multnomah OR, can supply 50-100 piece orders.
Paul Brooks Anne Snyder 503-297-4738

Murphy Plywood OR, can make metric plywood.
John Murphy Mark Gryzniec 503-459-3225

Oregon Strand Board OR, can make metric engineering panels, similar to plywood, at no additional cost. Minimum order is one truckload.
Joe Maliszewski 503-466-5177

Potlatch WA, has exported metric, can make metric sizes. C.D. Whitney / Mac Ryerse 509-328-0930

Roseburg Forest Products OR, makes 6-19 mm thick plywood, can make metric sheets. Makes other metric wood building products. Min. order is 1 truckload.
Dave Adams / Kevin Barry 503-679-3311

Stone Forest Industries, OR, currently produces both metric dimensional and thickness plywood. This firm could produce about two pressloads minimum order (about 60 sheets) but premiums would apply to small orders of this size.

Lain Osborn Tom Clow 800-541-6906

Vancouver Standard

has made metric sizes, can make metric sizes. Generally makes AC and higher grade.
Ken Trimbell / Bill Sparks 800-367-0038

Other firms indicated on the telephone they were able to make metric plywood, but we did not receive detailed data from them in time for publication.

07 Curtainwalls

These are obtainable in hard metric. This means panel length and width can be any size. Panel extrusions may be hard to change, and may need to be specified in soft metric.

Howard Industries, FL, a major windowall mfr, has done foreign work, can make metric sizes.
Bob Voigt or Joe Sixto 305-888-1521

Profile Systems, MO, subsidiary of the Maune Company, can make hard metric sizes.
Grant Maune, 800-962-8100

Kalwell Corporation, NH, a major curtainwall producer, can make hard metric sizes.
Bruce Keller, 800-258-9777

Kawneer Company, GA, a major manufacturer, has been making metric for overseas for years, and can make any metric size.
Enrique Morales, Int'l Sales Mgr, 703-433-2711
Edward Bugg, Asst Engrg Mgr, 703-433-2711

07 Insulation

Several firms indicated ability to fabricate insulation board in hard metric sizes. Our projects are now specifying these.

08 Doors / Metal

Acme Steel Door NY
Jack Teich 718-384-7800

Allied Steel Products FL, no minimum.
Bill Desin 305-624-3333

American Steel Products NY
can make any size metric door.
Hank, 516-293-7100

Amweld Building Products OH
Has made metric before, can make metric sizes.
Mike Scott or Fred Bloom Jr 216-527-4385

Ceco Door IL, a major mfr, can make any hard metric size. Norb Bruzan, 312-242-2000

Duolock OR, major aluminum products mfr, can make any metric size. Clem Grant 800-678-0566

SW Fleming CA MA PA SC
William Strong 800-263-7515

Howard Industries FL, has made metric, can make metric sizes. Bob Voigt or Joe Sixto 305-888-1521

Republic Builders Products TN
Jim Jackson 901-352-3383

Stanley Door Systems MI
Mark Goldstein 313-528-1400

Steelcraft Mfg Co OH, no minimum order.
Makes metric sizes now, exports to many countries.
Bill Ball Claud Frederick 513-745-6400

Tex-Steel Corp TX, no minimum order.
George Maldonado 512-423-0912

08 Doors / Wood

Many other door manufacturers indicated ability to supply metric doors but did not respond with detailed information prior to publication.

California Millworks CA, \$ 10,000 minimum.
Dave Gerken 805-294-2345

Eagle Plywood and Door Mfr NJ, no minimum.
Tony Schifano 908-769-7650

Marlite OH, can produce.
Donald Sweitzer 216-343-6621

Michigan Birch Door MI, minimum order is 6 doors.
Roger Eger 313-949-2020

Mohawk Flush Doors PA, no minimum.
Don Enigk 717-473-3557

Vancouver Door WA
Gary Geppert 206-845-9581

08 Windows

Alenco Commercial Group TX, major window mfr, can make metric sizes. Harold Chilton 409-823-6557

Andersen Windows Commercial Group MN, exports, has SI literature available. Craig Johnson 612-439-5150

Caradco IL, can make any size metric window. Roy Szyhowski 217-893-4444

Desco Company Desmet SD, can produce metric sizes. Cindy Albrecht, 605-854-9126

Marmet Corporation WI, can make any size metric window. Brent Schepp 715-845-5242

Marvin Windows MN, has made and can make metric sizes. Dan McKinnon 218-386-1430

Optimum Windows, Bronx NY, can produce hard metric sizes. Candido Perez, 212-991-0700

Peerless Commercial Window Division MO, can make any metric size. Tony Grossi 913-432-2232

Pella Windows IA, can make any size metric window. Cheryl Waits 515-628-1000

09 Carpet

Collins and Aikman, is able to supply metric size tiles.

Interface GA, has dies to supply metric tiles. No minimum, but premiums on orders from 1 to 100 m2 orders. Scott Landa Kathy Kerby 800-336-0225

Milliken GA, has dies and makes metric size tiles.

Shaw PA, makes 500 x 500 and 600 x 600 for overseas clients. Can supply to US for 25 m2 minimum orders. David Vita 800-424-7429 x 8459
Russ Riehm x 2064

09 Ceiling Systems

Armstrong World Industries PA, makes metric. Usually no added cost or lead time for metric sizes. Dan Kennard 717 396 x 2684 Deb Kantner x 3045

Capaul Architectural Acoustics IL, can make metric sizes. Tom Stanton (distributor) 410-234-0010

Celotex Corporation FL, a major tile mfr, offers an entire product line of hard metric sizes. George Mitchell 813-873-4027

Chicago Metallic Corp IL, makes metric grids. Craig Trotier 800-323-7164

National Rolling Mills PA, makes metric sizes. Rich Mattioni 215-644-6700

Steel Ceilings OH, can make metric perforated and unperforated accoustical metal ceiling panels in steel, aluminum, and stainless. Lou Heil 614-622-4655

USG Interiors IL, makes metric sizes. William Nelson 312-606-5358
David Vanosdall 312-606-3804

09 Drywall

Celotex FL, George Mitchell 813-873-4027

Centex American Gypsum NM, minimum order is generally one truckload (~2000 m2) dependent on job location and production status at time of order. Lex Dominey 800-545-6302

Domtar Gypsum MI, has made, and will supply in less than one truckload increments if premium is paid. George Shortreed Jim Hanser 313-930-4700

Georgia Pacific GA
Bronwyn Dawkins 404-521-4000

James Hardie Gypsum NV, can supply in 2000 m2 minimum orders. Todd Thomas 310-787-6950
Alex Beaman 800-995-0950 x210

National Gypsum NC, can make, has not yet fixed their minimum order. Kurt Withrock 704-365-7475
David Drummond 704-364-7474

Temple Inland TX, can make. Jim Rush 800-231-6060

USG Interiors IL, can make. See USG names above.

09 Floor Tile

Burke CA, makes 500 x 500. 408-297-3500
Freudenberg MA, makes 1000, 500, 250 mm tiles. Joe King 508-689-0530
Gerbert PA, makes 300 x 300. 717-299-5035
Roppe OH, makes 500 tile. 800-537-9527

10 Access Floor

Following firms make 600 x 600 access floor.

C-TEC Inc MI, Don Heeney 616-243-2211

Interstitial Systems IL, Bill Collier 708-691-8600

Tate Access Floors MD, Lida Poole, Victor Sainato 410-799-4200

USG Interiors / Donn IL

William Nelson 312-606-5358

David Vanosdall 312-606-3804

Interface GA, commonly known for carpet, also makes access floor domestically. Only size is 500 x 500. Heights are lower than traditional heights, and are intended for wire management applications.

Lew Engle Peter LePage 800-336-0225

14 Elevators

A recent elevator project bid, requiring submittals and construction in metric, was bid by several well known producers. Project is now in construction.

The ability of US producers to provide drawings and data in metric is essentially unanimous. We have discussed metrication with both US firms and many of their Canadian operations, and find consistent practice.

Dover NC, can provide metric drawings for US work.

Montgomery IL, has done metric for overseas, most Canada jobs are metric, can do metric for US work.

Otis Elevator CT, can do US work in metric. New designs are often hard metric and have started to use hard metric fasteners.

Schindler NJ, can provide drawings in metric for elevator, escalator, and moving walk equipment. Escalator products made in NC are produced in metric.

15 Air Diffusers and Grilles

Acutherm CA, mfr of VAV air distribution devices, can make metric sizes. Jim Kline 510-428-1064

Aireguide FL, a large air products mfr, can make 80-90 % of its products in metric sizes.
Daryl Gray 305-888-1631

Carnes WI, a large mfr, often makes metric sizes. Dick Laughlin 608-845-6411

Donco Air Products IA, can make light troffer, slot, and lay-in diffusers up to 1500 mm long.
Ron Jansen / Marc Vanedgrift 515-488-2211

Duralast LA, can make its diffuser product in 600 x 600. Ron Vinson (distributor) 504-837-2346

J & J Register TX, can make hard sizes.
Chris Smith 915-852-9111

Juniper Industries NY, has made, and can make metric size diffusers and grilles.
Steve Liebermann 718-326-2546

Krueger Inc AZ, can make metric sizes.
Steve Bowser 602-622-7601

Reliable Metal Products AL, part of Hart & Cooley, can make 90 % of its products in metric sizes.
John Bowers 205-684-3621

Rock Island Register IL, can make its diffuser in 600 x 600. John Howarth 309-788-5611

Sommerville Metalcraft IL, can produce metric grilles and diffusers. Paul Moehling 800-654-3124

Thermo Kinetics SC, can make metric grilles and diffusers. No extra cost. Terry Rutledge 803-277-8080

Titus Products TX, major mfr of grilles and diffuser products, indicates a number of products now available in metric sizes. Dave Loren 214-699-1030

Trane has begun to offer metric data on their VAV products.

15 Mechanical Equipment

Many major manufacturers of mechanical equipment already have metric literature on their products, are converting literature and product data to metric, or have committed to do so for US metric projects.

American Standard
Ansul Fire Protection
Aurora Pump
Baltimore Air Coil
Carrier Corporation
Central Sprinkler
Dunham-Bush
Hurst Boiler
ITT Bell Gossett
Landis and Gyr Powers
Liebert, current catalog has metric.
Loren Cook Company
Marley Cooling Tower
McQuay
Trane Company
York

16 Conductors

These firms either have made metric conductors before, or are able to make them.

Americable AR, produces mm² sizes, and can supply for US projects. (sizes 0.5 to 300 mm²)
Noubar Sarkissian 800-643-1516

American Flexible Conduit MA, has made metric before, can produce mm² sizes.
Glenn Stewart 800-225-8588

Kerite Company CT, can produce mm² sizes.
203-888-2591

Okonite Company NJ, can produce.
Jim Kushner 201-825-0300

Pacific Electricord CA, stocks some 0.75, 1, and 1.5 mm² product. Can produce other sizes.
Donna Tovey 310-532-6600

Pirelli Cable NJ, has made mm² sizes, can produce.
Tony Tremonte 800-845-8507

Rome Cable NY, has made mm² size, can produce.
Jan Visser 315-337-3000

Triangle Wire RI, has made mm² sizes, can produce.
Hilliard Huggins 401-729-5400

Southwire Company GA, has made mm² sizes, can produce. Sid Ticker 404-832-4242

16 Lighting Fixtures

We recommend that selection of fixtures be limited to the high volume, commonly used lay-in fixtures, since industry is concerned that the effort associated with converting all products to metric over a short period of time would be difficult, as tooling requires resources and time to construct.

Allan Lighting NJ, can supply lensed and parabolic 600 x 600 and 600 x 1200 fixtures. Electronic ballasts or other are available. 10-20 fixture orders are acceptable. Howard Komish 908-964-6885

ALP Lighting IL, which supplies louvers and lenses to many major US mfrs, can produce these products in any required metric size. ALP has supplied louvers to Germany and England in metric sizes. Don Michels 312-774-9550

American Fluorescent IL, can produce the 600 x 600 and 600 x 1200 fixtures. Electronic ballasts available. Parabolic and lensed available. Minimum order is about 500 fixtures. Gary Stabelfeldt 708-249-5970

Bieber Lighting Corporation CA, can make both 600 x 600 and 600 x 1200 hard metric fixtures. 18 cell parabolics, electronic ballasts, are available. Minimum order will be about 50 fixtures. Bob Bieber 800 243 2375 213-776-4744

C.W. Cole & Co CA, can make both 600 x 600 and 600 x 1200 hard metric light fixtures. Parabolic and lensed. Electronic ballasts are available. Minimum orders are about 20 fixtures. Frank Dayley Jose Lopez 818-443-2473

Day-O-Lite Manufacturing RI, can produce the 600 x 600 and 600 x 1200 fixtures. Electronic ballasts available, parabolic and lensed available. No minimum order quantity. Arthur Goldstein 401-467-8232

Hasco Electric Corp CT, can produce both the 600 x 600 and 600 x 1200 fixtures. Parabolic, lensed, and electronic ballasts available. Minimum order is about 20 fixtures. Anthony Varbaro 203-531-9400

H & H Fixture MO, can produce both the 600 x 600 and 600 x 1200 fixture. Electronic ballasts available. 5-10 fixture orders acceptable.

H.E. Williams MO, is currently making plans to be able to produce the hard metric fixtures. The firm is interested in hearing project inquiries, and may be able to supply these products in the near future. Ron Snyder Gary Fagg

Holcor IL, can produce 600 x 600 and 600 x 1200 fixtures. Electronic ballasts or other are available. 5-10 fixture orders acceptable. Mark Nelson Kathy Dykstra 312-376-9780

Holophane OH, can provide the 600 x 600 and 600 x 1200 fixtures. Parabolic or lensed available. Electronic ballasts available. Holophane has quoted hard metric inquiries before. Minimum order is probably about 100 fixtures. Bob Catone 614-345-9631

Lithonia GA, one of the largest US lay-in mfrs, produces hard metric fixtures in its SP, SP(air), Paramax, and Optimax products. West Coast: Marcus Cone 818-965-0711

Louisville Lamp Company KY, is able to supply both the 600 x 600 and 600 x 1200 fixture. Electronic ballasts, parabolics, lensed fixtures available. No minimum quantity. Mike Davidson 502-964-4094

Lumispec PA, can produce both 600 x 600 and 600 x 1200 hard metric fixtures. Parabolics, lensed, and electronic ballasts available. Minimum order is about 30 fixtures. Eric Papougenis 215-228-3830

Mark Lighting NJ, has made metric fixtures before, can supply both the 600 x 600 and 600 x 1200. Minimum order is about 50 fixtures. George Miller 201-939-0880

Midwest Chandelier KS, is now supplying hard metric 600 x 1200 parabolic and lensed fixtures to GSA projects. Prices are generally comparable to english size costs. Minimum order is 50 fixtures. Tom Lefkovitz Doug Pasternak 913-281-1100

Morlite Equipment PA 814-774-9631

Prudential Lighting CA, can make both the 600 x 600 and the 600 x 1200 fixture. Company only produces lensed products, such as lensed troffers. Parabolics are not offered. Electronic ballasts available. Minimum order about 75 fixtures. Tammy Swaim 213-746-0360

Simkar Lighting PA, has produced and can supply 600 x 600 and 600 x 1200 fixtures. Parabolics, electronic ballasts, are offered. Premiums on small orders such as 10-20 fixtures.

Robert McCully 215-831-7700

Solar Kinetics TX, is able to provide the 600 x 600 and 600 x 1200 fixtures. Electronic ballasts available.

Sandy McCrea 214-556-2376

USI / Columbia Lighting WA, the second largest fluorescent fixture producer in the country, often produces hard metric sizes, can supply 600 x 600 and 600 x 1200, and can make almost any size metric fixture. Lead times would not normally exceed 8-10 weeks. Mark Johnson Fred Smith 509-924-7000

Wellmade Metal Products CA, is able to produce both 600 x 600 and 600 x 1200 hard metric fixtures. Parabolics or lensed are available. Electronic ballasts are available. Minimum order is about 100 fixtures.

Bernie Shane 510-562-1878

Architectural / Cabinets

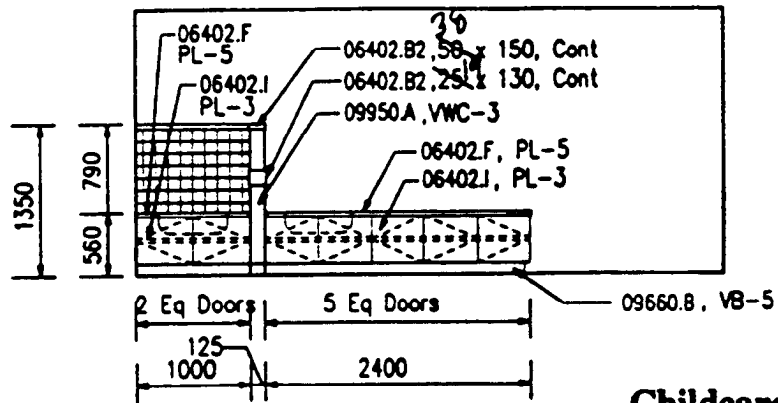
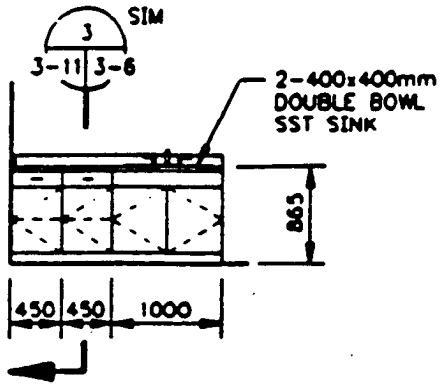

Note: See N1/A709 for tile pattern

Childcare Area

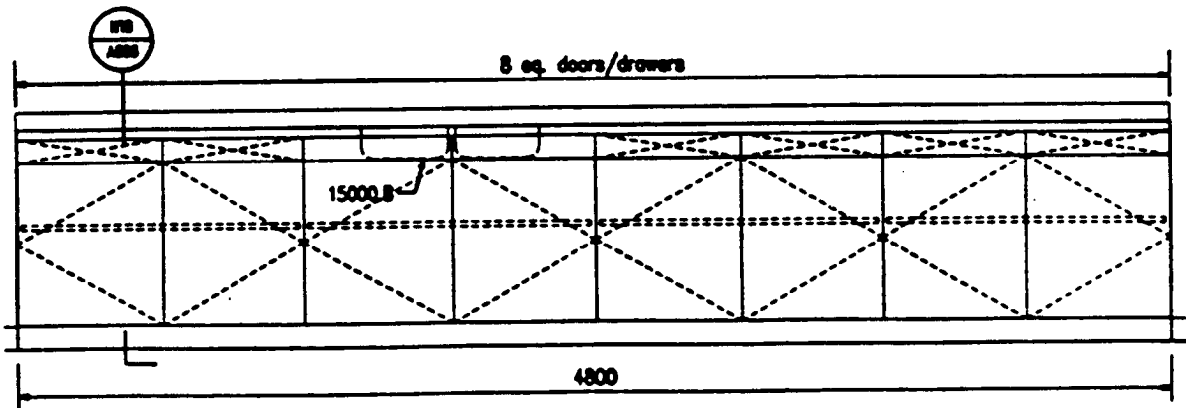

Architectural / Door

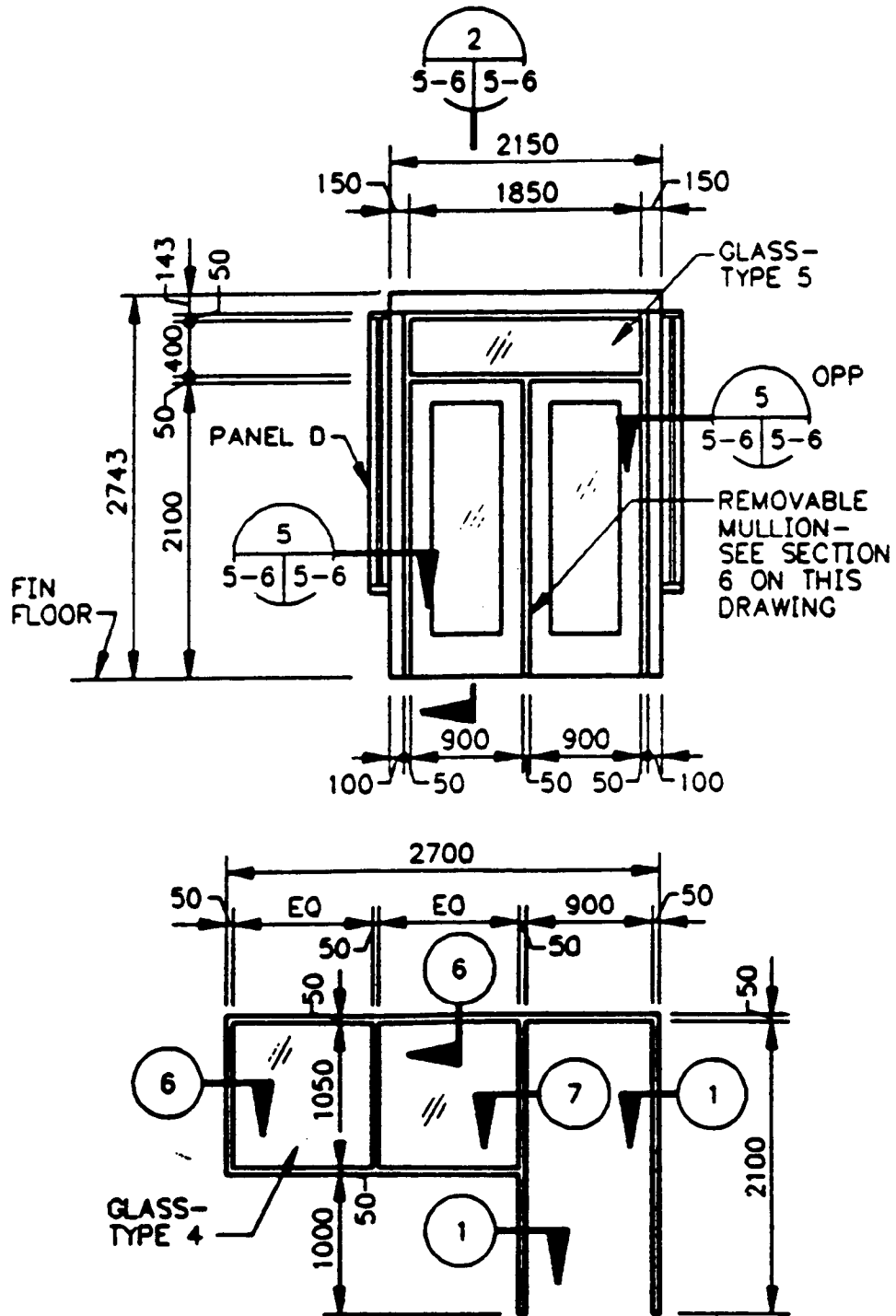

Above item shows hard metric doors installed in an existing location.

Architectural / Door Jamb

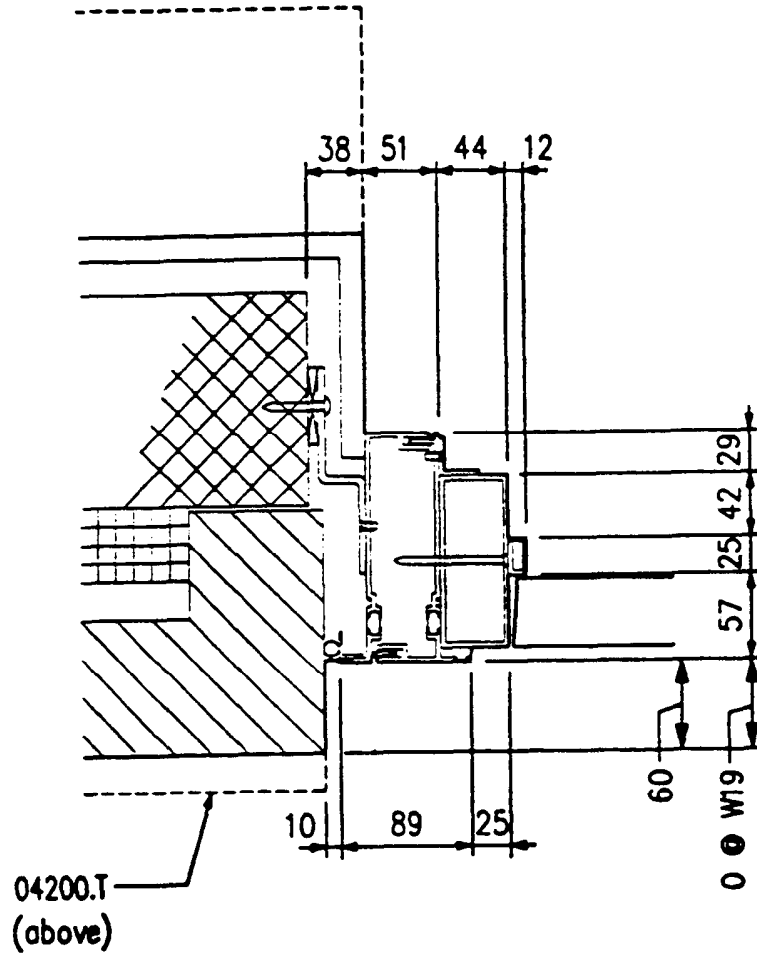

19 Door Jamb ● Low Wall

Architectural / Garage Detail

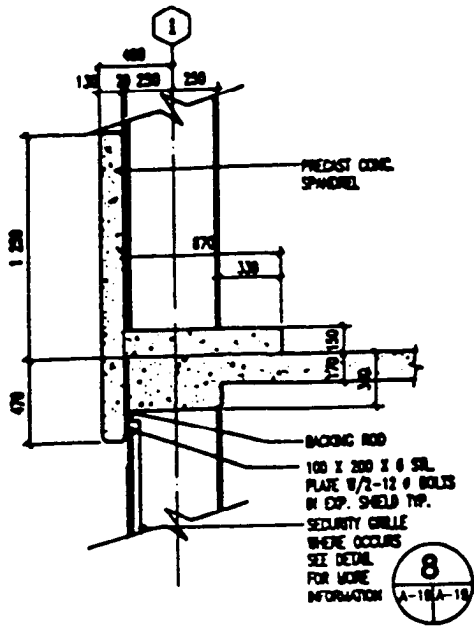

SECTION
SCALE: 1/32

(7)
A-3 A-18

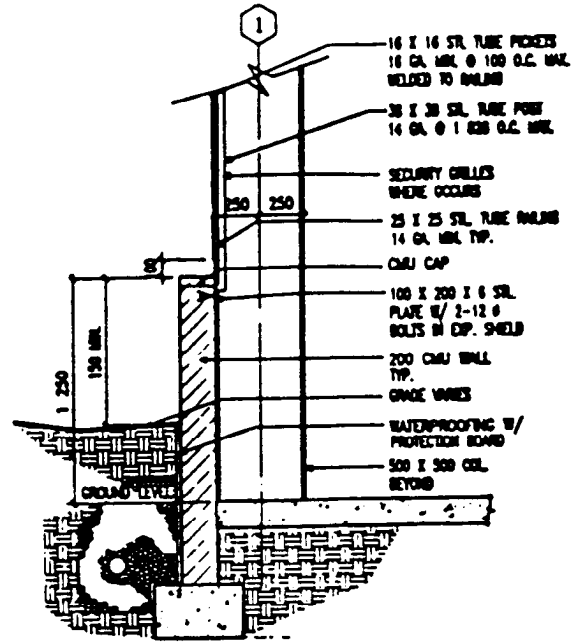

SECTION
SCALE: 1/32

(8)
A-3 A-18

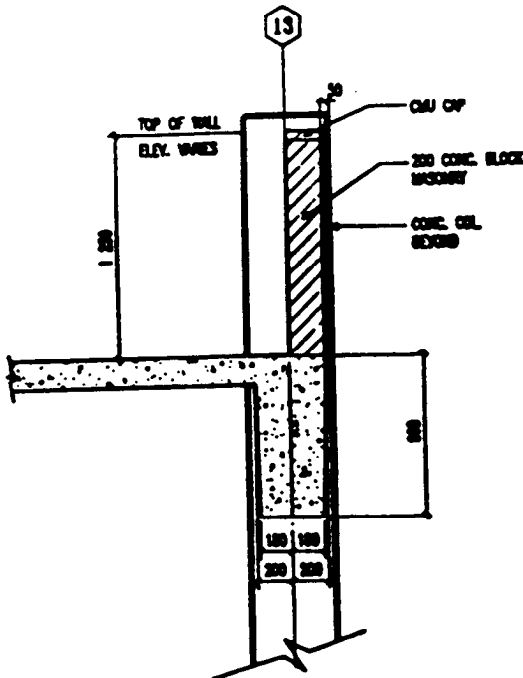

SECTION
SCALE: 1/32

(9)
A-4 A-20



 ALL NEW DRAWINGS MUST BE MADE
 IN ACCORDANCE WITH THE
 7-82.1

DEFENSE - CEETA
 PRINT SILVER, THICK
 PAPER STRAPLESS

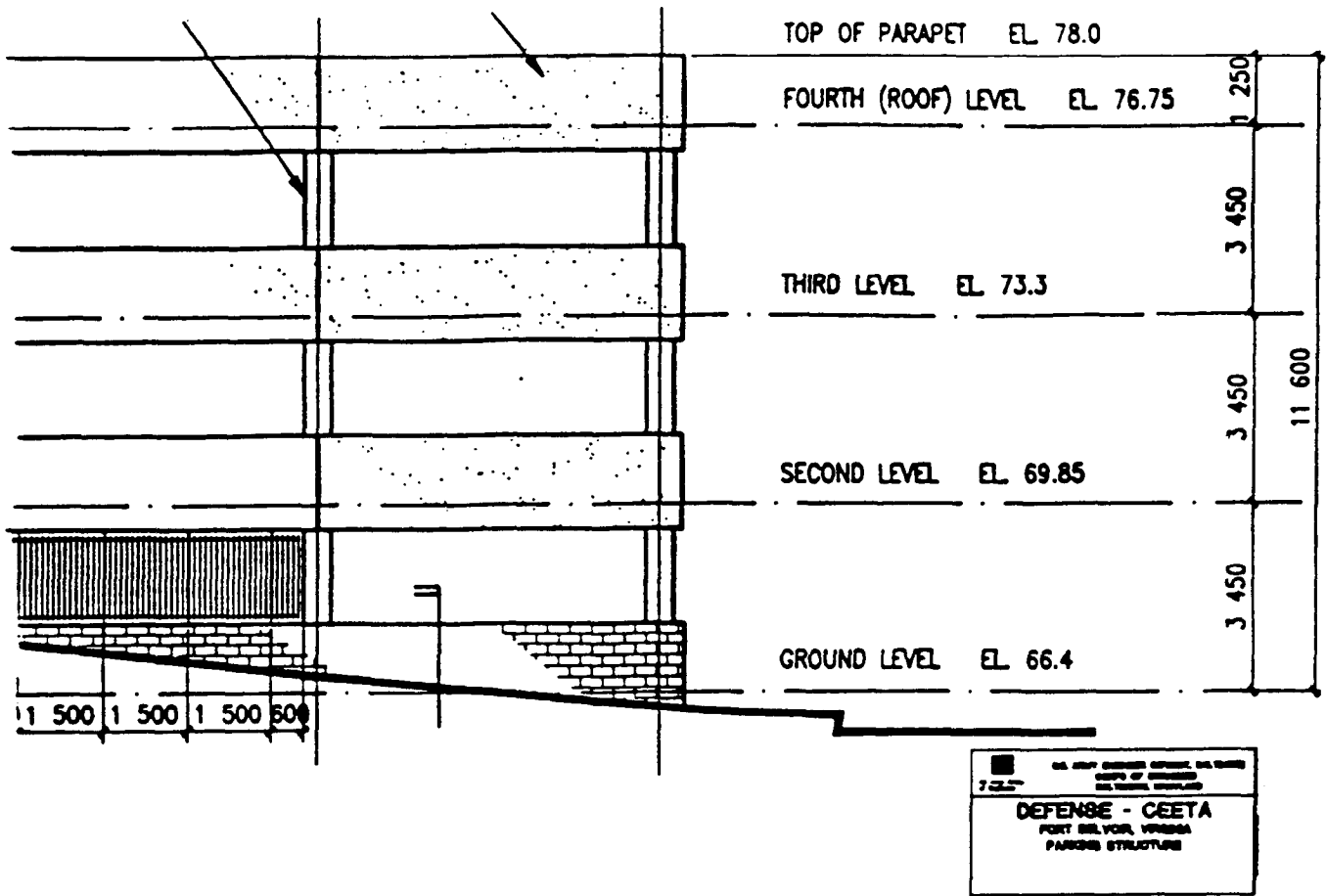
Architectural / Garage Elevation

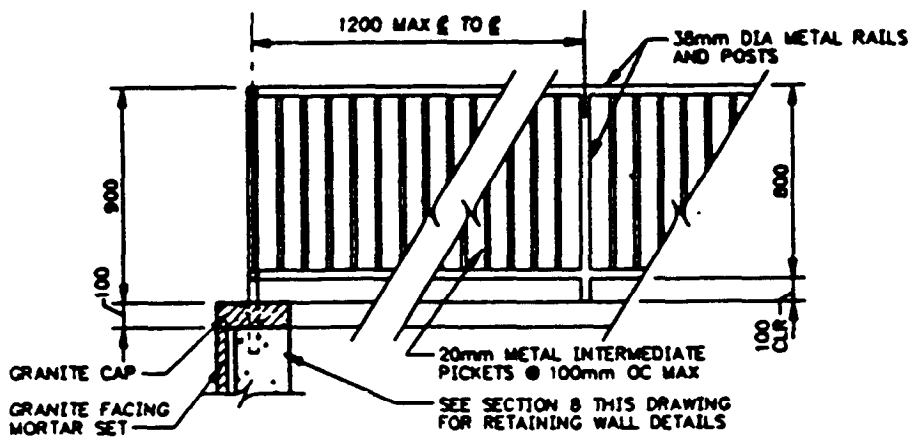

Architectural / Guardrail



TYP GUARD RAIL DETAIL

SCALE 1:20

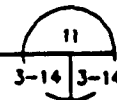

Architectural / Landscape Plan

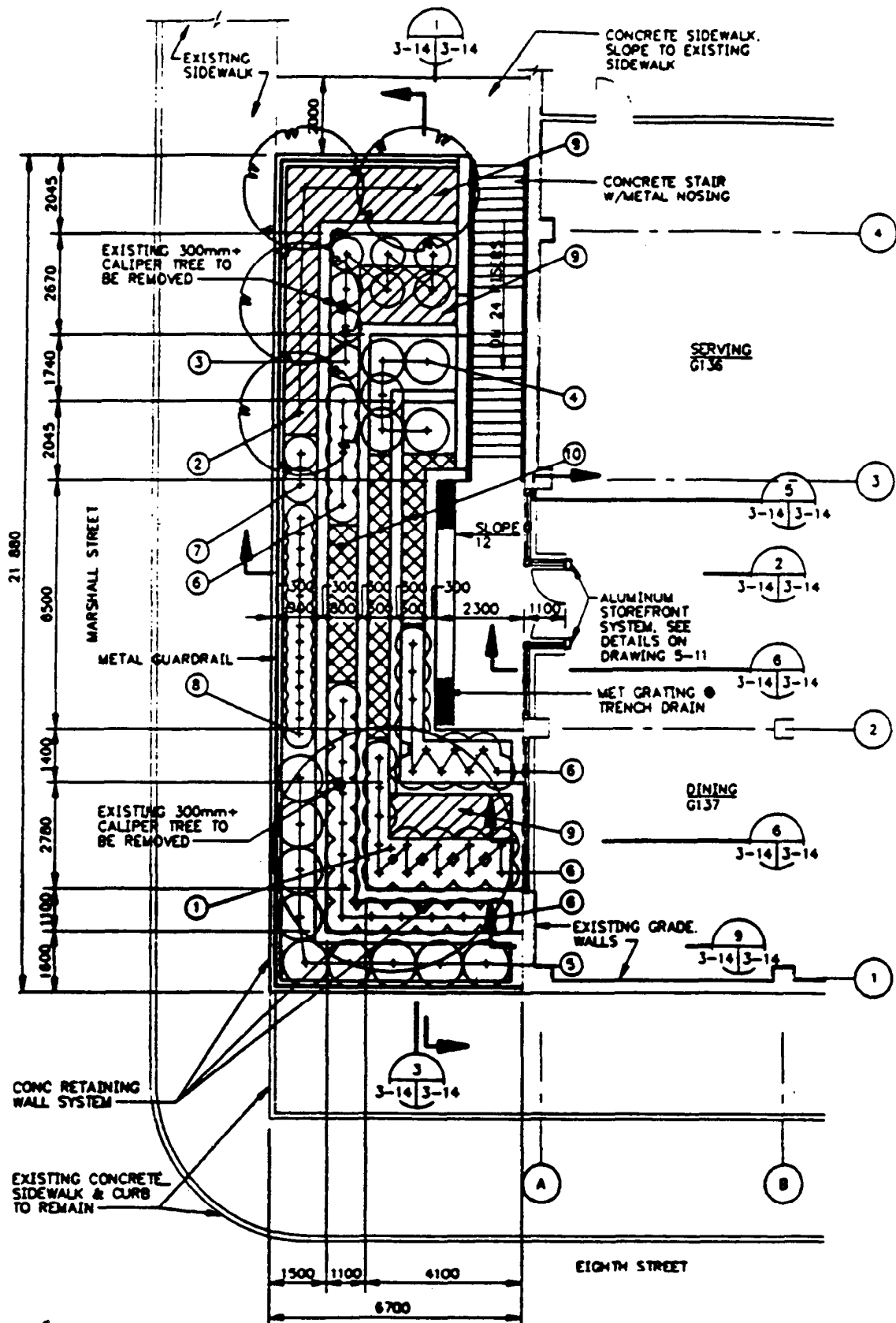

PLAN ● NEW ENTRANCE

SCALE 1:100

Architectural / Landscape Section

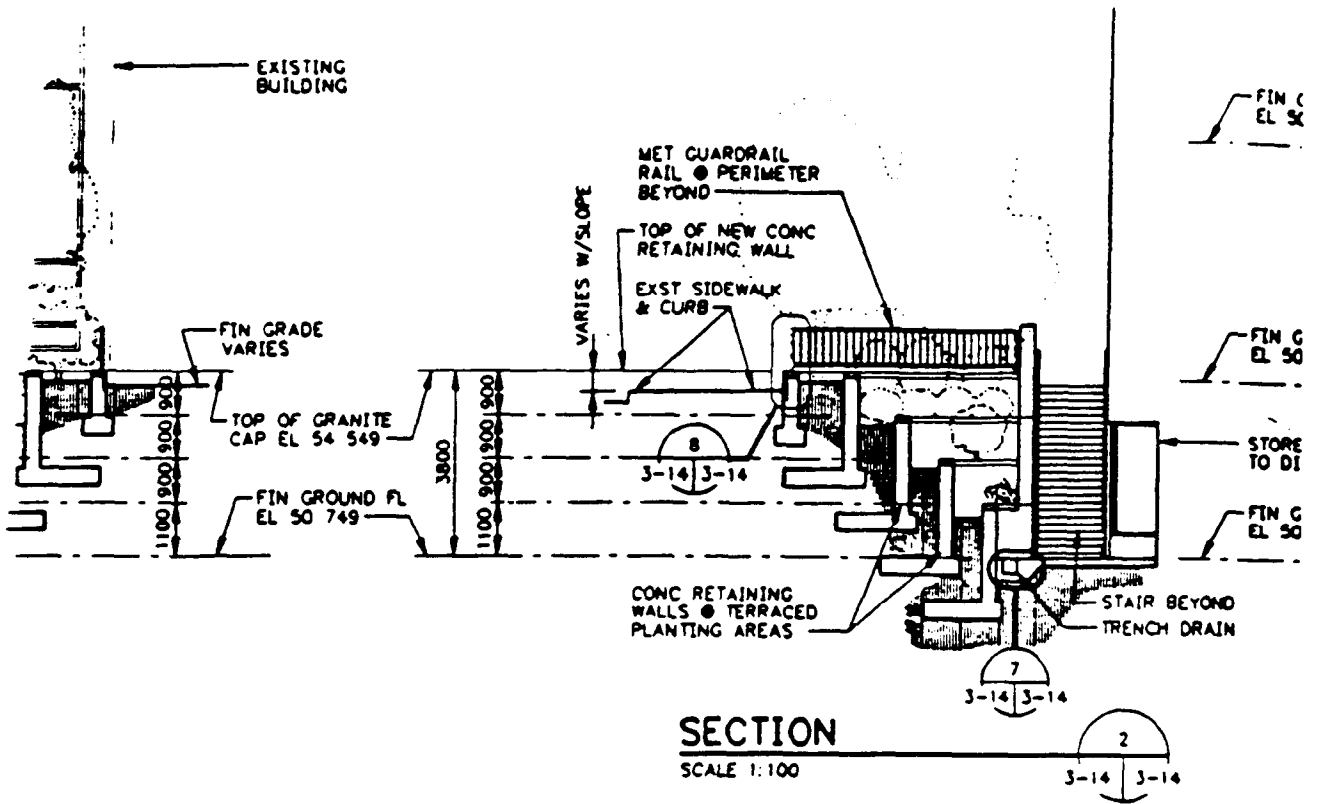

Architectural / Lintel

LINTEL SCHEDULE					
MARK	TYPE	MATERIAL	CLEAR OPENING	LENGTH	BEARING HEIGHT
L7		BLOCK & BRICK LINTELS OVER MECH. EQUIPMENT ROOM LOUVER 190 X 190 mm PRECAST CONC. BEAM W/ 4-#4 BARS GALV. LOOSE L102 X 102 X 9.5	1 800	2 200	3 050 AFF
L8		BLOCK LINTEL OVER DUCT PENETRATION IN MECH. EQUIP. ROOM. 190 X 190 mm PRECAST CONCRETE BEAM W/ 4-#4 BARS	850	1 250	3 000 AFF
L9		BLOCK LINTEL OVER DUCT PENETRATION IN MECH. EQUIP. ROOM. 190 X 190 mm PRECAST CONCRETE BEAM W/ 4-#4 BARS	800	1 200	3 000 AFF

Note: We would now specify hard metric rebar (ex, 15M bars).



Architectural / Lobby Renovation

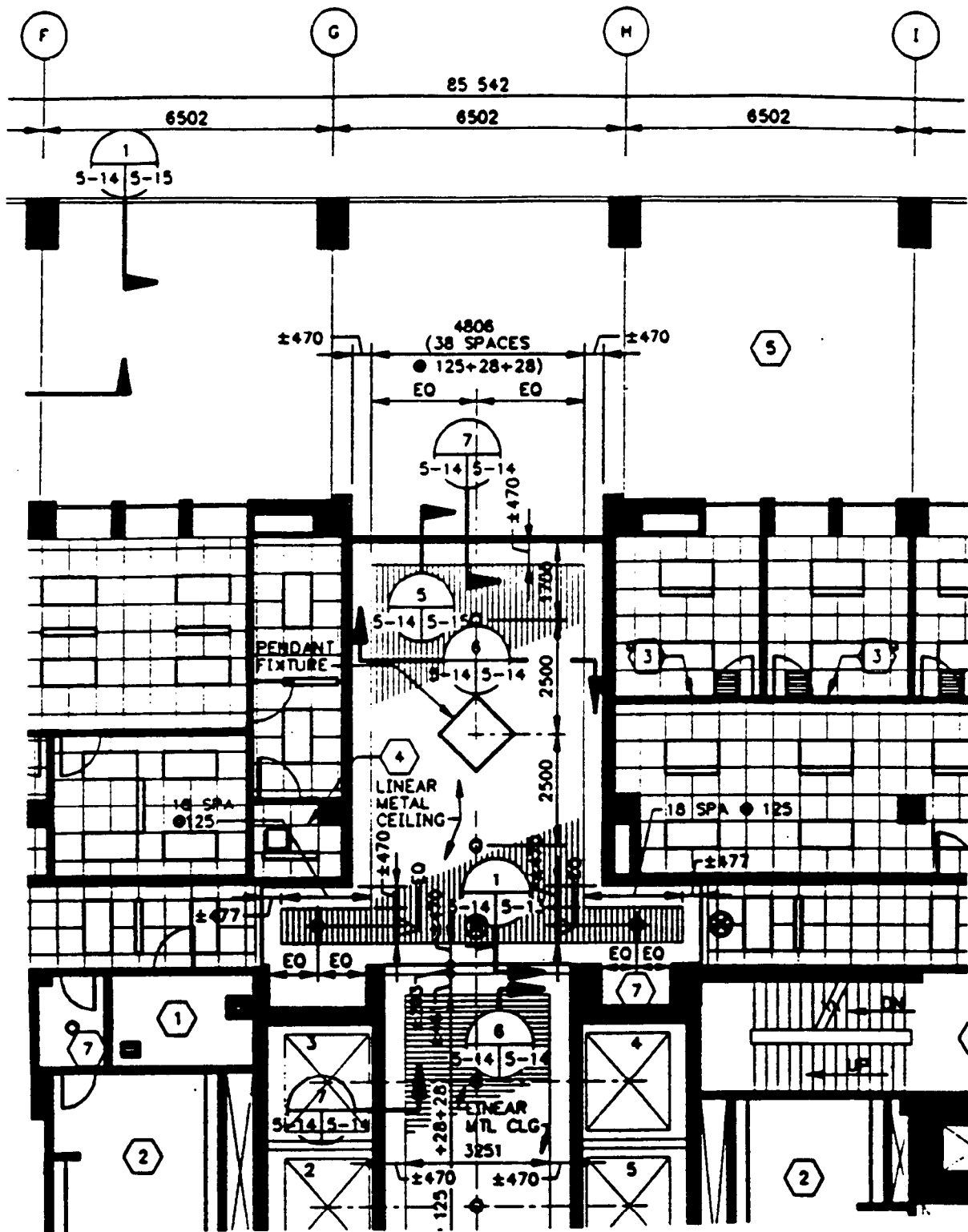

Shows use of rounded installation dimensions in lobby renovation. Shows 600 x 600 ceiling system in renovation. Column spacings are usually viewed as fixed dimensions except by the most aggressive project managers. (ex, 6502) Project in construction.

Architectural / Lobby Renovation

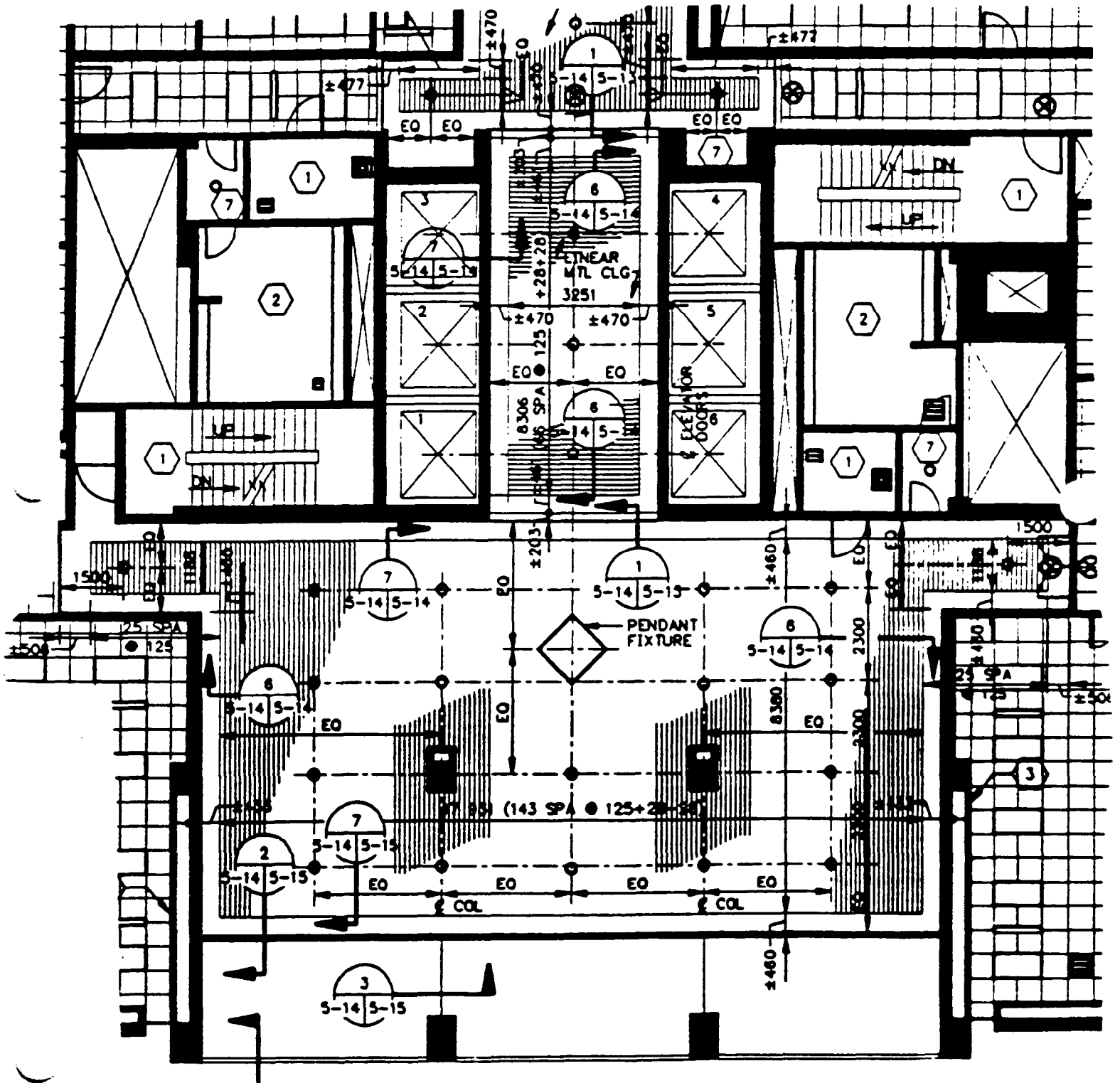

Architectural / Reflected Ceiling

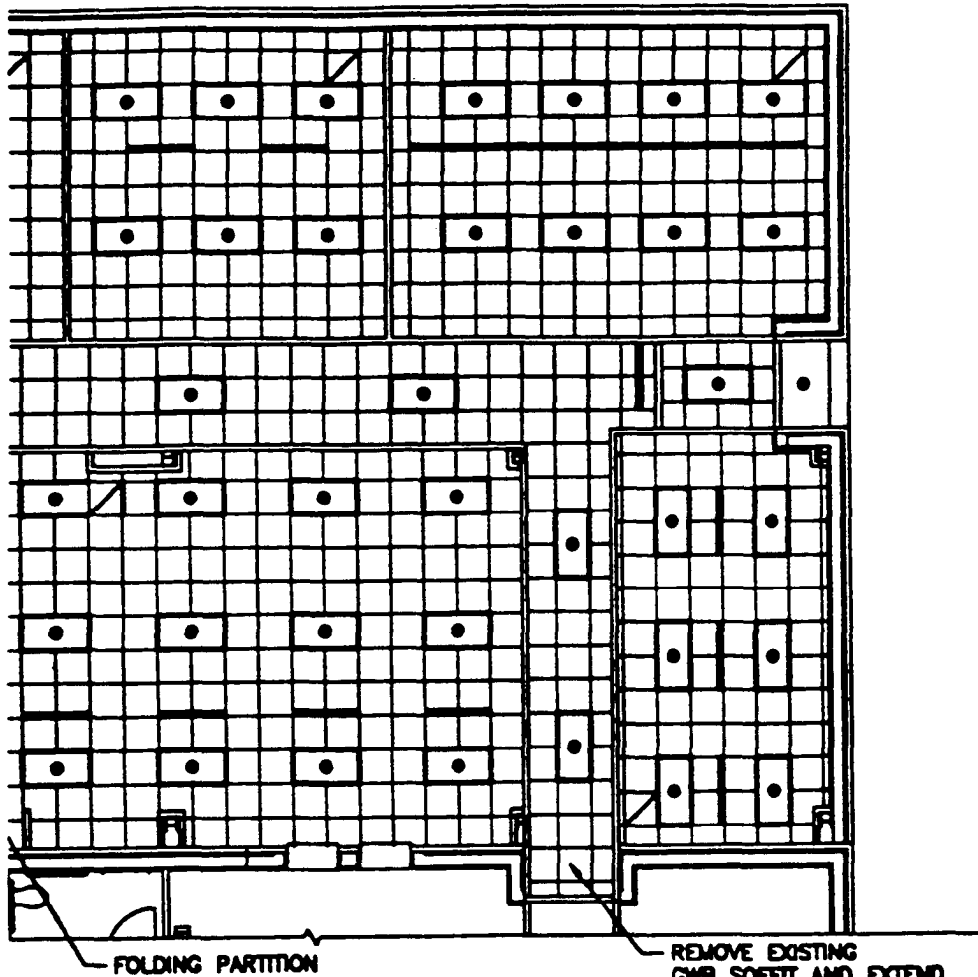

FOLDING PARTITION

REMOVE EXISTING
GWB SOFFIT AND EXTEND
NEW ACOUSTICAL CEILING
INTO EXISTING RECESS

LEGEND



600 X 600 ACOUST.
CEILING &
GRID



600 X 1200 FLUORESCENT
LIGHT FIXTURE



LINEAR DIFFUSER



RECESSED SOFFIT
LIGHT FIXTURE



RETURN/EXHAUST
AIR GRILLE



Architectural / Renovation Plan

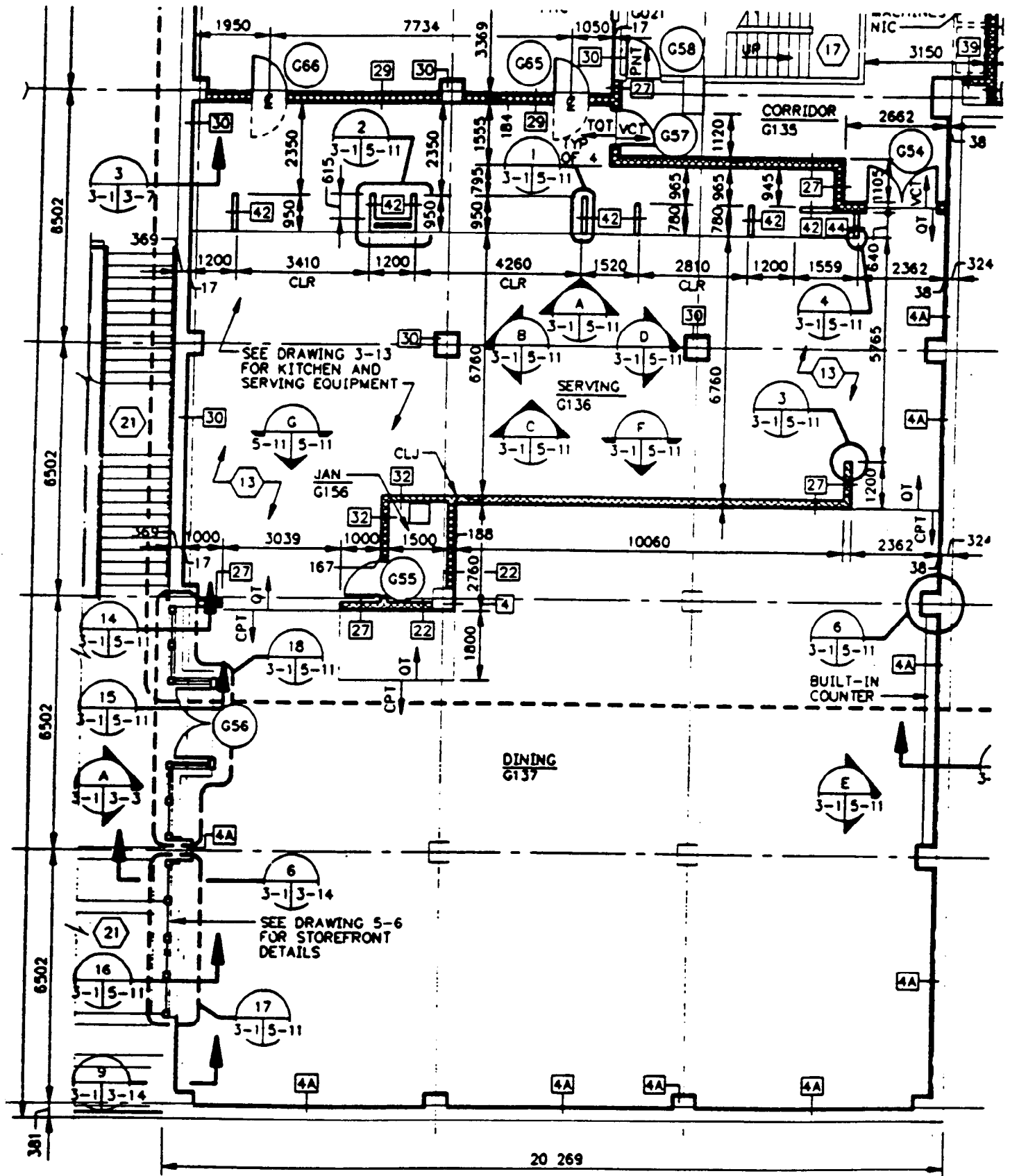

Architectural / Restroom Elevation

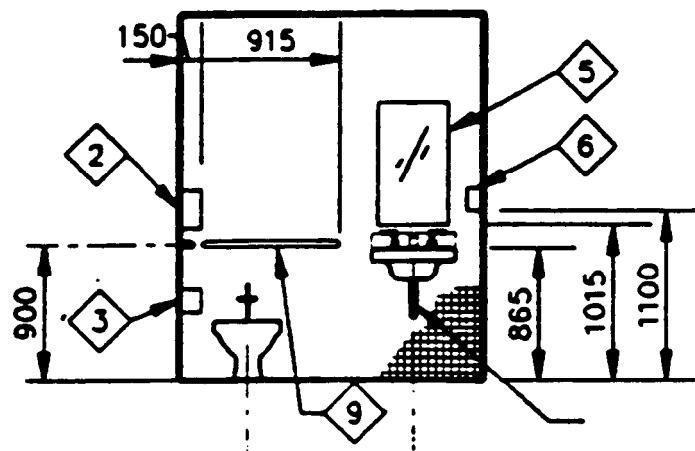
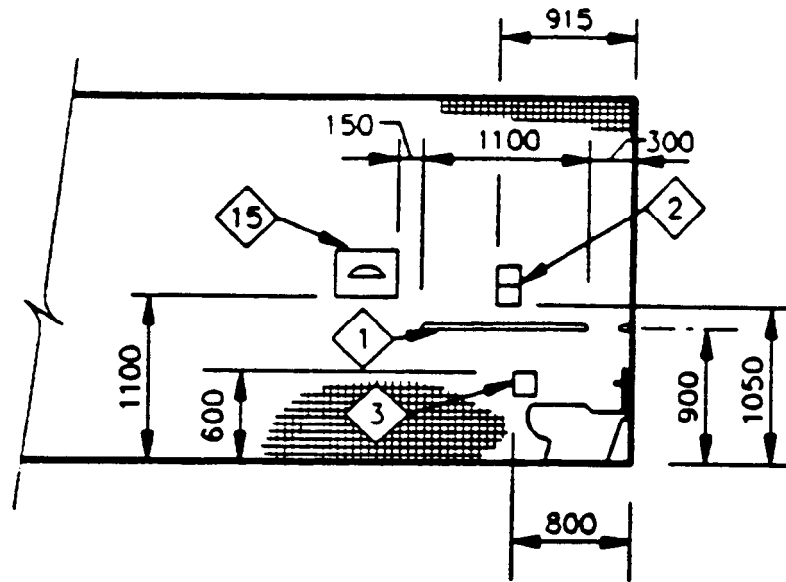
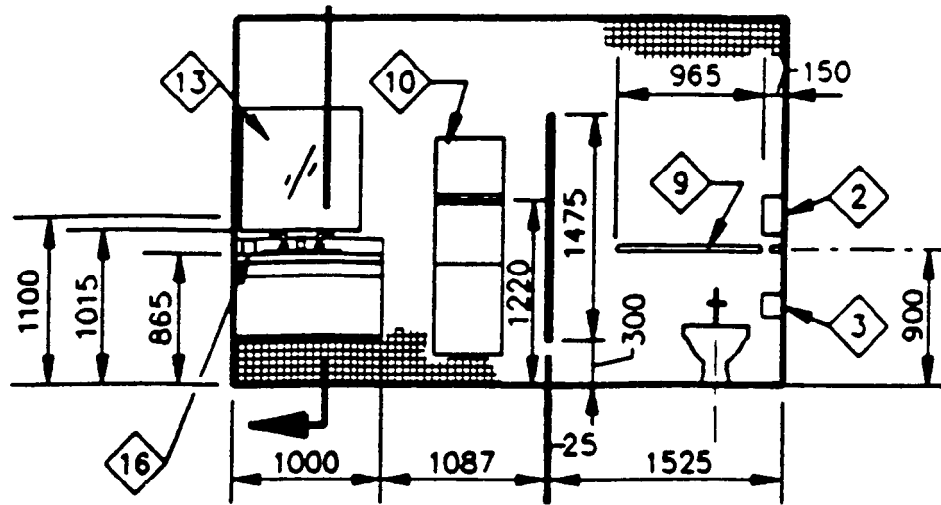

Architectural / Restroom Plan

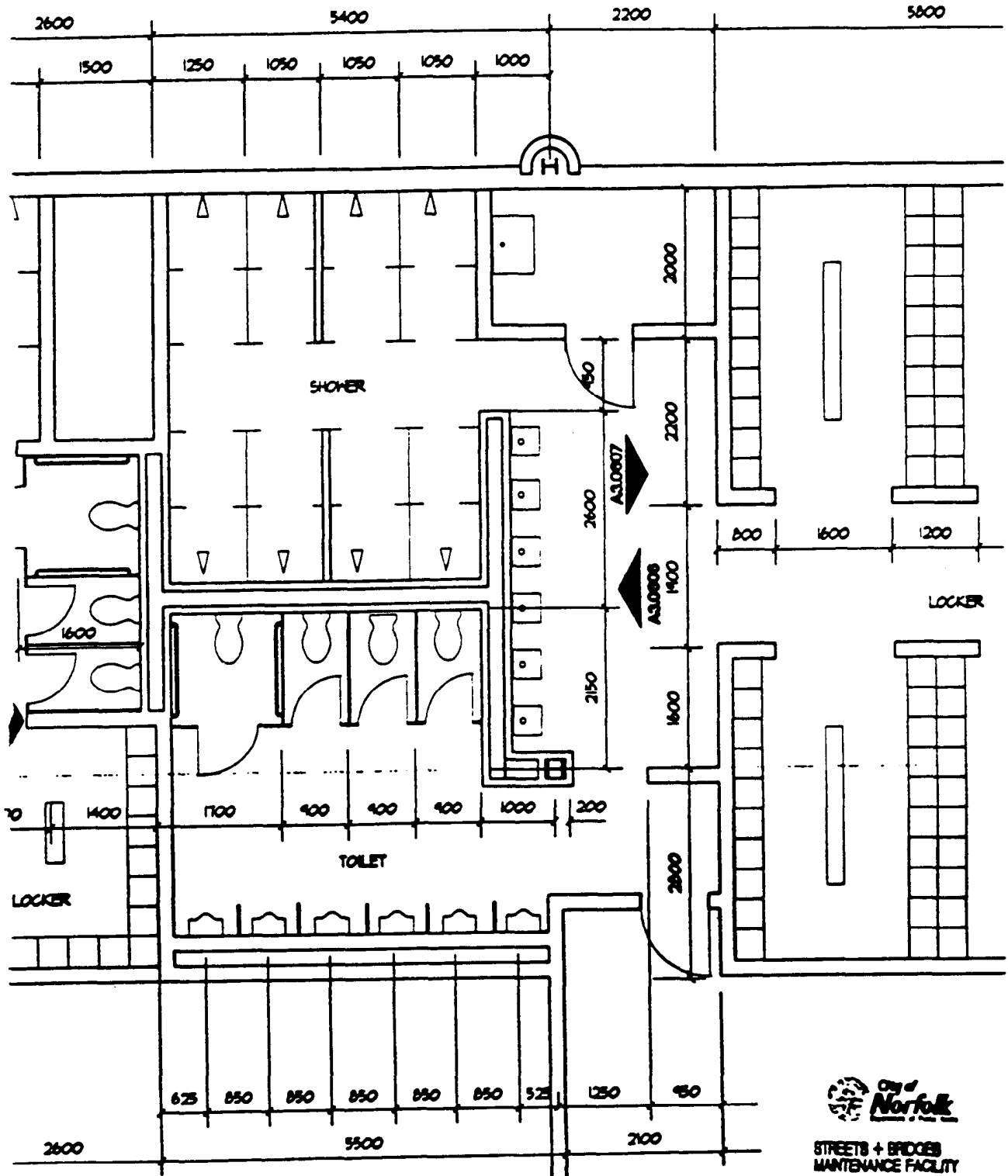

STREETS + BRIDGES
 MAINTENANCE FACILITY
 Department of Public Works
 City of Norfolk

Architectural / Restroom Plan

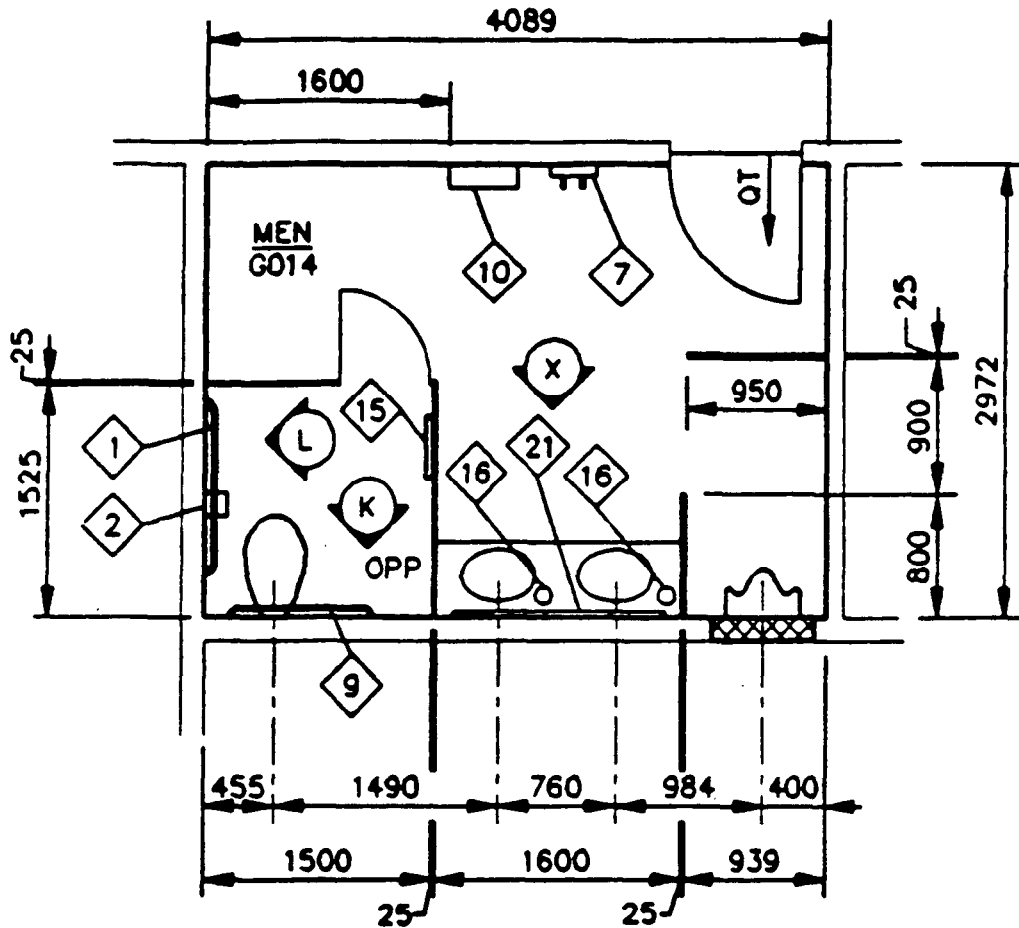

The existing space is 4089 x 2972, which can not be be easily altered.

The more important dimensions however are the installation dimensions, or design dimensions, which will be used by the installation tradespeople.

The design team has maximized use of zero and double zero dimensions:

950, 400, 800, 1500, etc, which will facilitate easier fabrication and construction.

Architectural / Security Desk

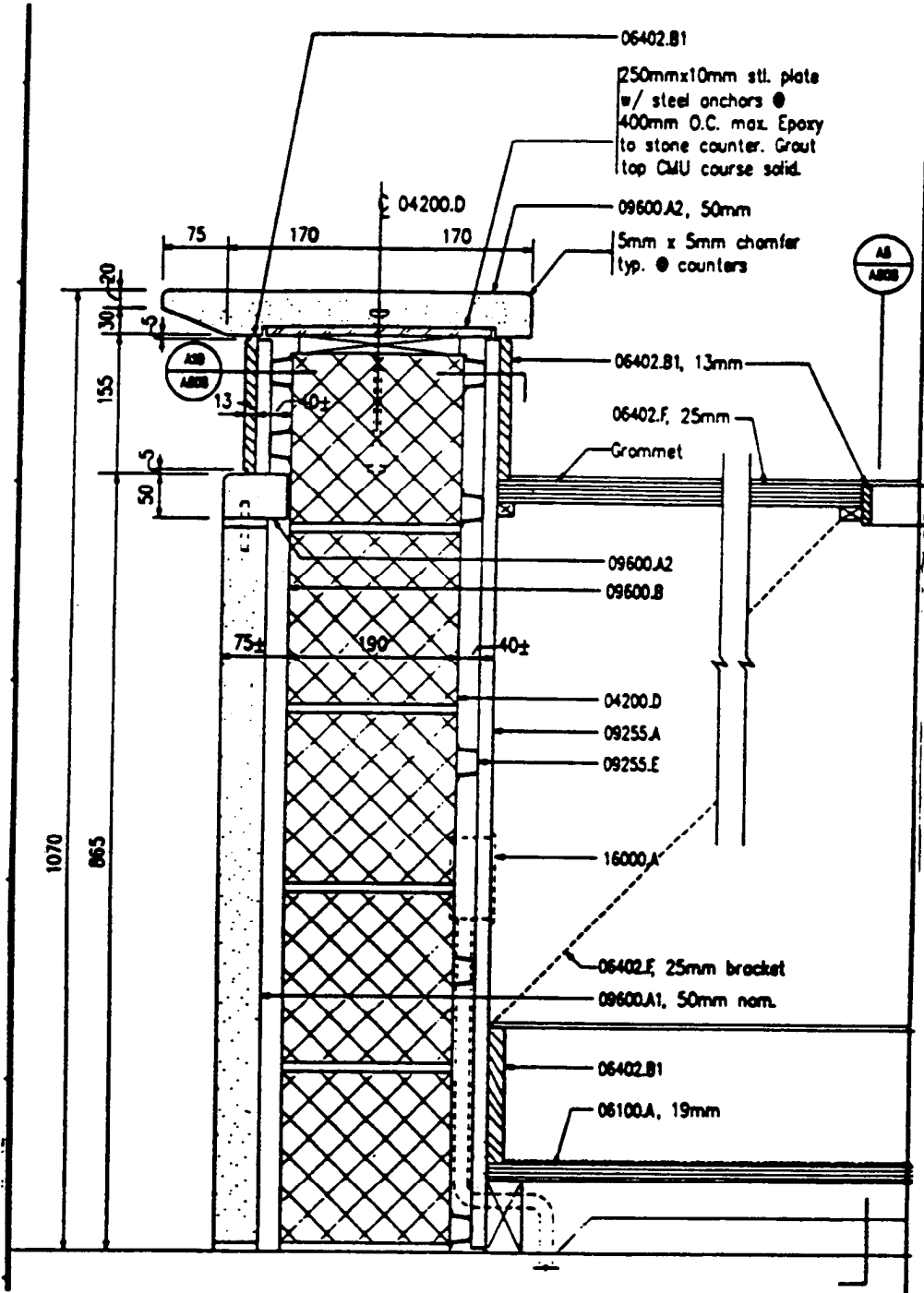

Architectural / Stair Detail

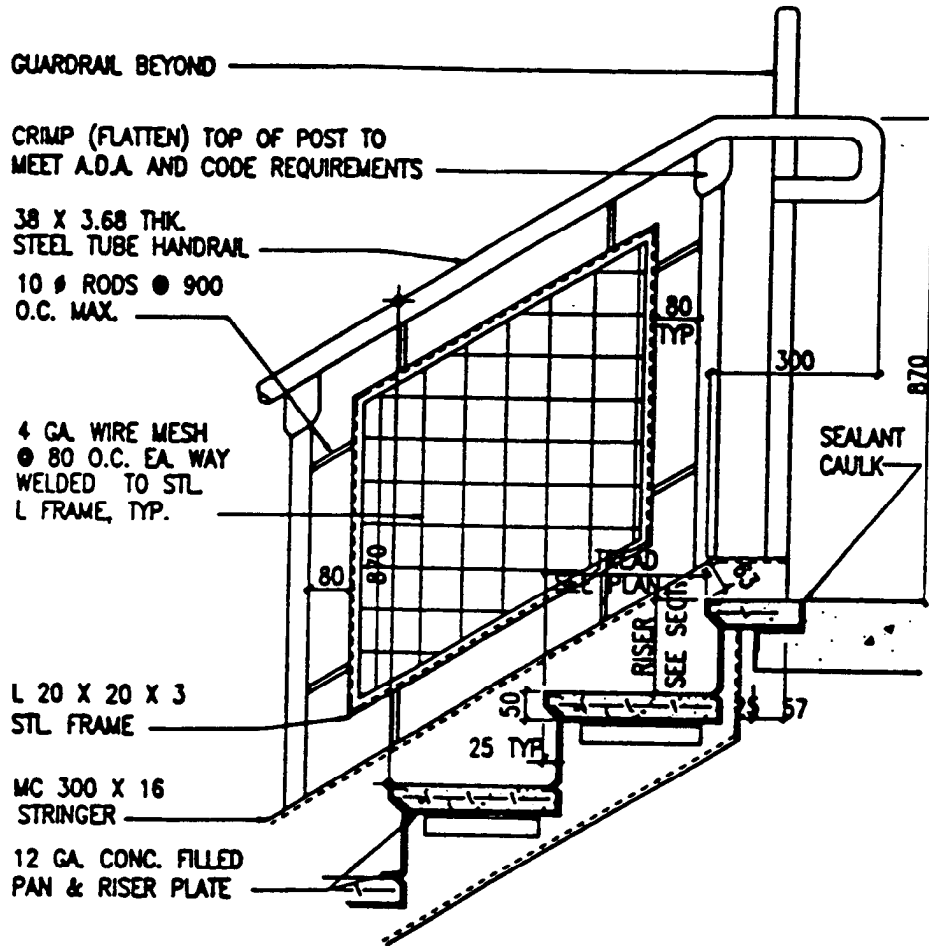

STAIR DETAIL

SCALE: 1:10

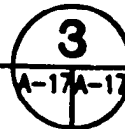

	US ARMY ENGINEER DISTRICT, BALTIMORE CORPS OF ENGINEERS BALTIMORE, MARYLAND
	DEFENSE - CEETA FORT BELVOIR, VIRGINIA PARKING STRUCTURE

Architectural / Stair Section

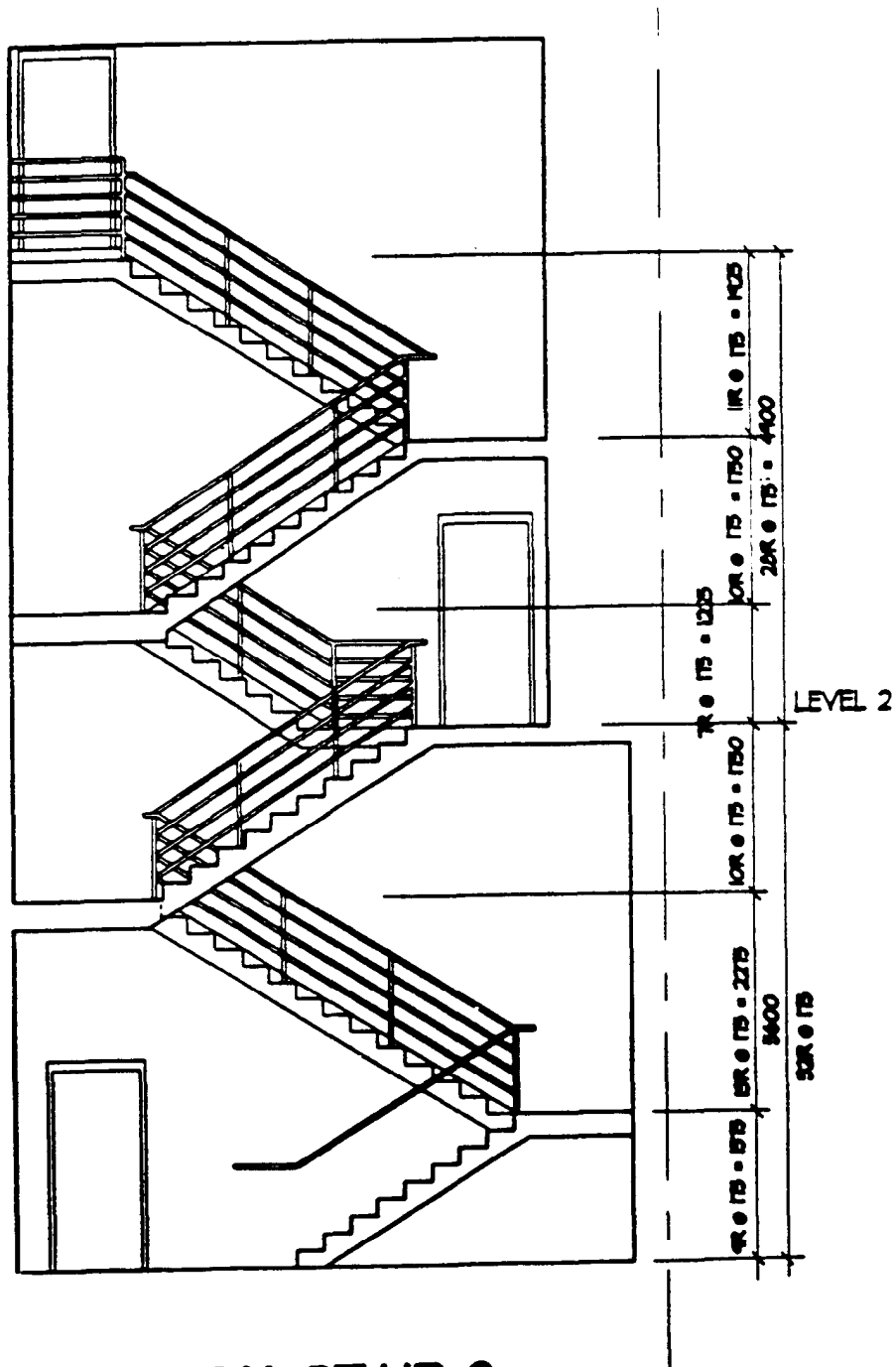

07 SECTION: STAIR 2



STREETS + BRIDGES
MAINTENANCE FACILITY
Department of Public Works
City of Norfolk

Architectural / Stair Section

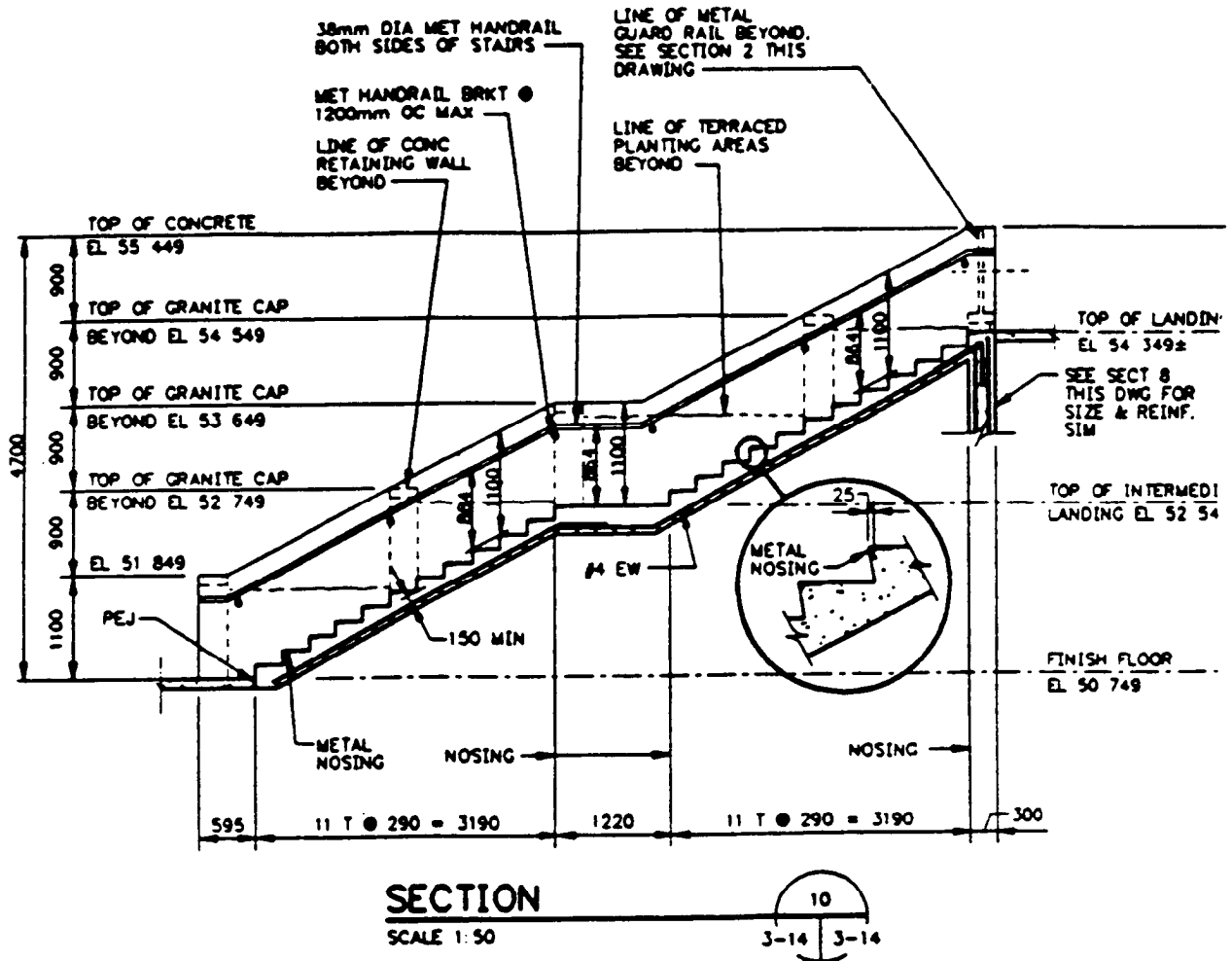

Shows how a new stair can be added to an existing building using clean, rounded metric dimensions.

Architectural / Storefront Detail

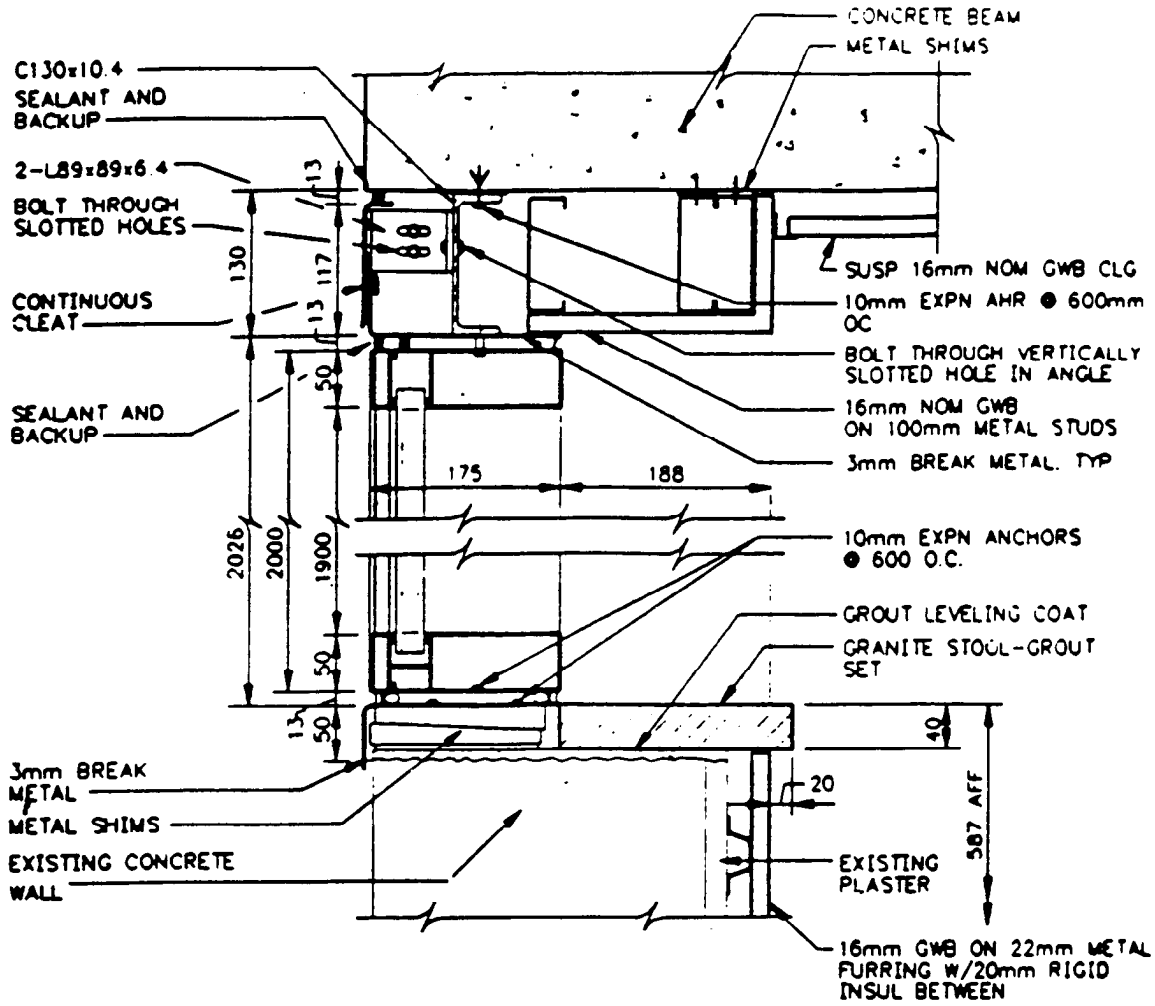

Architectural / Wall Section

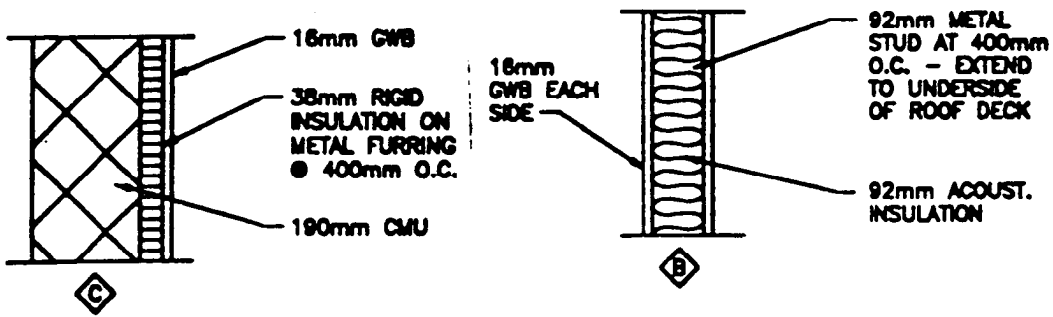

Architectural / Wall Section

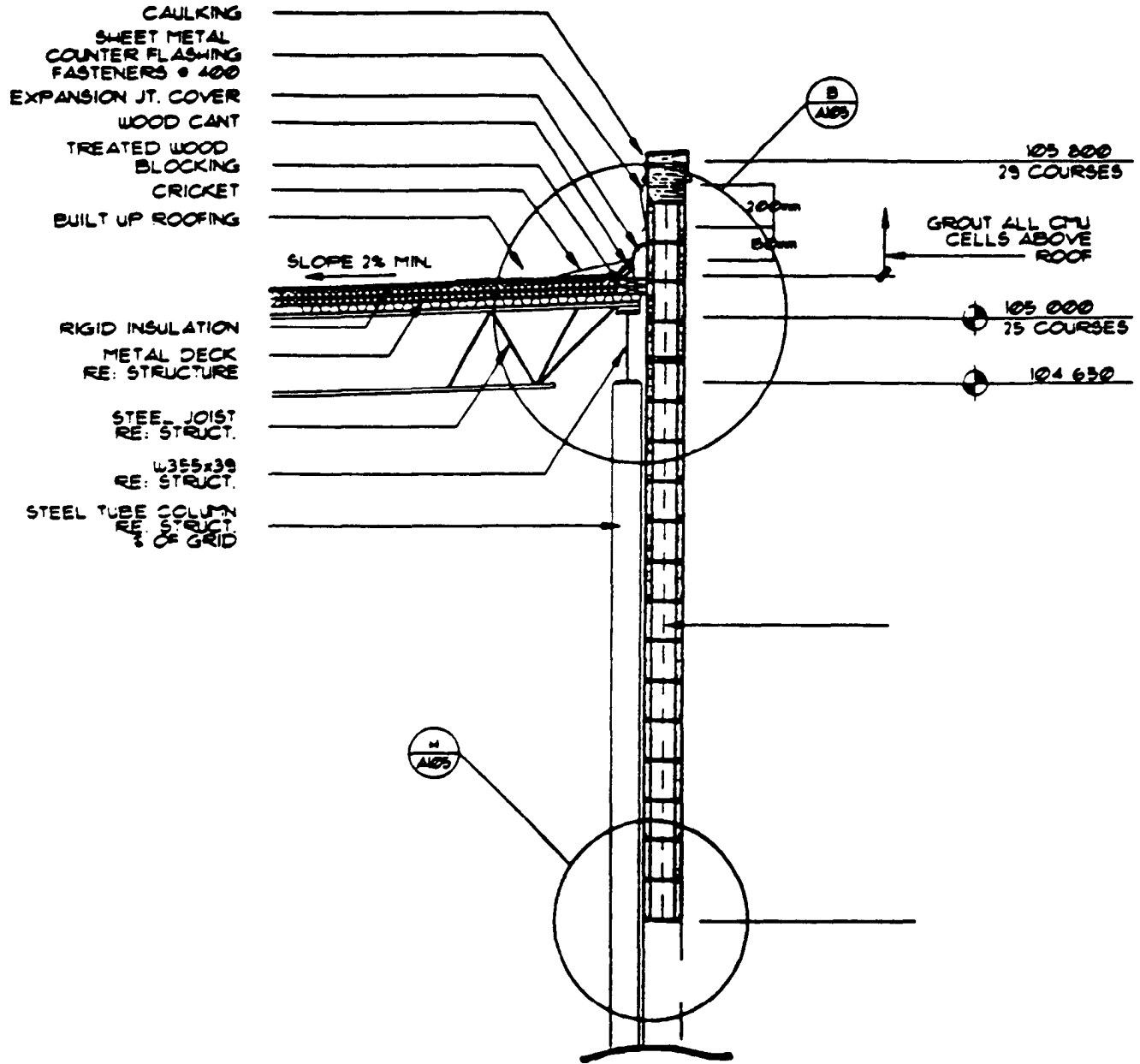

Note: Wall Section Continues on Next Page

Source: GSA Denver Office

Shows exterior block wall section. Project already constructed.

Architectural / Wall Section

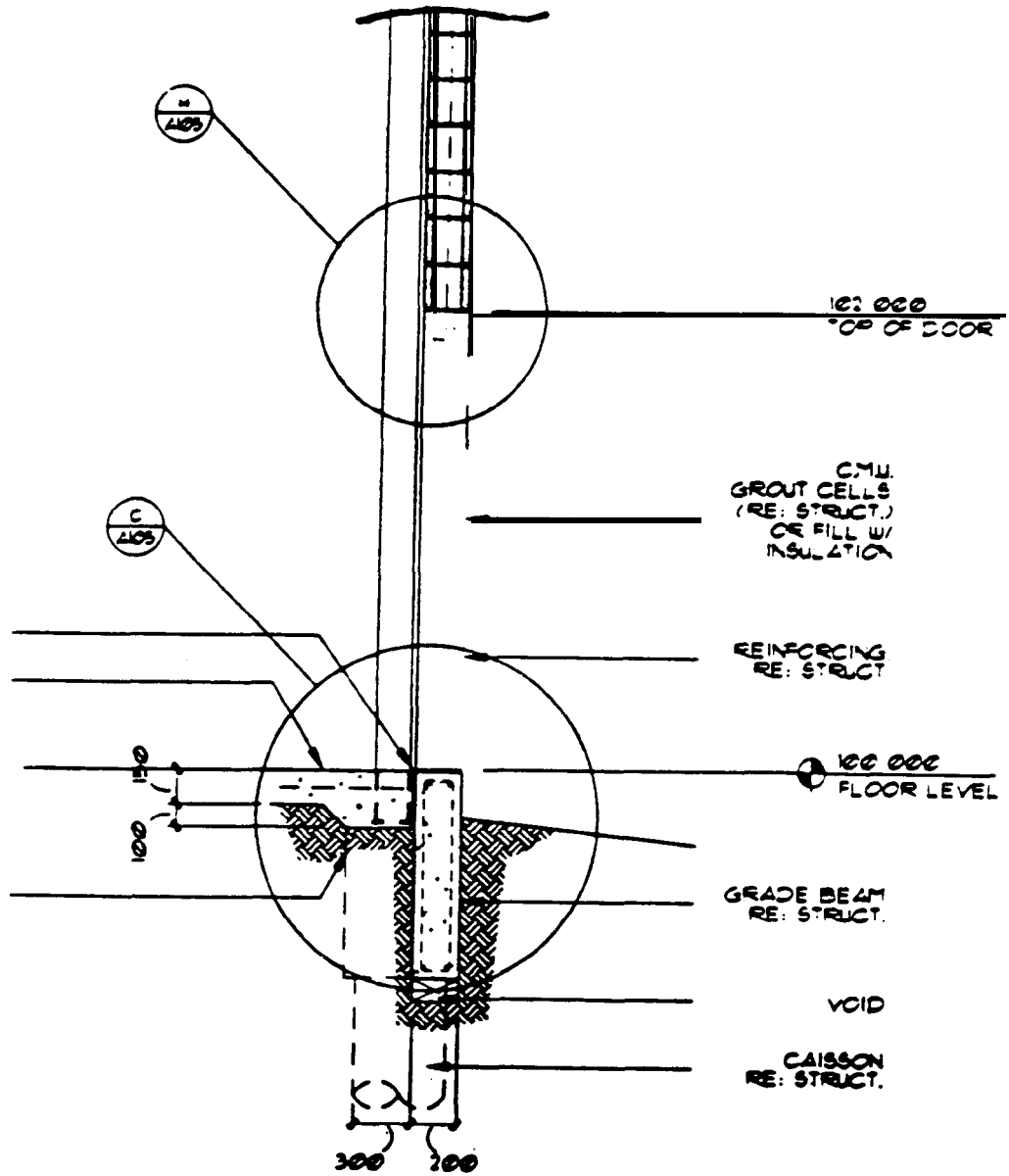

2
A103

WALL SECTION

SCALE: 1/20

Architectural / Window

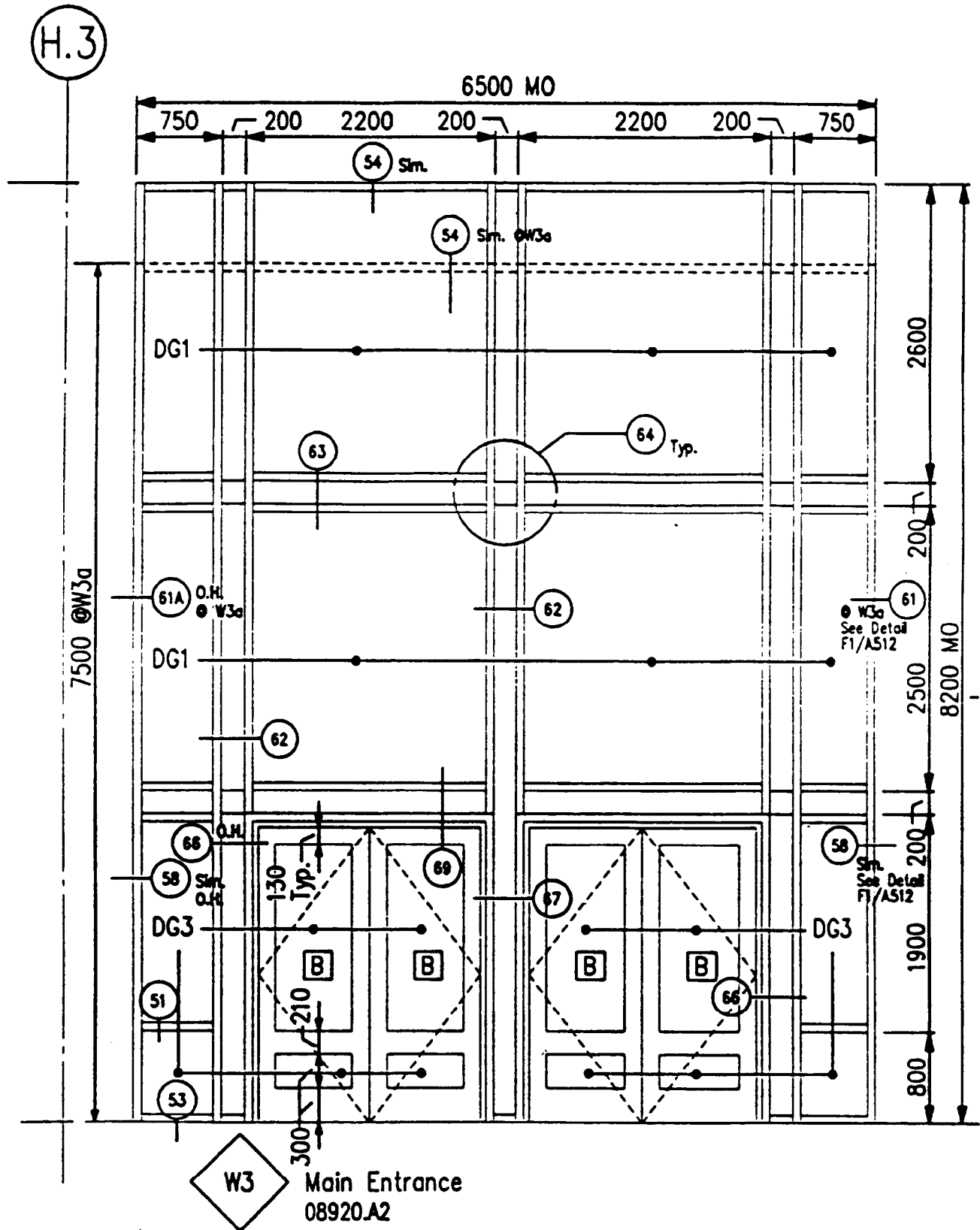

Civil / Harbor plan

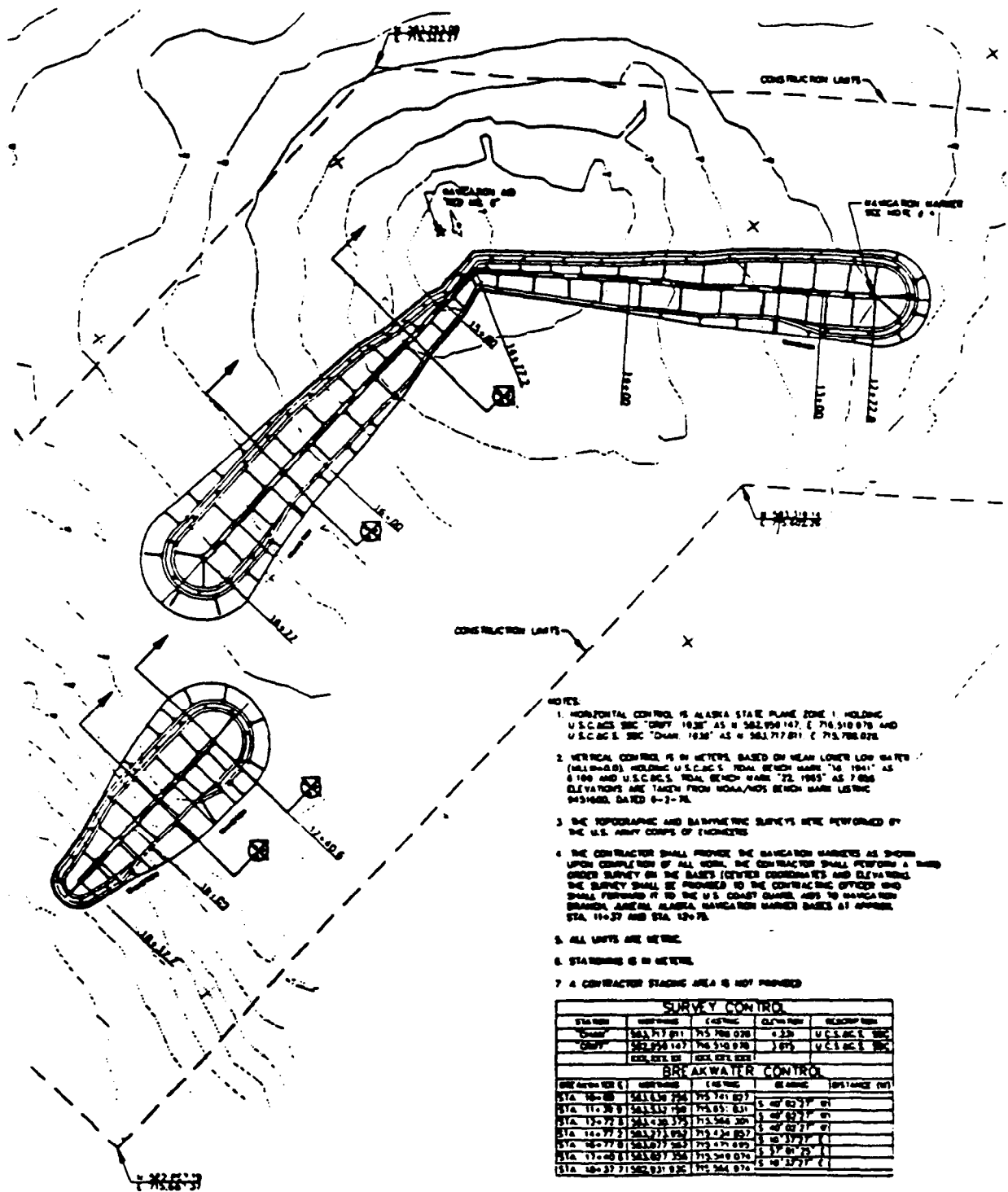

- NOTES**
1. HORIZONTAL CONTROL IS ALASKA STATE PLANE ZONE 1 HOLDING U.S.C.M.C. SEC "CRPT 1928" AS W 562,958.147, E 716,510.076 AND U.S.C.M.C. SEC "CHAM 1928" AS W 562,777.071, E 715,706.076
 2. VERTICAL CONTROL IS IN METERS, BASED ON MEAN LOWER LOW SEA (MLLWS) HOLDING U.S.C.M.C.'S TIDAL BENCH MARK "M 1961" AS 6.100 AND U.S.C.M.C.'S TIDAL BENCH MARK "T2 1965" AS 7.026. ELEVATIONS ARE TAKEN FROM NOAA/TDS BENCH MARK LISTING 0454660, DATED 6-7-76.
 3. THE TOPOGRAPHIC AND BATHYMETRIC SURVEYS WERE PERFORMED BY THE U.S. ARMY CORPS OF ENGINEERS.
 4. THE CONTRACTOR SHALL PROVIDE THE BANGRAON MARKERS AS SHOWN UPON COMPLETION OF ALL WORK. THE CONTRACTOR SHALL PERFORM A THIRD ORDER SURVEY ON THE BASIS (CENTER COORDINATES AND ELEVATIONS). THE SURVEY SHALL BE PROVIDED TO THE CONTRACTING OFFICER WHO SHALL PERFORM IT TO THE U.S. COAST GUARD AND TO BANGRAON BRANCH, JUNEAU, ALASKA. BANGRAON MARKER DATA AT OFFICE STA. 110-37 AND STA. 130-75.
 5. ALL UNITS ARE METRIC.
 6. STAIRWAYS IS IN METERS.
 7. A CONTRACTOR STAGING AREA IS NOT PROVIDED.

SURVEY CONTROL				
STATION	HORIZONTAL	ELEVATION	DATE	DESCRIPTION
"CHAM"	562,777.071	715,706.076	4-23	U.S.C.M.C. SEC.
"CRPT"	562,958.147	716,510.076	1-27	U.S.C.M.C. SEC.
	562,958.147	716,510.076		

BREAKWATER CONTROL				
LINE NUMBER	NORTHING	EASTING	BEARING	DISTANCE (M)
STA. 10-28	561,120.754	715,701.027		
STA. 11-30-B	561,115.750	715,651.831	S 49° 02' 37" 07	
STA. 12-72-B	561,026.375	715,504.204	S 49° 02' 37" 07	
STA. 14-77-B	561,271.075	715,024.027	S 49° 17' 17" 07	
STA. 08-77-B	561,077.563	715,071.027	S 37° 01' 25" 07	
STA. 11-40-B	561,027.358	715,206.076	S 40° 27' 37" 07	
STA. 10-37	562,931.026	715,504.076		

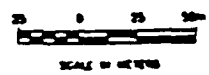

SITKA HARBOR
SITKA, ALASKA

SITKA HARBOR
PLAN VIEW

Mechanical/Distribution

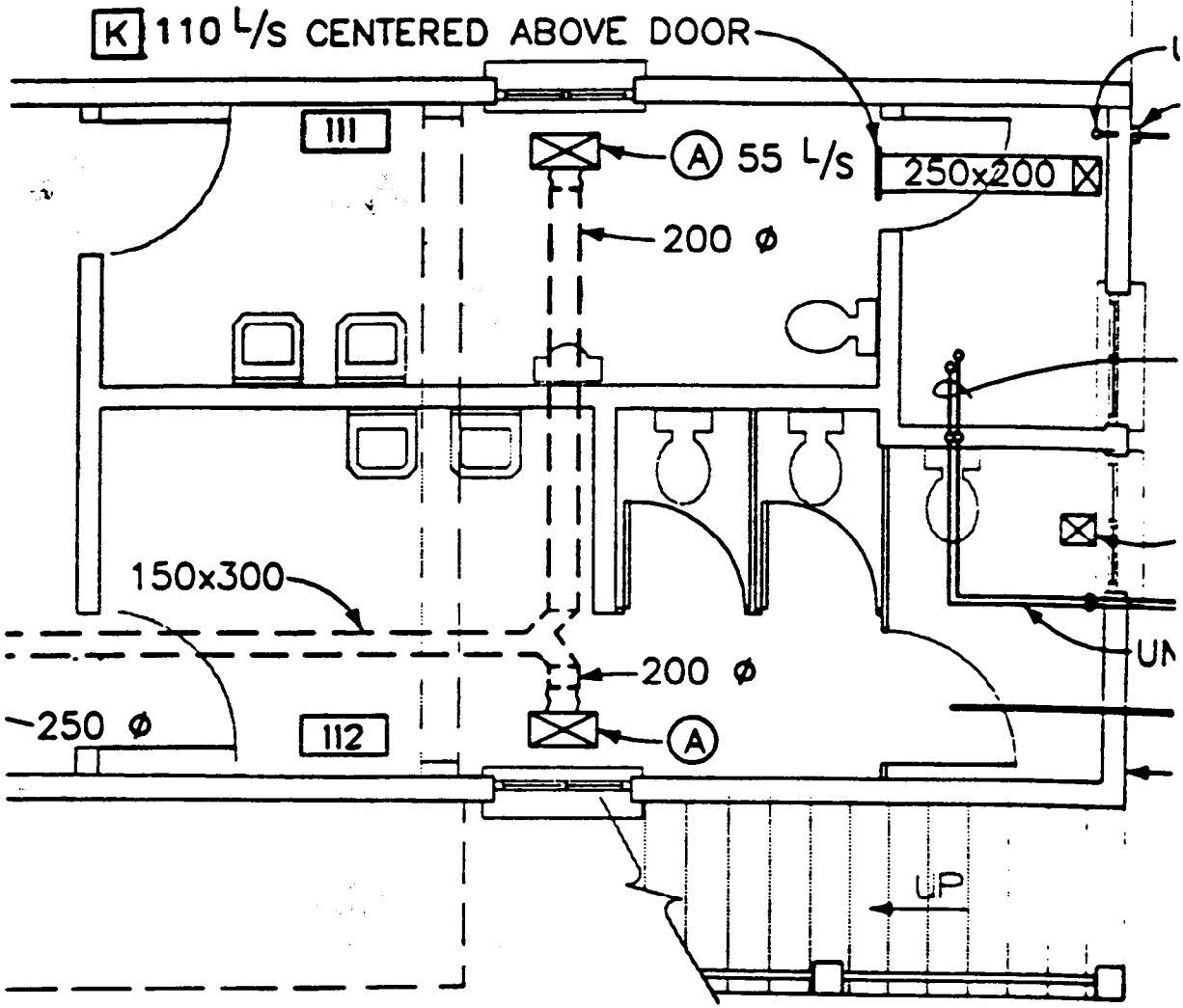

Demonstrates round ductwork sized in recommended hard metric increments, rectangular ductwork sized in recommended 50 and 100 mm increments, and airflow rates in rounded, even increments of 10 or 5 L/s.

Source: National Park Service

Mechanical / Air Distribution

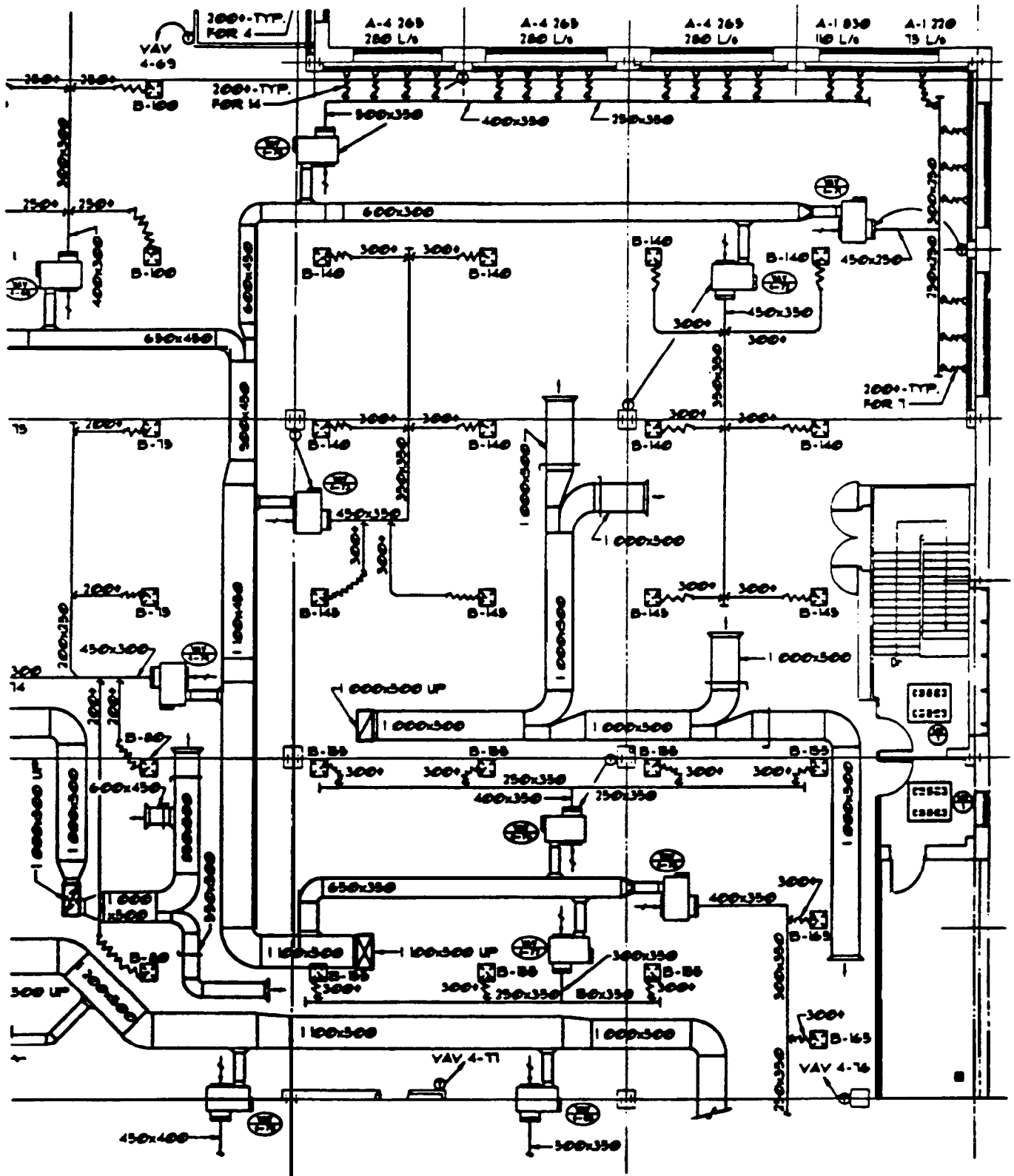

Source: Department of Veterans Affairs project

Scientific / Site Plan

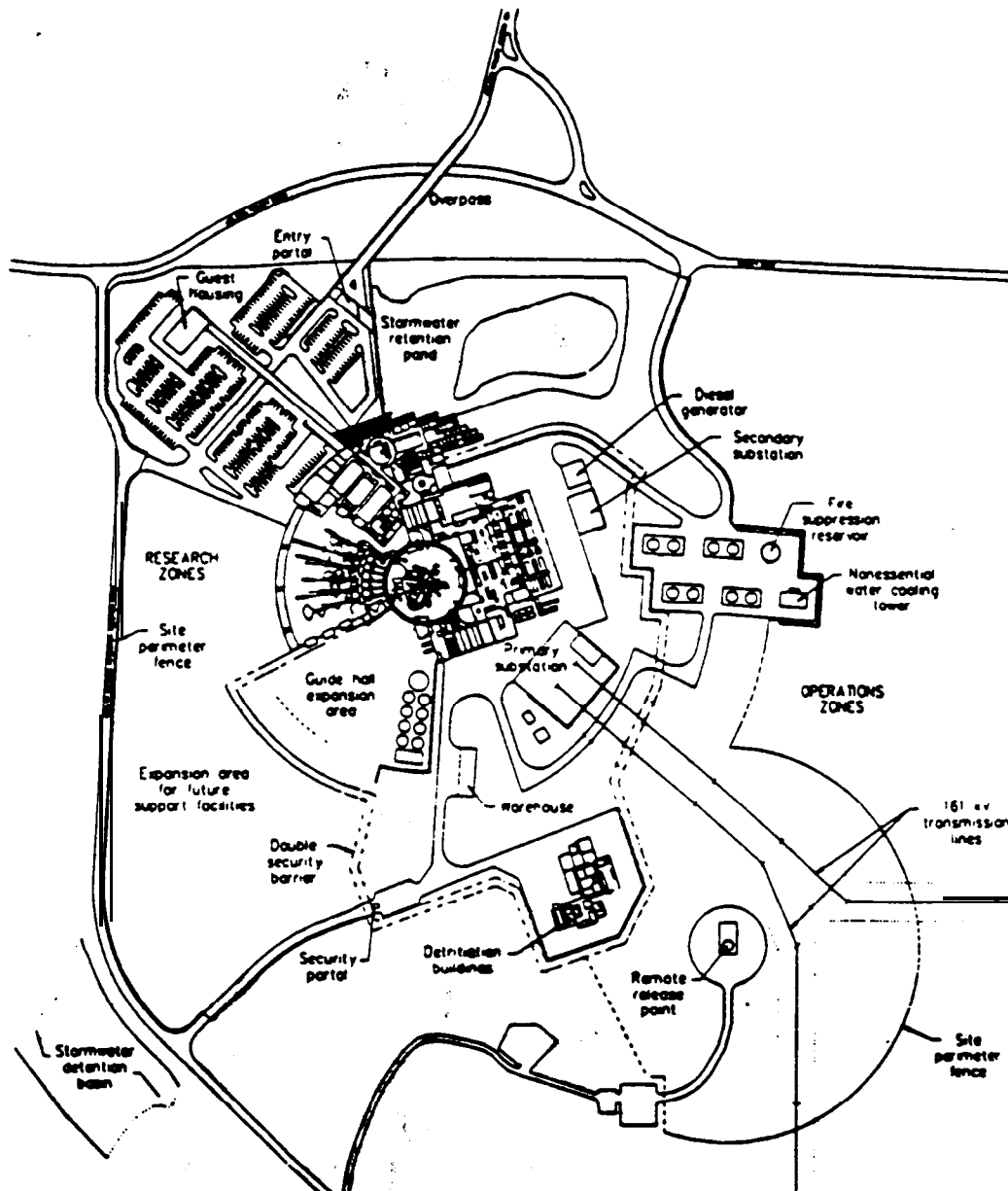

Shows conceptual sketch of the Advanced Neutron Source (ANS) site plan, a new multi-billion dollar world class laboratory for advanced research.

Project is now in development in metric by the US Department of Energy.

The baseline design involves a 16 hectare site in Tennessee. From grade to top of main structure is about 180 m. Project involves two independent 161 kV transmission line sources: TVA Ft Loudoun Dam, and one fed from the TVA Bull Run Steam Plant.

Scientific / Sketches

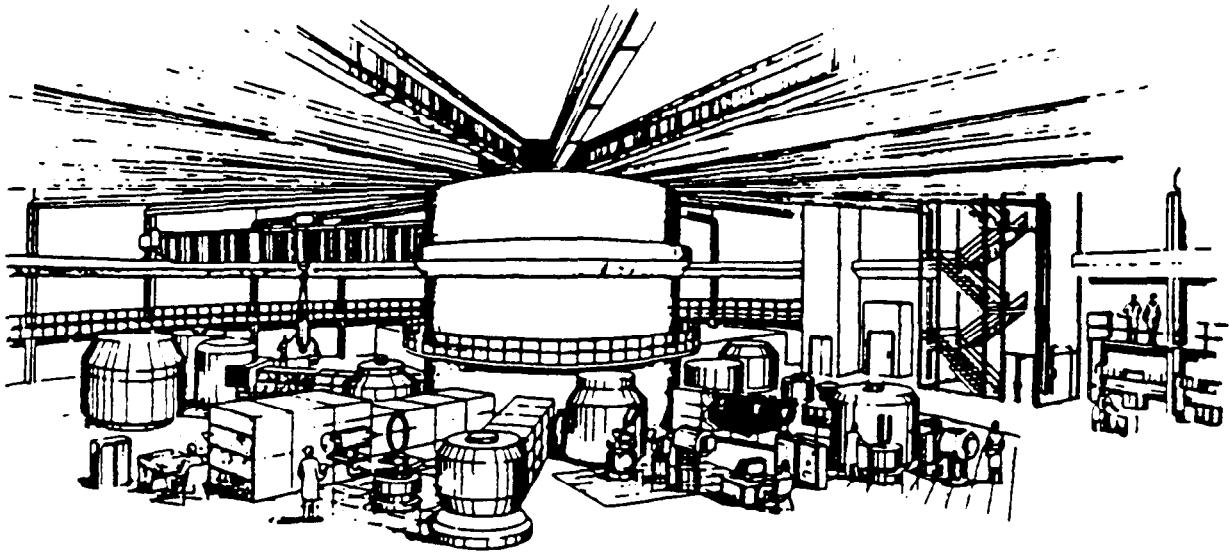

Conceptual Sketch: Ground Floor Beam Room

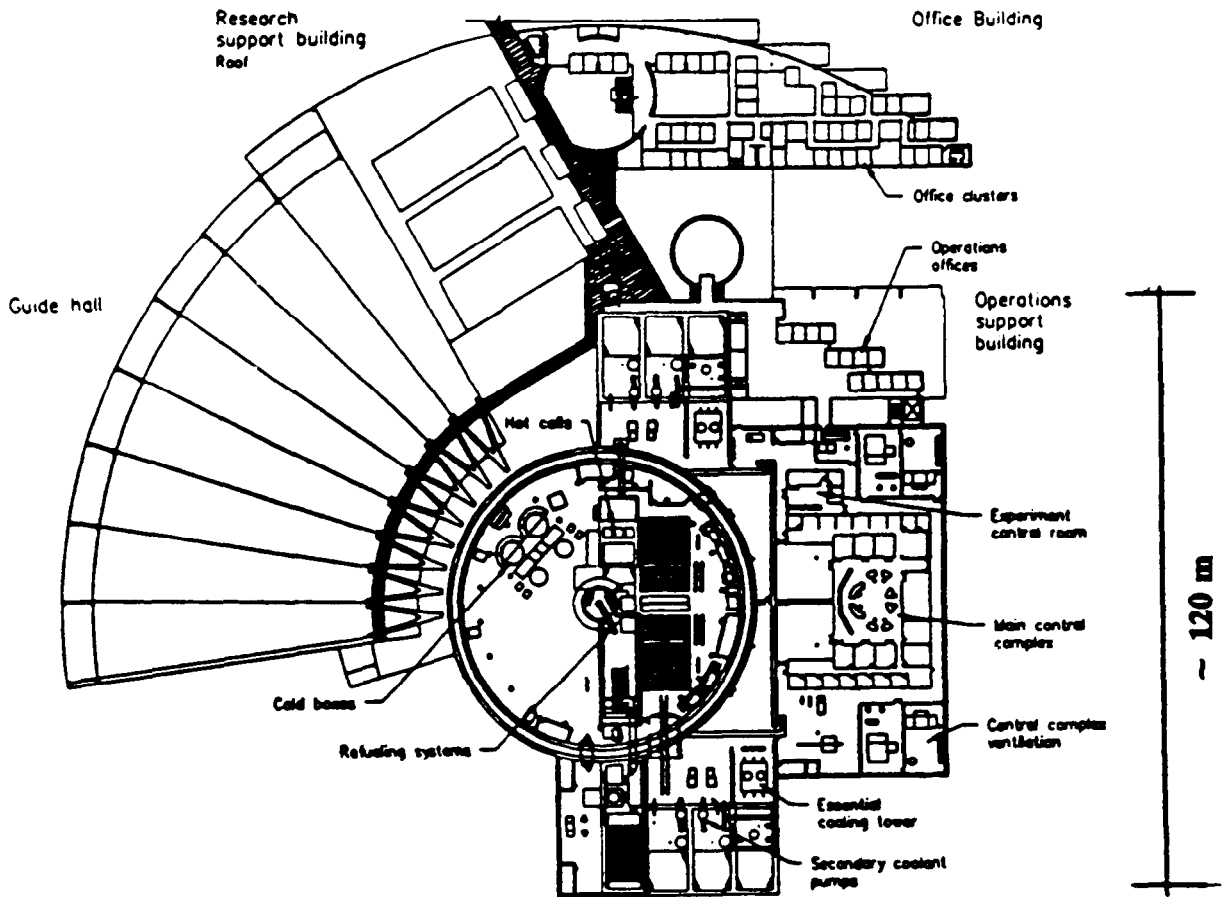

Intermediate Floors of the main ANS Building Complex

Structural I Base Plate

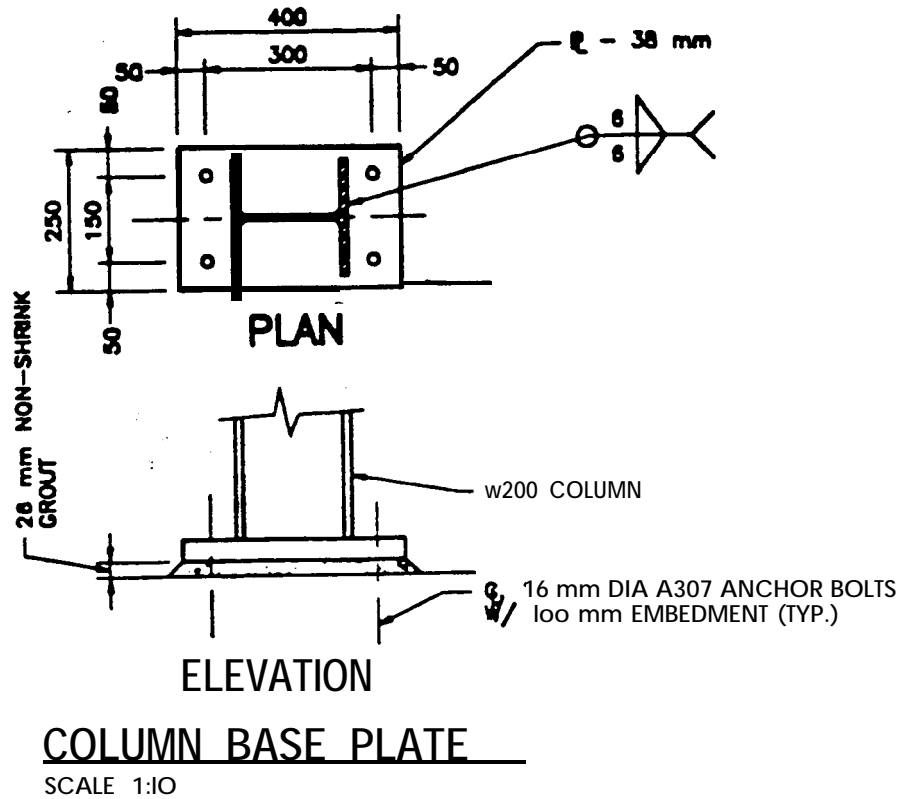

Shows professionally rounded base plate dimensions.

Recommendation: While M16 is a preferred anchor bolt diameter, see Fastener Data for anchor bolt standard references.



Structural / Foundation Wall

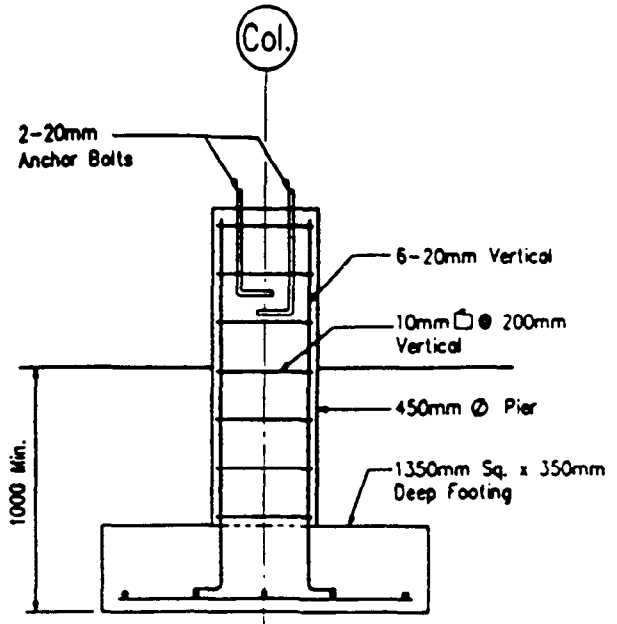
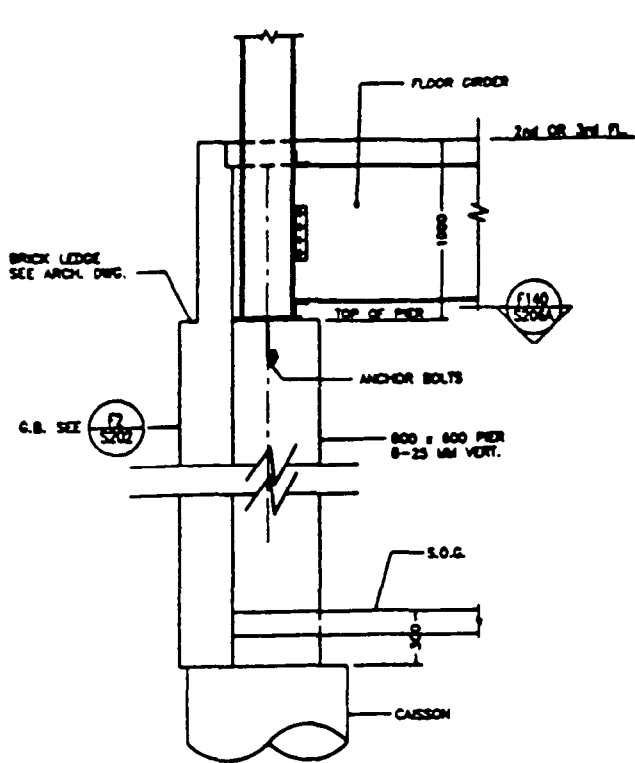

Note:
Refer To E5/C120
For Plan Detail.

TYPICAL PIER IN
FOUNDATION WALL

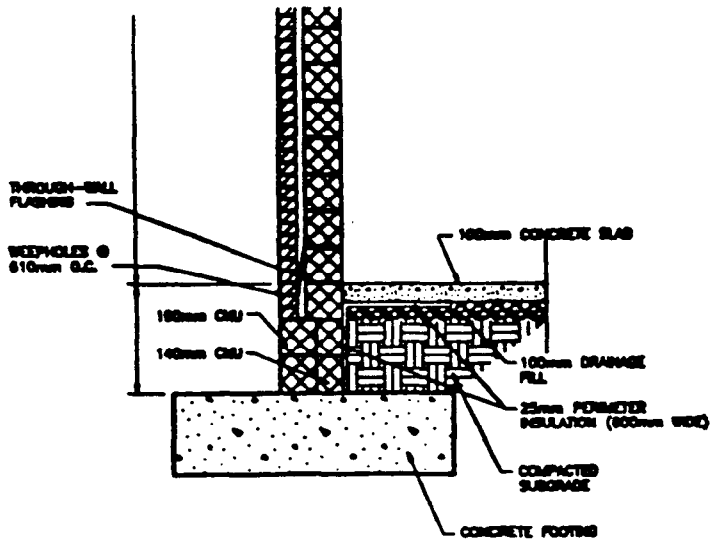

WALL SECTION **B**
SCALE: 1:20 **A/A**



Structural / Foundation Wall

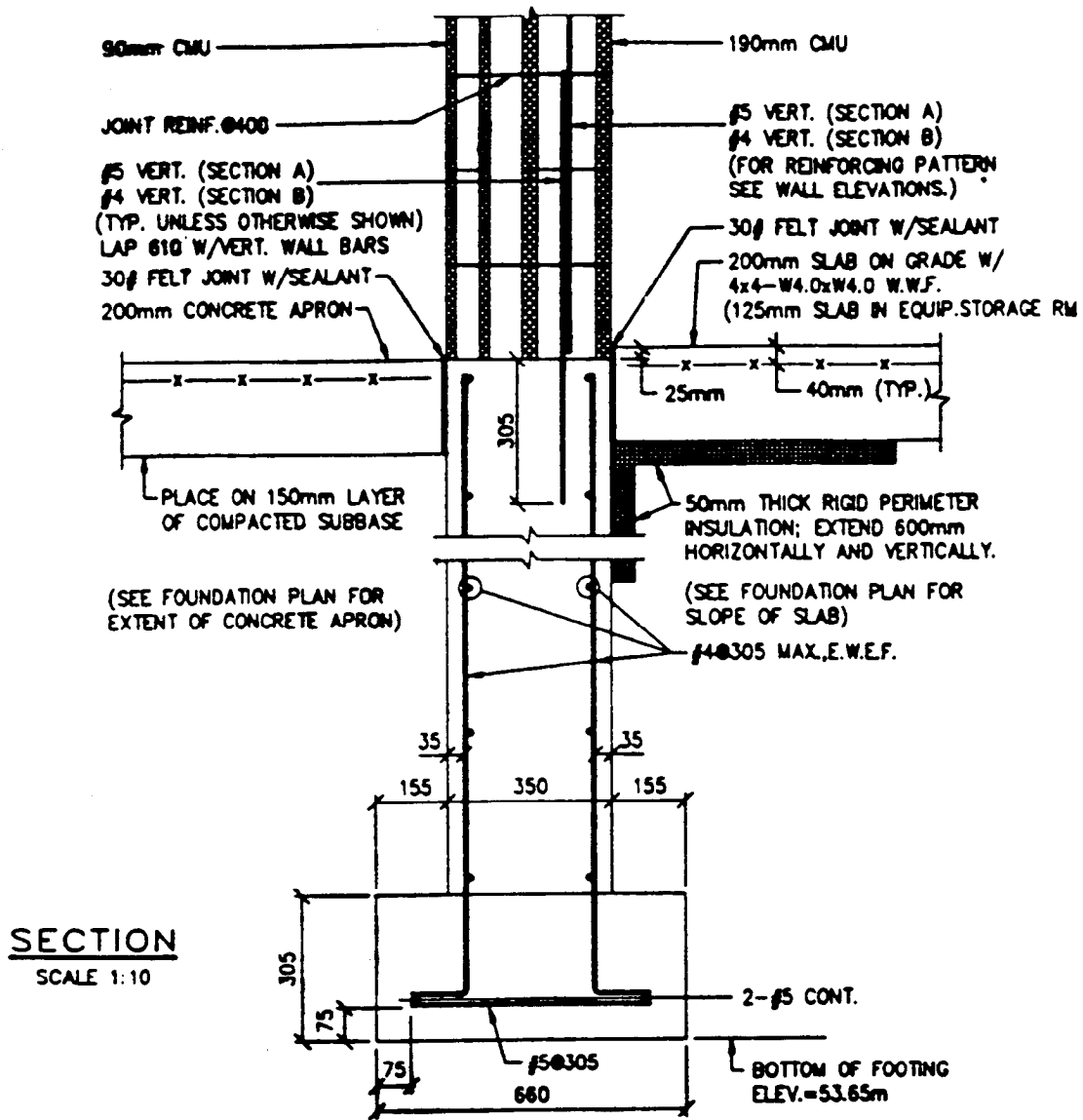

Shows sample foundation of a new facility currently in construction in northern New York state. Project is being managed by the GSA New York City office.

Note: We would now specify hard metric rebar (ex, 15M bars)

- Recommendation 1: Consider 300 mm for vertical reinforcement embedment depth.
- Recommendation 2: Consider 300 mm for bar spacing in footing and foundation wall, as well as for footing depth.

Structural / Grade Beam

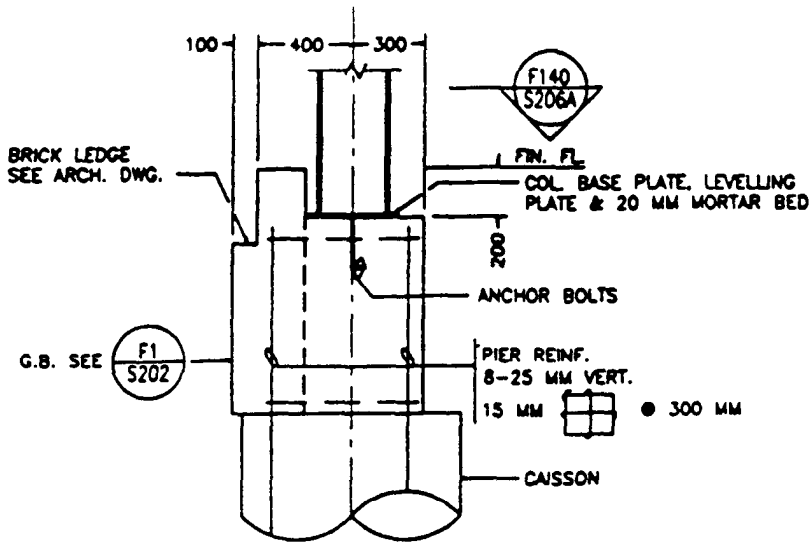

TYPICAL PIER
IN GRADE BEAM

Both details from GSA
Philadelphia project.

Structural / Reinforcement

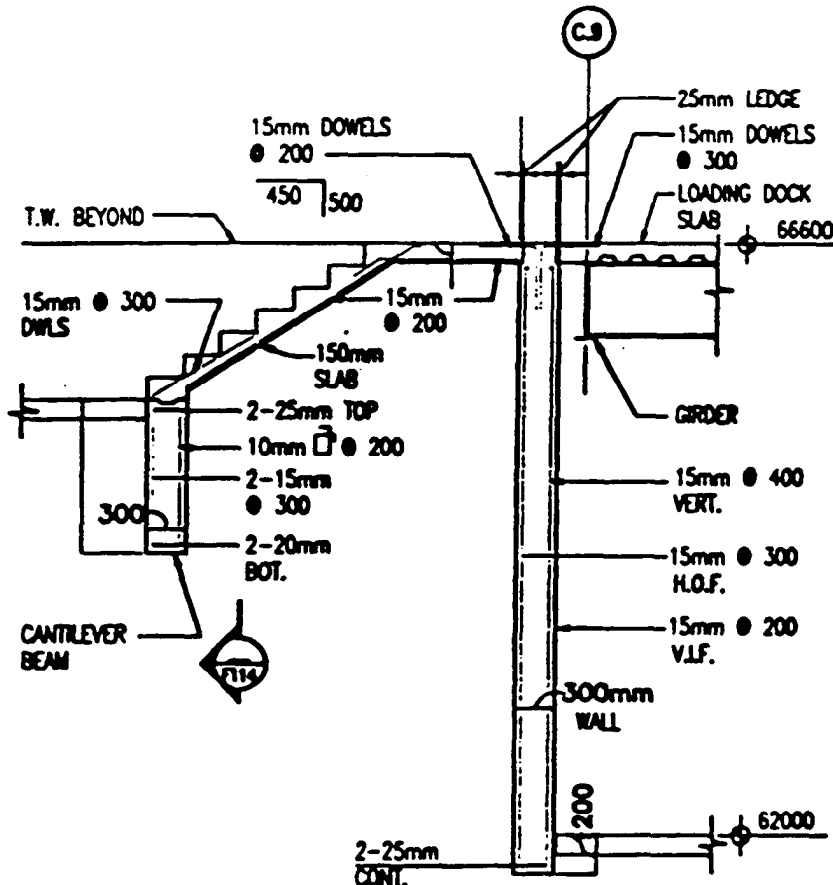

F113
SCALE: 1:20

All projects should now
use hard metric rebar as
shown here, only use the
M suffix. (ex, 15M, 20M)

Structural / welds

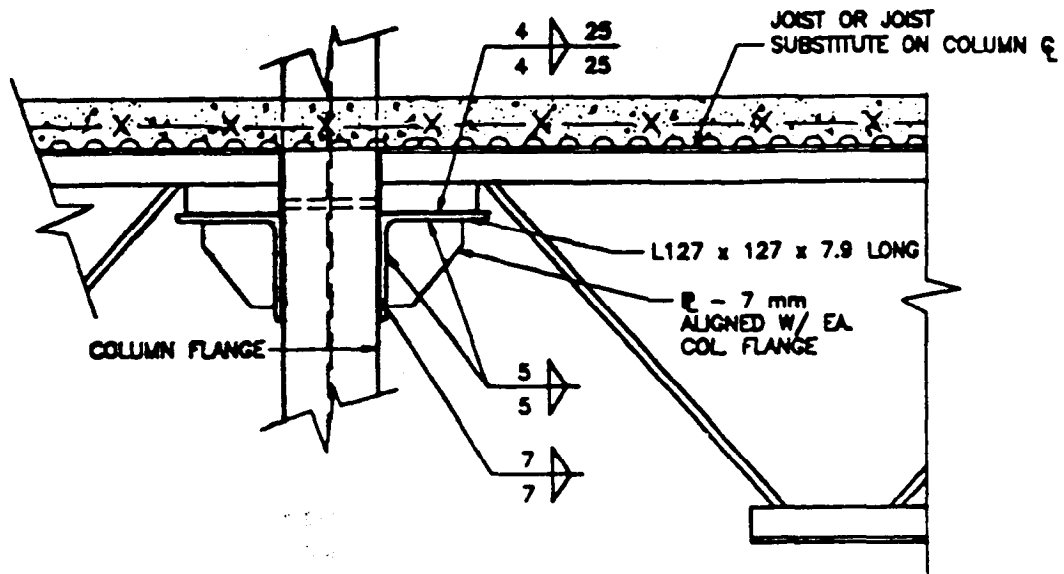

JOIST CONNECTION ● COLUMN C
SCALE: N.T.S.



Road Design Data / Colorado

DESIGN/PLAN PREPARATION

- All Right-of-Way and Construction Plans shall be drawn to metric scales:
Plan sheets: 1:1000 (rural) [Use 1 m = 1000 m, not 1 cm = 10 m]
1:500 (urban)
Owlership maps: 1:5000
- All Engineering Design shall be converted to metric units including the definition of the degree of curve from the 100 foot arc definition to the radius definition.

The legal descriptions shall be written as follows:

- Angular measurement shall continue to be made in degrees, minutes, and seconds.
- Surveyed distances shall be given in meters.
- Deed distances shall given in parenthesis in the units they were recorded.
- Areas shall be given in both conventions. In urban locations, square meters shall be used with the square footage given in parenthesis. In rural locations, hectares shall be used with acres given in parenthesis.
- All Right-of-Way plan tabulation of properties sheets shall give both English and metric units of area in tabular form.
- Right-of-Way professionals shall reserve the right to redraft any drawings in English units for the purpose of public presentations and/or court proceedings.

STATIONING AND CROSS-SECTIONS

A station concept based on 1 km (1+000.00) will be used for metric plans. For example, Station 12+273.96 indicates a point 273.96 m forward of kilometer station 12+000.

Use an equivalent conversion from English to metric when re-establishing points from a previously run survey. For example, P.I. Station 456+35 from a 1965 survey using English units would be defined as Kilometer Station 13+909.548 (45,635 ft. + 3280.84 ft./km = 13.909 548 km) in a metric survey. The kilometer stationing on new alignments is arbitrary.

Standard cross-section intervals of 20 meters should be used where alignment is maintained over existing embankments and thru rolling terrain. Although 20 meters should be considered the standard, a larger interval may be considered when uniform templates are used over flat terrain. Additional cross-sections should be provided to reflect abrupt changes in either the template or the existing ground.

Road Design Rata / Colorado (continued)

PROPOSED FEATURES ON ROADWAY PLANS

The location of all proposed features should be given in meters or fractional parts of meters to the following accuracy:

- All proposed horizontal alignment data should be given to an accuracy of 0.001 meters.
- Metric curve radii should be in 5 meter increments.
- Vertical profile alignment data should be shown with V.P.I. Stations at even 10 m stations, V.C. Lengths in 20 m increments, and V.P.I. Elevations given to 0.001 m accuracy, where practical.
- All other vertical elevations (breaks in ditch grades, pipe invert elevations, etc.) should be shown to the closest 0.01 meters.
- The location of all proposed features should be shown to the closest one meter, where practical, and never closer than 0.1 meter. The following increments are recommended:

Drive locations	Closest 1.0 meters
Culvert locations	Closest 1.0 meters
Horizontal ditch grade breaks	Closest 1.0 meters
Guard rail limits	Closest 0.1 meters

This material is from the Colorado Department of Transportation,
Draft Metric Conversion Manual, September 1993.

Road Design Data / GSA

The road design drawings contained within this GSA section are details taken from a project now in construction in Arizona, managed by the GSA office in San Francisco.

Project involve construction of new facilities on the Mexican border, as well as highway construction to Arizona DOT standards.

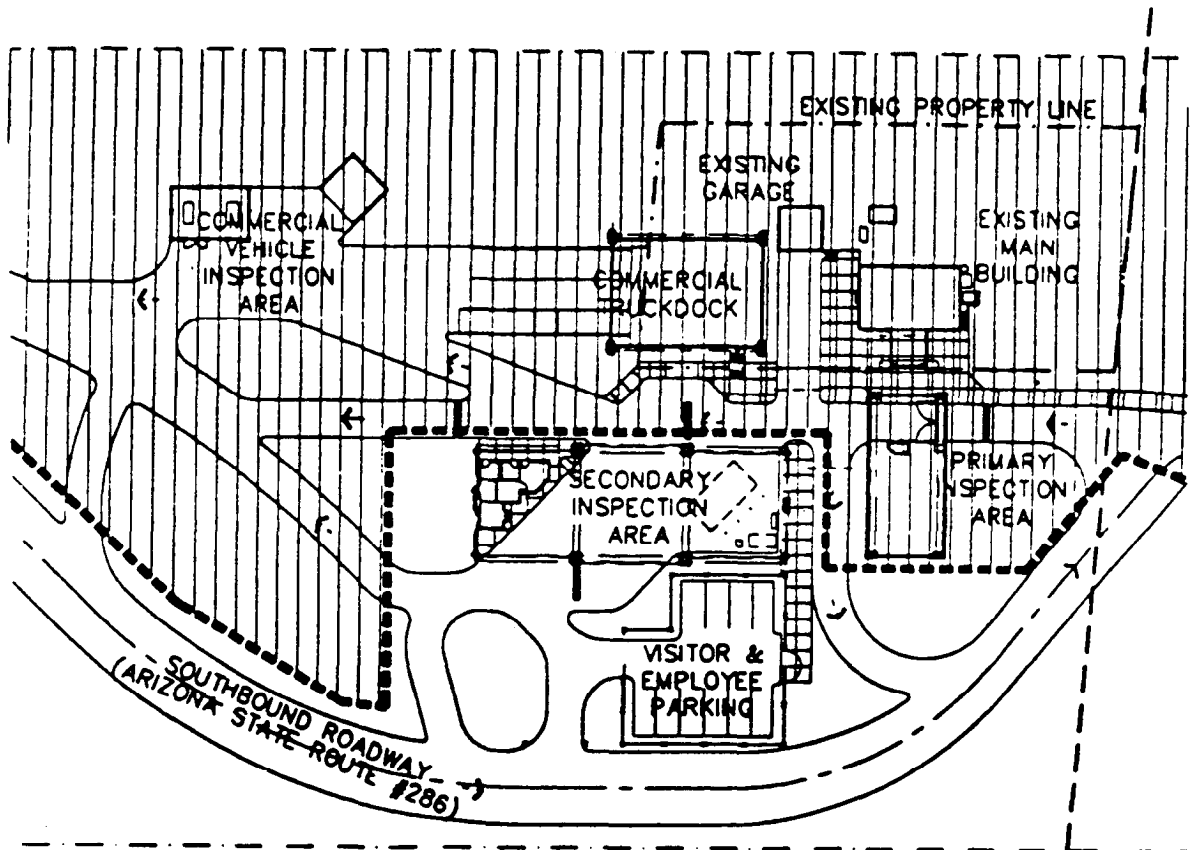

Road Design Data / GSA (continued)

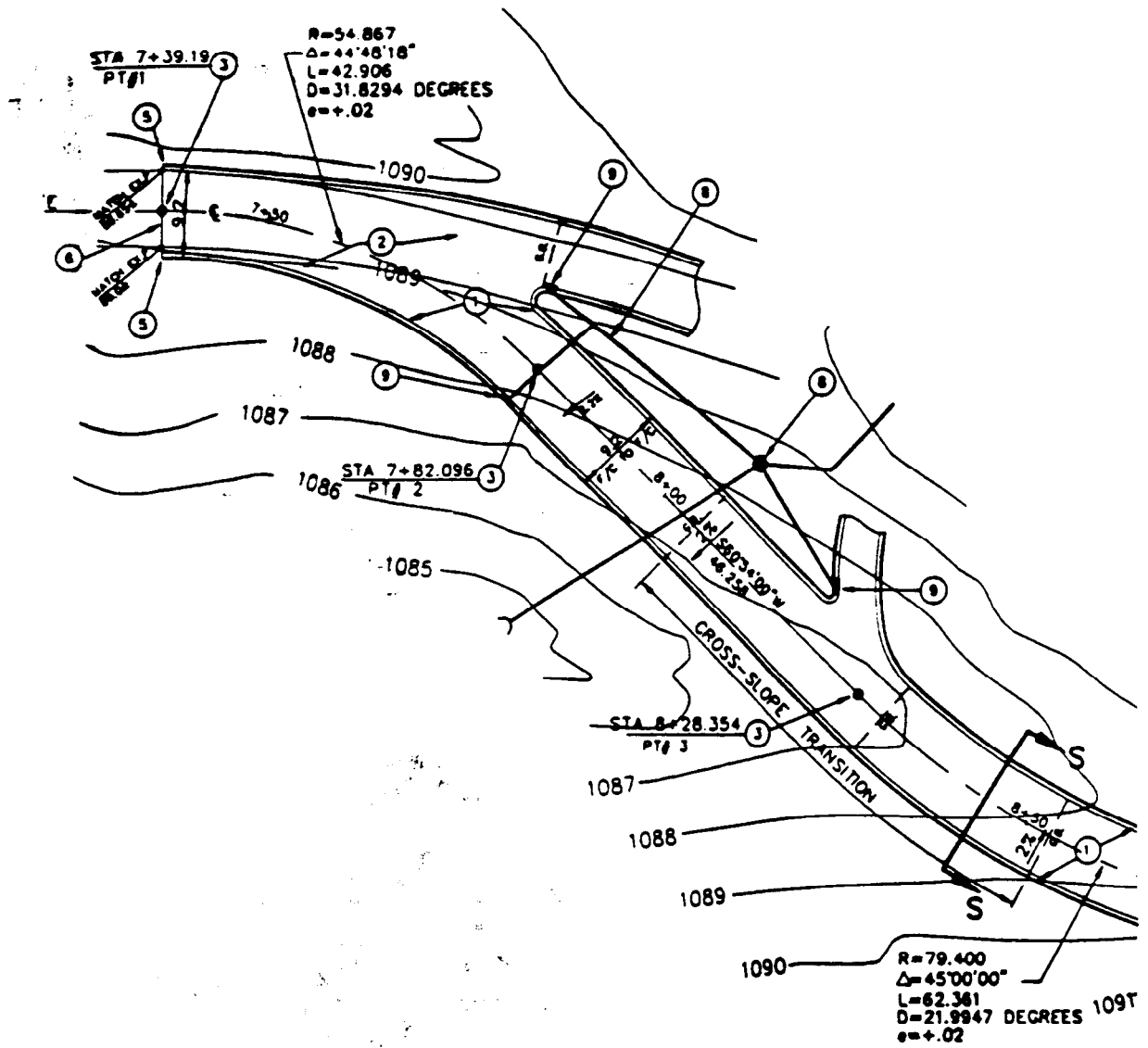

Road Design Data / GSA (continued)

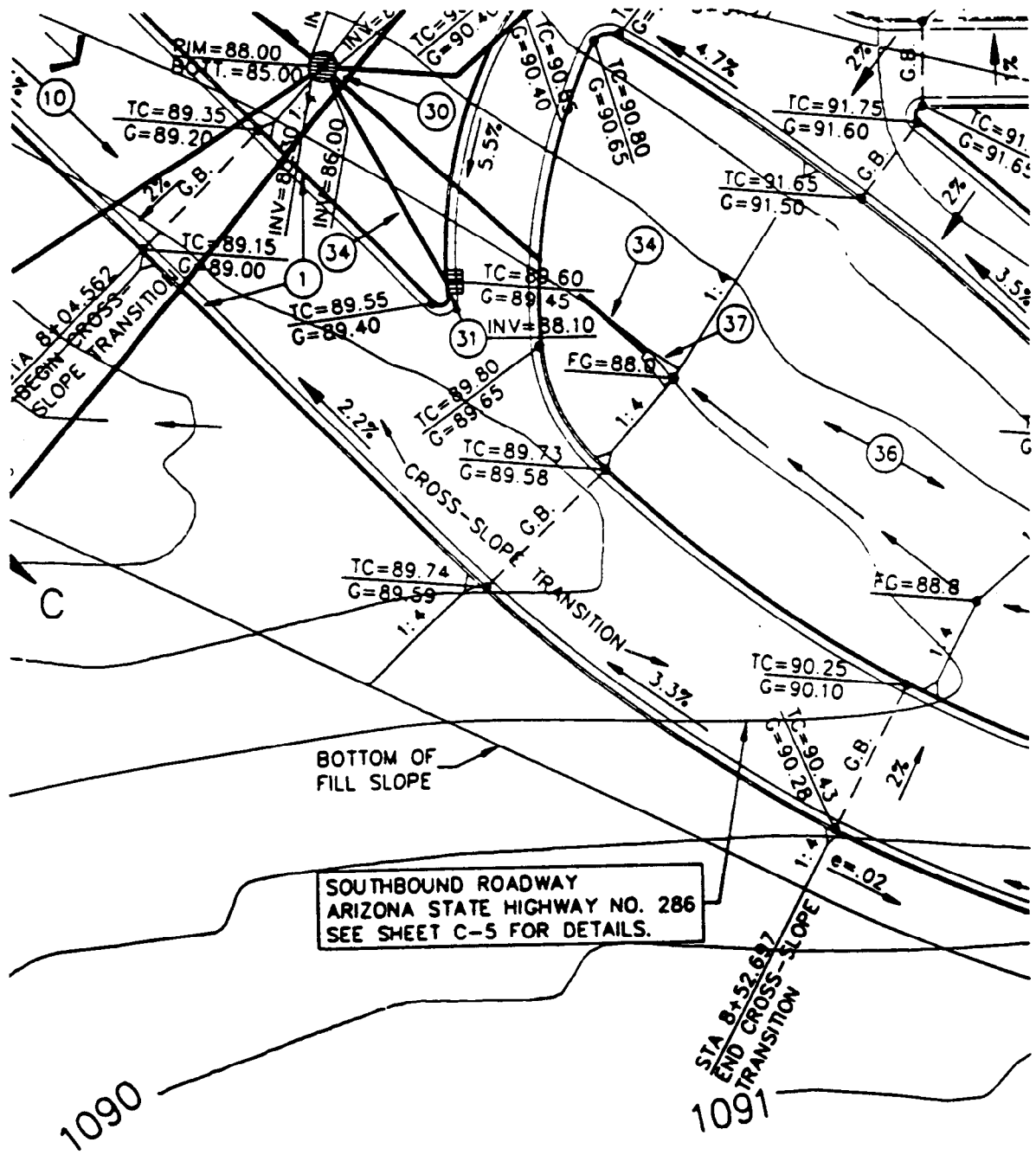

Road Design Data / GSA (continued)

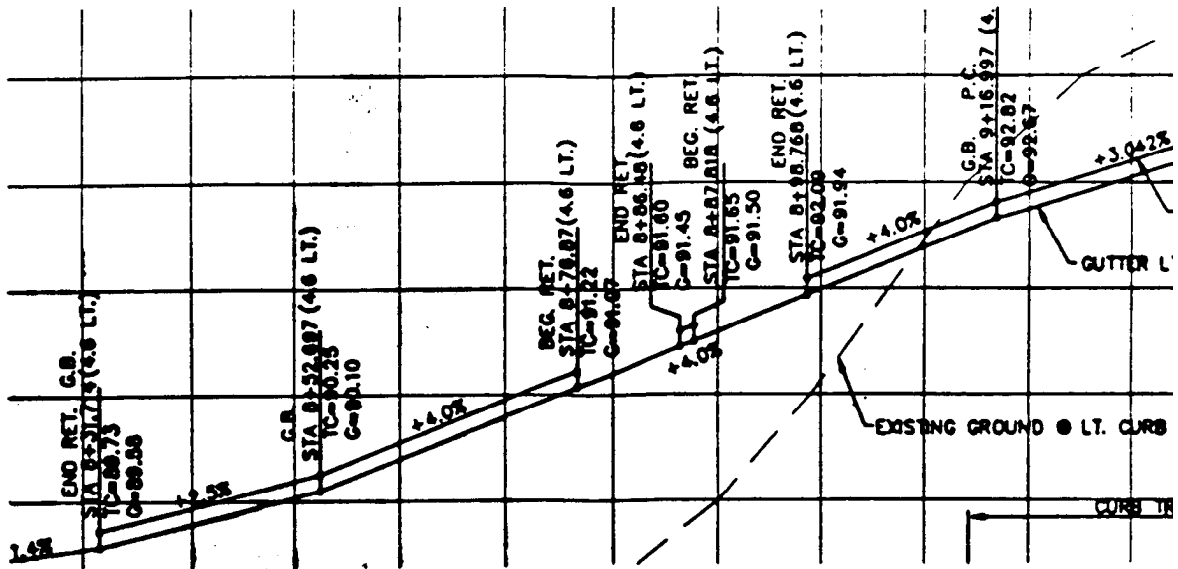
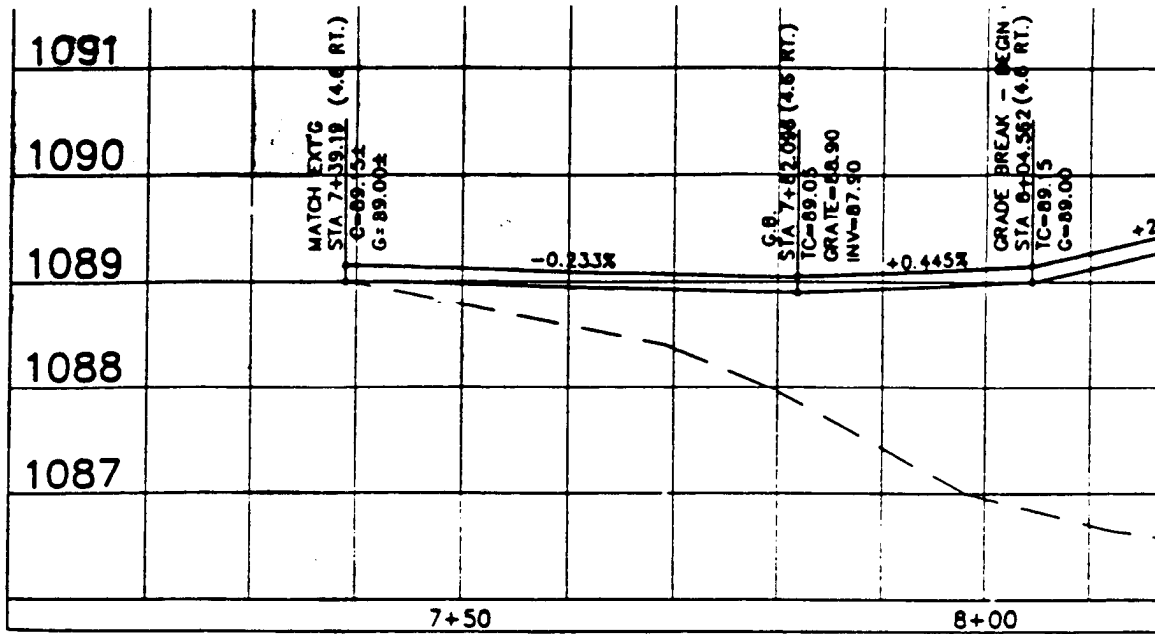

Road Design Data / GSA (continued)

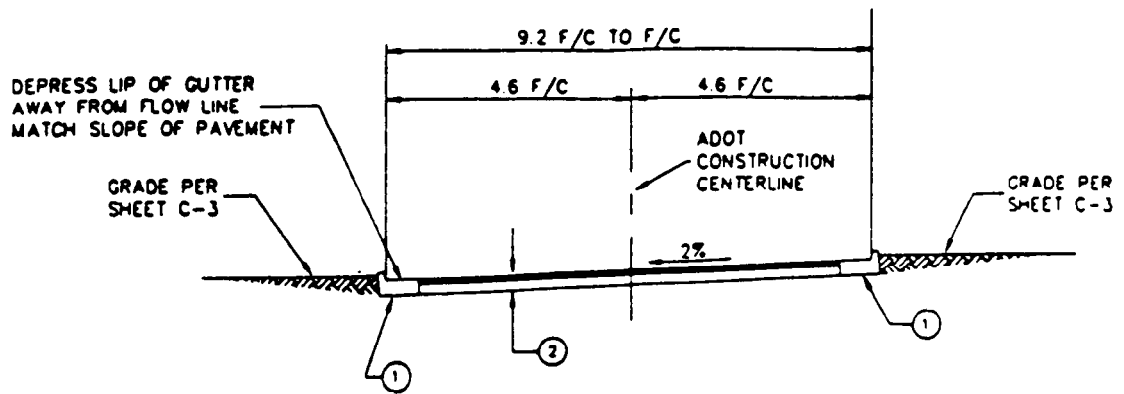

SECTION S-S

SCALE: 1:100

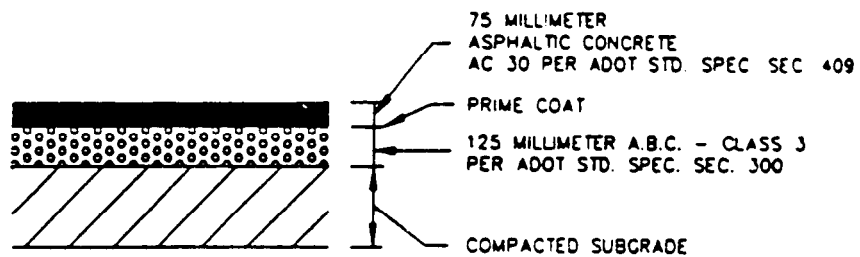

ASPHALTIC PAVEMENT

CONSTRUCTION NOTES:

1. ALL MATERIALS AND CONSTRUCTION FOR THE INSTALLATION OF ASPHALTIC CONCRETE PAVEMENT, ASSOCIATED BASES AND SUBGRADE PREPARATION SHALL BE IN CONFORMANCE WITH A.D.O.T. STD. SPECS. FOR ROAD AND BRIDGE CONSTRUCTION (1990).

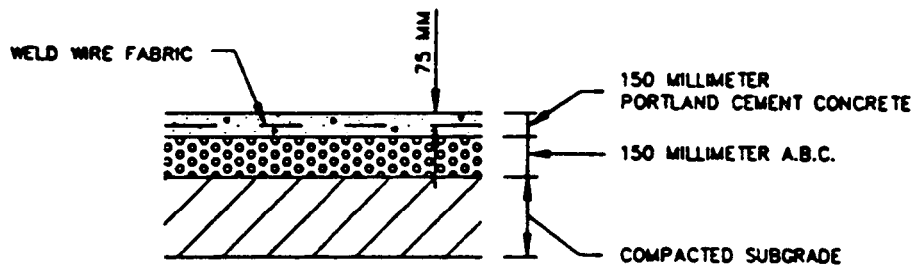

CONCRETE PAVEMENT

Road Design Data / Illinois



Illinois Department of Transportation

Memorandum

~~D. P. Carlson~~ ~~H. D. Ost~~ ~~R. E. Dalton~~
~~D. E. Risinger~~ ~~J. D. Benson~~ ~~R. W. Wright~~
To: ~~M. R. Topel~~ ~~D. L. Klohr~~ ~~Karl Bartelsmeyer~~

From: Thomas R. Bright *T. Ronald A. Bright*

Subject: Minutes of the CADD Metrication Meeting

Date: May 26, 1993

A meeting of the CADD-using organizations was held at the Holiday Inn at Carlinville on May 12 & 13, 1993. Those in attendance are shown on the attached roster.

The purpose of the meeting was to define the impact of IDOT's conversion to metric units on CADD plan preparation and to establish uniform interim working procedures for using metric units until the software programs can be revised to meet IDOT's needs.

Before the Bureau of Information Processing can request the commercial software vendors to make changes in their programs, decisions need to be made by the Division of Highways as to specifications for plan sheet size, plan and profile and cross-section grids, scale ratios, lettering and symbol sizes, stationing conventions and required accuracy of offsets and elevations. The cost and time frame to obtain new programs with the desired specifications will depend to a large extent on the compatibility of IDOT's specifications with those of other DOT's using the same software. Some compromise may be required for the sake of expediency.

The following agreements and conclusions were reached:

DRAFTING AND SURVEYING PRACTICES

- o IDOT will adopt the International Standards Organization sheet size A-1 as our basic plan sheet. The sheet is 594 mm x 841 mm (23.39" x 33.11"). The sheet is commercially available in several plates comparable to the

American Standard Federal Aid sheets including single-plan/profile, double-plan/profile, cross-section and single-plan/cross-section. The profile grid is 2 mm x 10 mm and the cross-section grid is 2 mm x 2 mm. Prints of the sheets were distributed together with the sources of supply. CADD will print its own grid using dotted lines. Subsequent to the meeting, several Districts telephoned to say that the primary vertical grids located 40 mm from the left and right edges of the sheet were of a heavier weight. Presumably, these are where the "match lines" are to be placed which would waste considerable space. It has been decided to locate the match lines 20 mm from the left edge and 10 mm from the right edge. BIP has distributed a CADD generated sheet of the proper configuration to users.

Road Design Data / Illinois (continued)

- o Scale ratios of 1:1000 will replace 1" = 100 ft., 1:500 will replace 1" = 50 ft. and 1:250 will replace 1" = 20 ft. The first two scale ratios are approximately 20% larger than current practice while the last is slightly smaller (1:250 vs 1:240). There was concern that use of a 1:200 scale ratio would result in too large of a detail with insufficient space for notes on the metric-size plan sheets. Vertical cross-section scale ratios of 1:50, 1:100 and 1:250 will replace 1" = 5 ft., 1" = 10 ft. and 1" = 20 ft., respectively.
- o Pavement slope will be shown as a percentage. A slope of 3/16" per ft. = 1.5%, 1/4" per ft. = 2% and 1/2" per ft. = 4%. Superelevation will also be expressed as a percentage rather than m/m using the current rates such as 4%, 6% and 8%. Superelevation rates for the different metric radii and design speeds are being developed along with superelevation transition length and should be available in a month or two. This information can be added to the plans at a later date and no interim procedure will be needed.
- o Not all Districts use the same size lettering template. Current lettering sizes can be soft converted and rounded up to the next mm. Current line weights will be retained.
- o For Standard Plans, details or plan designations, the symbols m², m³, ft² and ft³ will be used in place of the abbreviations cu.ft. or sq.ft. This will require new fonts to be obtained.
- o For surveying, the kilometer station will be used which will require three places after the plus. Tick marks should be shown on the plan centerline at 50 m intervals. Offsets and elevations should be rounded to the nearest 5 mm. Representatives from the Bureau of Bridges and Structures stated that they considered rounding to the nearest 1 mm would be necessary for fillets pier caps and abutment seats. It is questionable that the metric level rod, (E rod) which is graduated in centimeters, can be read to that accuracy. Rounding to larger values will be required in the field.
- o The standard cross-section interval will be 25 m for rural conditions and 10 m for urban conditions. Additional cross sections should be taken as needed to obtain accurate quantities.
- o In converting existing surveys from English units to metric units, the U.S. Survey Foot definition should be used. one foot = 0.30480061 meters or 1 meter = 3.28083333 feet.
- o Some of the Districts are restationing their routes in metric units to facilitate metric plan preparation projects as they arise. The Bureau of Design and Environment has not mandated this action but they do encourage it. It was recommended that restationed routes begin with station 100+000 rather than station 0+000 at the western and southern borders of the Districts to avoid the potential for negative stationing in the event by-passes or extensive relocations are constructed.
- o There will be a problem generating cross sections in metric format when a project has been contoured by the Aerial Survey Section in English units. If the Districts will develop a metric alignment and send it to the Aerial Survey Section, they will read the cross sections photogrammetrically. Considerable "lead time" will be required for this service.

Road Design Data / Illinois (continued)

CADD ISSUES

- o The Geodimeter software only allows two places after the "plus" and the decimal point to denote stationing. The kilometer stationing will require three places for each. BIP will be meeting with the vendor during the week of May 24 to discuss several issues including the provision of three places after the plus and decimal point. District One has done some metric surveying using 100 meter stations to overcome this problem. CADD can shift the plus to three places but the plans and the survey data will not "match up" which could cause some confusion. A team consisting of representatives from Districts 2, 4, 5, 7, and BIP was appointed to develop an interim procedure by mid-June.
- o Tick marks are to be shown on the plan centerline at 50 meter intervals. Geopak currently stations only every 100 meters. The 100 meter interval will be acceptable as an interim procedure.
- o Geopak and other computer programs will not round to the nearest 5 mm. Computers will only round to the nearest tenth, hundredth or thousandth depending on the number of places specified. As an interim procedure, it will be

necessary to round to the nearest 1 mm (even though the accuracy may not be there) and round to the nearest 5 mm in the field for construction. A note could be placed on the cover sheet of the plans and contractors could be reminded to "round" at the preconstruction conference.

- o The seed files will need to be revised. Aerial Surveys is using MU = 1 m, SU = 100 cm/m and PU = 10 mm/cm. BIP suggested using MU = 1 m, SU = 1000 mm/m and PU = 1 mm since values are not to be expressed in terms of centimeters. The first proposal was labeled Alternate B and the second labeled Alternate A. It was the consensus that Alternate A should be adopted. Aerial Surveys had no problem with the decision but reminded the Districts to note that the mapping data they have received to date is in the Alternate B format. Aerial Surveys will change to the Alternate A format for future mapping.
- o Standard working units for cross sections and Geopak will be 1,000 and 100. BIP will revise the user commands.
- o An English file can be referenced to a metric file since a physical object on one file is the same physical object on the other file. Merely select an object and scale around it.
- o Instructions for translating graphic files were issued December 10, 1992 (copy attached). There does not appear to be any problems.
- o Each District will have access to the Standard Plans on CADD. They can use the details but cannot "download" it as a Standard as the signature block would be incomplete.
- o Two methods were discussed for designating metric and English files. The second digit, which currently designates the District, could be used as a designation or the file extension could be changed from .dgn to .dgm or changed from .m32 to .mmm to designate a metric file. The issue was not resolved.

Road Design Data / Illinois (continued)

- o Version 50 of Microstation will no longer have paper menus. BIP will rewrite the menus so they will appear on the screen.
- o BIP will not continue to support ACTEM and ICES. Support will end in June or July of 1993.

LAND ACQUISITION DOCUMENTS

- o Right-of-way plans and plats prepared on CADO will be rounded to the nearest 1 mm as an interim procedure.
- o Plats will have stationing in metric values and offsets in both metric and English units.
- o Metric stationing will be used in legal descriptions even though the remainder of the description is to be expressed in English terms.
- o The Bureau of Land Acquisition is preparing sample metric plats and legal descriptions which will be issued in the near future.

GEOMETRIC DESIGN

- o The December 7, 1992 memorandum from Director Mehner shows a ditch depth of 900 mm and a ditch width of 600 mm. Design and Environment suggested using a 1 m depth but retaining the 600 mm width until the practicality of a 500 mm width could be reviewed by Construction. This would simplify design and construction inspection and would be in the spirit of using more rational metric values where possible. The Bureau of Construction subsequently advised Design and Environment that they foresaw no difficulty in constructing a 500 mm ditch width.
- o The AASHTO recommended values for vertical clearance are 3.8 m (12.46 ft.), 4.3 m (14.10 ft.) and 4.9 m (16.07 ft.). These values were probably selected in part so that the states' existing systems would be in compliance. Design and Environment suggested that for new construction we adopt values of 4 m, 4.5 m and 5 m. These values would simplify design and provide clearance for future resurfacing. The cost would be minimal and again we would be using more rational metric values.

ADMINISTRATION

- o With the slightly smaller metric plan sheet, it may be possible to have an exact 80% reduction on the 11" x 17" "quarter-sized" paper. The print shop will produce an example. This would permit scaling with a standard scale rather than those placed on the cover sheet.
- o It will be necessary to revise the English pay item code numbers to coincide with the section numbers of the new specifications book. These should be available by mid-1994. When the coded pay item numbers were expanded from six digits to eight digits, the fourth field became a zero. It should be possible to designate a metric pay item by deleting the zero and adding an "M" up front or placing a new number in the fourth field. The Bureau of Design and Environment will explore the options.

cc: Directors
Bureau Chiefs
Metric Task Group

Road Design Data / Indiana



INDIANA DEPARTMENT OF TRANSPORTATION
100 North Senate Avenue
Room N735
Indianapolis, Indiana 46204-2249
(317) 232-5533 FAX: (317) 232-8236

PRELIMINARY

GUIDE RECOMMENDATIONS FOR METRIC PLAN PREPARATION

The following guidelines are intended to establish a standard format for preparing metric plans. These standards should be followed whenever possible. In rare instances it may be necessary to deviate slightly from recommended procedures to achieve a desired result. These exceptions should be held to a minimum and used only when sound judgement indicates that a deviation is absolutely necessary.

1. SHEET SIZE AND FORMAT

Metric plan drawing size sheets have been adopted as standard in the conversion from English to metric units. All sheets will conform to the "A1" metric series size. The overall sheet dimensions are 841mm (33.1") wide and 594mm (23.4") high. Drawing borders of 17mm will be used at the top and bottom and 6mm at the right edge. The left border (binding edge) will be 45mm. Until the 841mm metric paper roll width is commonly available we will continue to use the 36" wide paper. The 2.9" excess width will be added to the left (binding edge) border.

The format of all plan and profile, layout, and detail sheets has been changed. The title block has been removed from the lower right corner and has been compressed into a narrow continuous band at the base of each sheet. The title block arrangement is shown on each of the attached example Plan and Profile sheets.

One basic plan and profile sheet has been adopted for use with 1:200, 1:500, and 1:1000 horizontal scales. A profile vertical scale of either 1:50 or 1:100 may be used with this basic sheet. The plan and profile sheets have been modified so that horizontal alignment reference points can be removed from the plan view and placed in the title block area at the bottom of the sheet.

Examples of three plan and profile sheets showing the coverage limits and format for horizontal scales of 1:200, 1:500, and 1:1000 are attached. The 1:500 and 1:1000 scale drawings show the maximum profile coverage (24m at 1:100 or 12m at 1:50). In all three cases, frames with either the top two or top four grid layers removed are available if additional plan coverage is needed. The 1:200 scale sheet illustrates the minimum profile coverage available with the top four grids deleted.

2. STANDARDS FOR STATIONING AND CROSS-SECTIONS

A stationing concept based on one kilometer will be used. For example, Station 12+273.96 indicates a point 273.96 meters forward of kilometer station 12+000.

The survey unit has adopted the practice of using an equivalent conversion from English to metric when re-establishing points from a previously run survey. For example, P. 1. Sta. 456+35 from a 1965 survey using English units would be defined as Kilometer Station 13+909.55 (45635'/3280.84'/km = 13.90955km) in a metric survey. The kilometer stationing on new alignments is arbitrary.

Road Design Data / Indiana (continued)

Standard cross-section intervals of 20 meters should be used where alignment is maintained over existing embankments and thru rolling terrain. Although 20 meters should be considered the standard, a larger interval may be considered when uniform templates are used over flat terrain. Additional cross-sections should be provided to reflect abrupt changes in either the template or the existing ground.

The usual horizontal and vertical cross-section scale is 1:100.

3. STANDARDS FOR ANGLES AND HORIZONTAL CURVES

Angular measurement will continue to be expressed in Degrees, Minutes, and Seconds.

Radius definition of curves will be used rather than Degree of Curve as we currently use. For example, a 3 degree horizontal curve on new alignment (Radius = 1909.86' or 582.125 meters) should be referred to as a 580 meter radius curve. Metric radius on paper relocated horizontal curves should always be expressed in multiples of 5 meter increments.

On the other hand, alignments which incorporate a previously defined horizontal curve should continue to express the radius in meters rounded to the closest 0.005 meters. If the 3 degree curve noted above is a re-creation of a previously established curve, it should be assigned a 582.125 meter radius.

Listed below are three cases defining horizontal curves. In all three cases the curve starts at P. C. Sta 300+59.41 (English) equivalent to P. C. Sta 9+162.110 (metric). Note that metric curve distances are given to the closest 0.005m to retain an accuracy equivalent to 0.01' in English units.

Case A: Normal English curve definition.

Case B: Metric definition assuming that Case A curve data defined the roadway centerline from a previous survey and is to be retained. All curve data is a direct conversion from English to metric.

Case C: Metric definition of a paper relocation starting at P. C. Sta 9+162.110 having approximately the same curvature as the Case A curve. Note that the radius is given in a 5 meter increment.

Case A:	Case B:	Case C:
P. I. Sta = 302+68.57	P. I. Sta = 9+225.860	P. I. Sta = 9+225.630
$\Delta = 12^{\circ} 30'$	$\Delta = 12^{\circ} 30'$	$\Delta = 12^{\circ} 30'$
D = 3° 00'	Rad = 582.125m	Rad = 580.000m
T = 209.16'	T = 63.755m	T = 63.520m
L = 416.67'	L = 127.000m	L = 126.535m

Road Design Data / Indiana (continued)

4. STANDARDS FOR ELEVATIONS AND CONTOUR INTERVALS

The survey unit has adopted the practice of directly converting benchmark elevations from feet to meters. A benchmark elevation of 639.28 feet will be converted directly to (639.28/3.28084'/m=194.585) 194.585 meters. Benchmark elevations should be shown to the closest 0.005 meters to maintain the same accuracy achieved with 0.01' in English units.

When contours are shown on Bridge Layout sheets and other drawings, the contour interval will be 0.2 meters. Each fifth contour representing an even meter elevation (202.0, 203.0, etc.) will be emphasized and annotated. Intermediate 0.2 meter contours will not be annotated unless they represent a high or low contour on the ground surface that cannot be determined by interpolation between adjacent full meter contours.

A 0.2 meter contour interval is equivalent to about 8 inches. This will result in more tightly packed contour lines than have been generated in the past. In rugged terrain or on steep slopes the contour density may interfere with readability. When this occurs, the 0.2 meter contours should be removed from the densely packed areas only. The even meter contours are to be retained in these areas.

5. SURVEY PLOTTING ACCURACY

As a frame of reference, distances expressed in metric units will have the following accuracy in English units:
Closest 0.1 meters will be within 2" of the true distance.
Closest 0.01 meters will be within 3/16" of the true distance.
Closest 0.005 meters will be within 1/8" of the true distance.

With this in mind, survey distances and elevations transferred to plan sheets should be shown as follows:

Horizontal alignment data (curve information, equations, etc.) and Benchmark elevations should be shown to the closest 0.005m.

Roadway elevations, used for pavement tie-ins and vertical clearance computations, should be shown to the closest 0.01m.

All other pluses, offsets, pipe diameters, physical feature dimensions, etc. should be shown to the closest 0.1m.

6. PROPOSED FEATURES ON ROAD PLANS

The location of all proposed features should be shown to the closest one meter, where practical, and never closer than 0.1 meter. The following increments are recommended:

Drive locations-----	Closest 1.0 meters
Culvert locations-----	Closest 1.0 meters
Horizontal ditch grade breaks---	Closest 1.0 meters
Guard rail limits-----	Closest 0.1 meters

Proprietary items, such as pipe sizes which do not yet have a standard metric size, should be converted to meters using a soft conversion and shown on the plans to the next lower 0.01 meter

Road Design Data / Indiana (continued)

increment. This will avoid disputes over the use of material which does not meet the given size if the soft conversion is rounded to the closest 0.01m increment. For example, proposed pipe sizes should be shown as indicated below:

6" diam. = 0.152m	Show as 0.15m
12" diam. = 0.305m	Show as 0.30m
15" diam. = 0.381m	Show as 0.38m
24" diam. = 0.610m	Show as 0.61m
36" diam. = 0.914m	Show as 0.91m

Vertical profile alignment should be shown with P.V.I. Sta. at even 10m increments, V.C. Lengths in 20m increments, and P.V.I. Elevations given to 0.01m increments.

All other vertical elevations (Breaks in ditch grades, pipe invert elevations, etc.) should be shown to the closest 0.1 meters.

7. CROSS SECTION ELEMENTS AND DESIGN DATA

The following information is intended to summarize selected design and detailing "equivalent values" as the transition from English to metric units is implemented.

A. DESIGN SPEEDS:

English value (MPH)	Metric equivalent (Km/h)
30	50 (31.1 MPH)
35 & 40	60 (37.3 MPH)
45	70 (43.5 MPH)
50	80 (49.7 MPH)
55	90 (55.9 MPH)
60 & 65	100 (62.1 MPH)
70	110 (68.4 MPH)

B. CROSS SECTION ELEMENTS:

Lane Widths	Current Value (Pt)	Metric Value (M)
	10	3.0
	11	3.3
	12	3.6
	16	4.8
Shoulder Widths	4	1.2
	6	1.8
	8	2.4
	10	3.0
	11	3.3

Always maintain lane and shoulder widths in 0.1 meter increments.

C. GUARD RAIL DIMENSIONS:

The offset from the face of guard rail to the shoulder break (formerly 3'-3") will now be 1.0 meters as shown in the sketch on the following sheet.

Road Design Data/Indiana (continued)

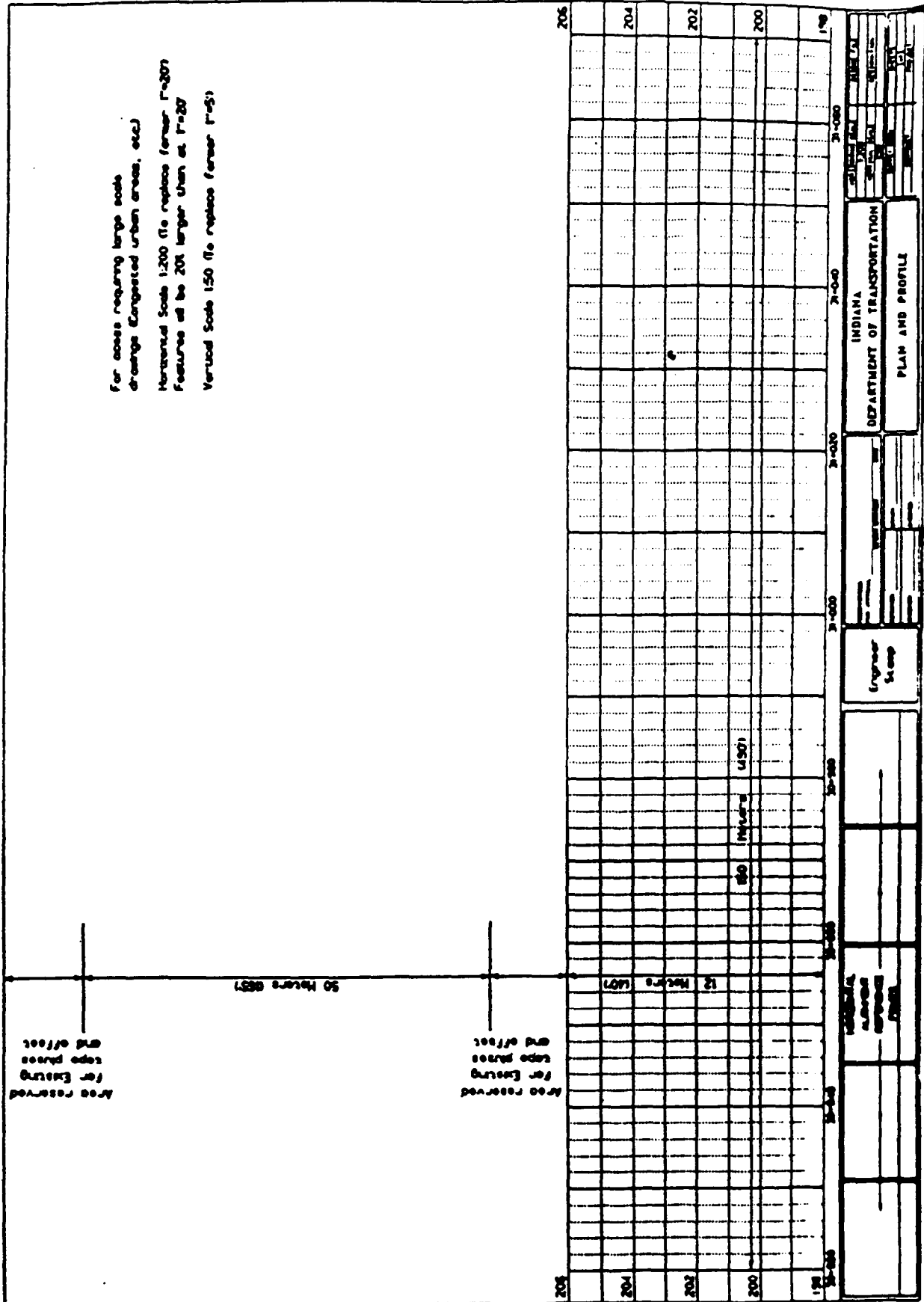

Road Design Data / Indiana (continued)

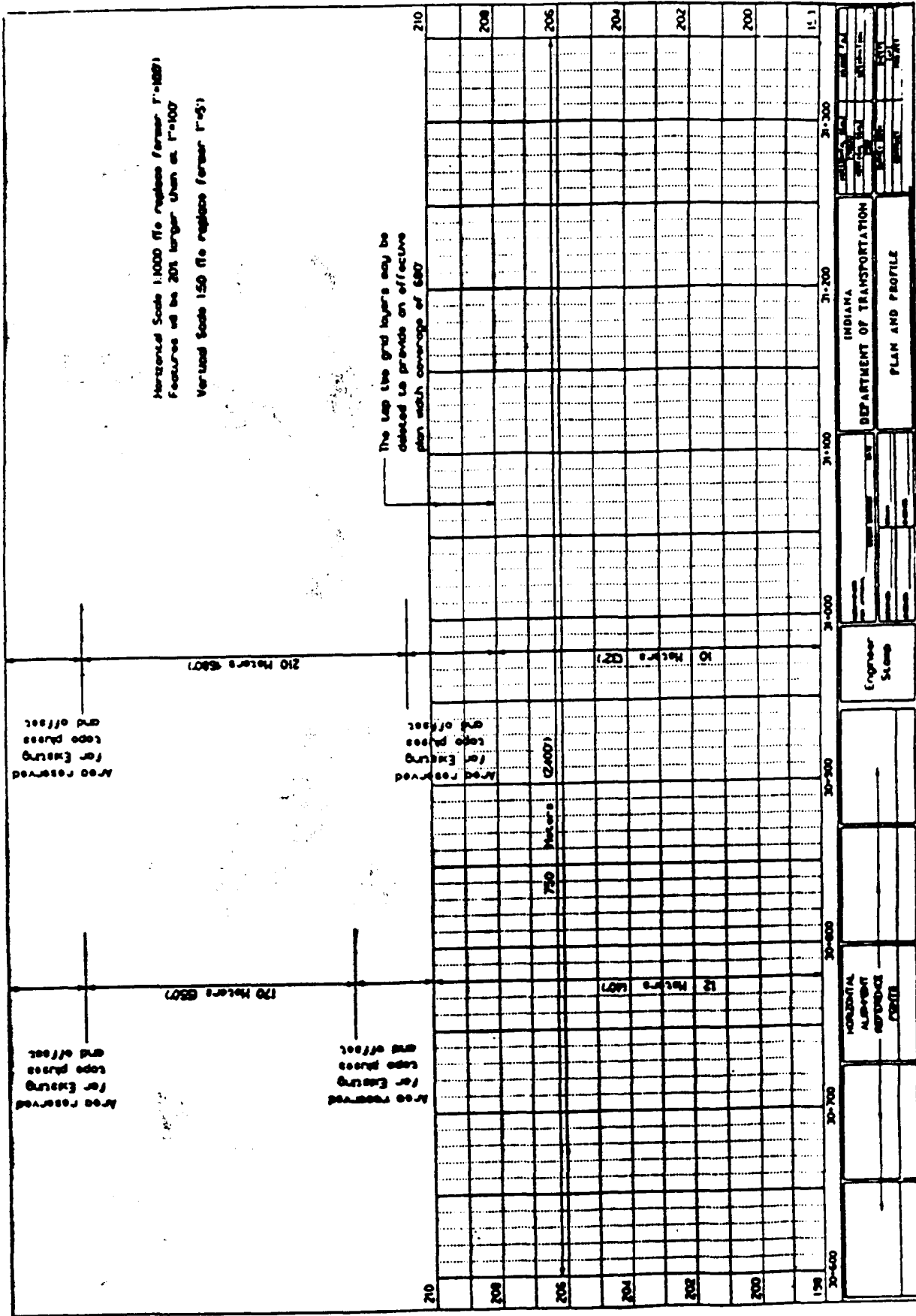

Road Design Data / Indiana (continued)

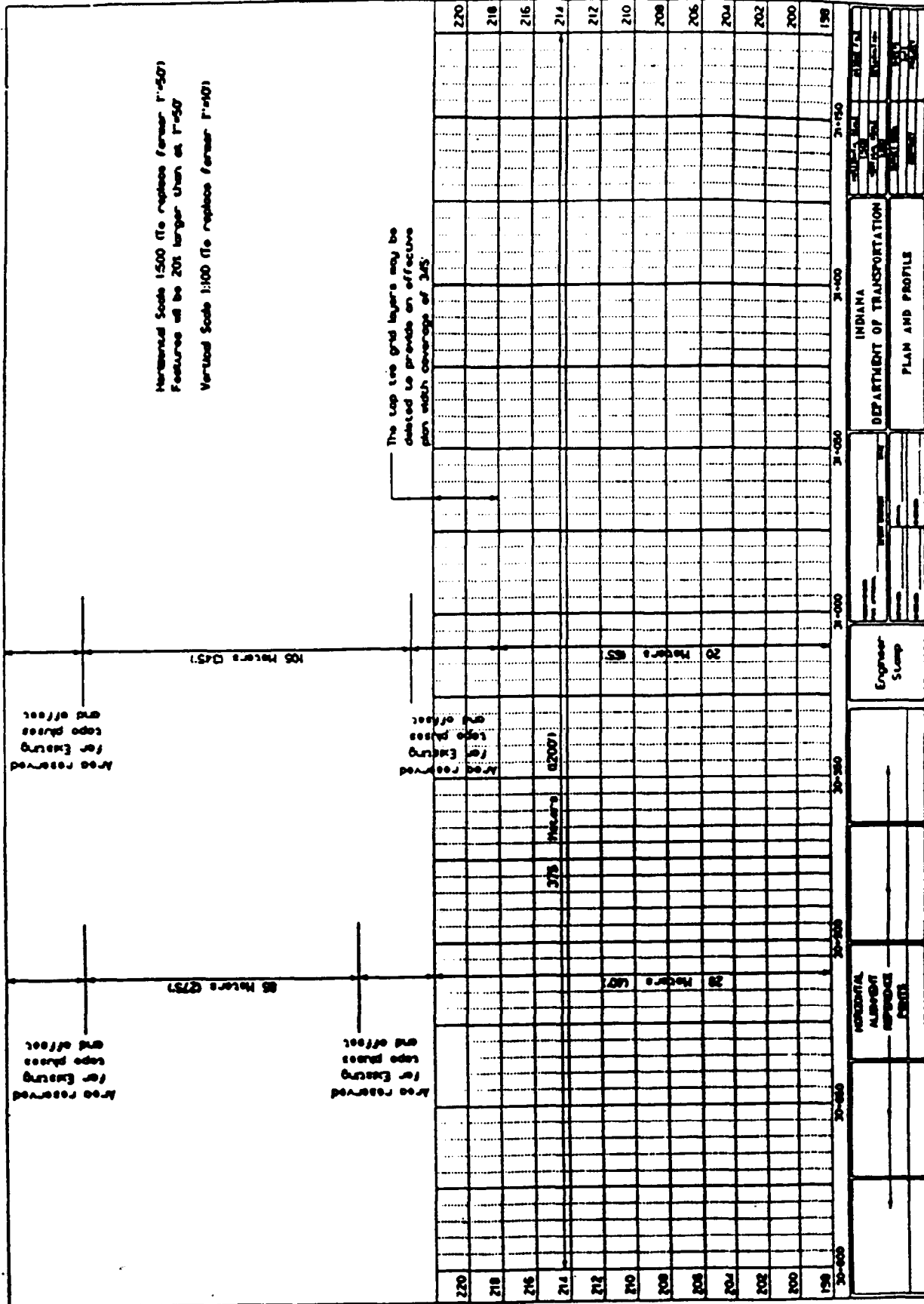

Road Design Data / Kentucky



COMMONWEALTH OF KENTUCKY
TRANSPORTATION CABINET
FRANKFORT, KENTUCKY 40622

TABLE S-4

KENTUCKY DEPARTMENT OF HIGHWAYS BASIC GEOMETRIC DESIGN CRITERIA URBAN ROADWAYS (OTHER THAN FREEWAYS)			
	URBAN LOCAL STREETS	URBAN COLLECTOR STREETS	URBAN ARTERIAL STREETS
DESIGN SPEED	MIN. 30 K.M./H. DES. 50 K.M./H.	MIN. 50 K.M./H. DES. 60 K.M./H.	MIN. 50 K.M./H. DES. 100 K.M./H.
NUMBER OF LANES	MINIMUM 2	MINIMUM 2 (4)	MINIMUM 2 (4)
LANE WIDTH (METERS)	RESIDENTIAL: MIN. 2.7 - DES. 3.3 (1) COMMERCIAL: MIN. 3.0 - DES. 3.3 INDUSTRIAL: MIN. 3.3 - DES. 3.6 (2)	MIN. 3.0 - DES. 3.6 (2) MIN. 3.3 - DES. 3.6 (3)	AS FREE FLOW CONDITION (2) 3.3 MIN. INTERRUPTED FLOW CONDITION (2)
SIDEWALK WIDTH (METERS)	RESIDENTIAL: MINIMUM 1.2 COMMERCIAL: DESIRABLE 2.4		
MINIMUM CLEAR ROADWAY WIDTH OF NEW AND RECONSTRUCTED BRIDGES	MIN. CURB TO CURB WIDTH		
BORDER AREA (METERS)	MIN. 1.5 - DES. 3.0	MIN. 2.4 - DES. 3.3	MIN. 2.4 - DES. 3.6
EARTH CUT FILL SLOPE RATIO	2:1 MINIMUM - 4:1 OR FLATTER DESIRABLE		
CURVATURE (MINIMUM RADIUS IN METERS)	2:1 MINIMUM - 4:1 OR FLATTER DESIRABLE		
MAXIMUM GRADE (IN PERCENT)	MINIMUM 10m (6)		
MINIMUM STOPPING SIGHT DISTANCE (METERS)	MINIMUM 30m (2)		
NORMAL PAVEMENT CROSS SLOPE	MINIMUM 30m (2)		
NORMAL SHOULDER CROSS SLOPE	MINIMUM 30m (2)		
SUPERELEVATION	MINIMUM 30m (2)		

(1) - RESIDENTIAL
 (2) - COMMERCIAL
 (3) - INDUSTRIAL
 (4) TURNED LANES - 2.7m MINIMUM - 3.6m DESIRABLE
 PARKING LANES - RESIDENTIAL - 2.7m MINIMUM - 3.6m DESIRABLE
 COMMERCIAL & INDUSTRIAL - 2.7m MINIMUM - 3.6m DESIRABLE
 (5) TURNED LANES - 3.0m MINIMUM - 3.6m DESIRABLE
 PARKING LANES - 2.7m MINIMUM - 3.6m DESIRABLE
 (6) STEEP-FACED CURBS (MINOR OR MINOR ADJACENT TO MAJOR TRAFFIC LANES) SHOULD BE OFFSET AT LEAST 0.6m FROM THE EDGE OF A CONCRETE CURB AND GUTTER CONSTRUCTION. THE GUTTER-PAN WIDTH, NORMALLY 0.6m, SHOULD BE USED AS THE OFFSET DISTANCE.
 THE NUMBER OF LANES TO BE PROVIDED ON STREETS WITH A CURRENT SET OF SIGNAL SIGNALS FOR DAY OR NIGHT SHOULD BE DETERMINED BY HIGHWAY CAPACITY ANALYSIS OF THE DESIGN TRAFFIC VOLUMES. DESIRABLE, SUCH ANALYSIS SHOULD BE MADE FOR FUTURE DESIGN TRAFFIC.
 (7) THE BORDER IS THE AREA BETWEEN THE ROADWAY AND THE RIGHT OF WAY LINE THAT SEPARATES THE TRAFFIC FROM THE HOMES AND BUSINESSES OF THE COMMUNITY. TO BE DETERMINED ON PROJECT TO PROJECT BASIS.
 (8) MINIMUM STOPPING SIGHT DISTANCES ARE BASED ON HEIGHT OF EYE OFFERS AND HEIGHT OF OBJECT CROSS, BOTH HORIZONTAL AND VERTICAL ALIGNMENTS CONSIDERED.
 (9) NORMAL PAVEMENT CROSS SLOPES ON BRIDGES SHALL BE AS
 (10) ON ARTERIALS HAVING LARGE NUMBERS OF TRUCKS AND OPERATING NEAR CAPACITY GRADES FLATTER THAN THOSE IN RURAL SECTIONS SHOULD BE CONSIDERED TO AVOID UNDESIRABLE RESTRICTIONS IN SPEEDS.
 (11) SUPERELEVATION IS NOT REQUIRED ON LOCAL STREETS IN RESIDENTIAL AND COMMERCIAL AREAS.
 (12) FOR URBAN ROADWAYS WITH SHOULDERS AND NO CURBS, THE CLEAR ROADWAY WIDTH SHOULD BE IN NO CASE LESS THAN NOTING SHOWN FOR RURAL ROAD FUNCTIONAL CLASSIFICATION.
 (13) WHERE CURVES ARE SUPERELEVATED, LOWER VALUES MAY APPLY, BUT THE RADIUS SHOULD NEVER BE LESS THAN 200m FOR A 30 K.M./H. DESIGN SPEED.
 (14) MINIMUM GRADES OF SHORT LENGTHS LESS THAN 60m AND ON ONE-WAY DOWN GRADES MAY BE ONE PERCENT STEEPER.
 (15) 3.0m WIDTHS MAY BE USED IN HEAVILY RESTRICTED AREAS HAVING LITTLE OR NO TRAFFIC.
 (16) FOR CLEARANCE ON FREEWAYS, REFER TO AASHTO, A POLICY ON GEOMETRIC DESIGN OF FREEWAYS AND STREETS.

Road Design Data / Louisiana



NO COPY KEPT IN
FILE NO.

DEPARTMENT OF TRANSPORTATION AND DEVELOPMENT
INTRADEPARTMENTAL CORRESPONDENCE

July 2, 1993
(504)379-1309

- _____ RECOMMENDED FOR ACTION
- _____ ANSWER FOR MY SIGNATURE
- _____ FOR FILE
- _____ FOR YOUR INFORMATION
- _____ FOR SIGNATURE
- _____ RETURN TO ME
- _____ PLEASE SEE ME
- _____ PLEASE TELEPHONE ME
- _____ FOR APPROVAL
- _____ PLEASE ADVISE ME

METRIC CONVERSION GUIDELINES

SEE PP 2 & 4

MEMORANDUM NO. 81

BY _____ DATE _____
BY _____ DATE _____
BY _____ DATE _____

MEMORANDUM TO ALL DESIGNERS & CONSULTANTS

1. **MEMORANDUM TO THE FILES:** Attached is a copy of my June 4, 1993 memorandum to the files which outlines various guidelines that were adopted at a recent metric design meeting. As a follow-up to item 5 in those minutes, at a subsequent meeting it was tentatively decided to detail R/W maps using Metric units only, with the single exception that the areas shall have the equivalent English unit shown in parentheses.
2. **MISCELLANEOUS INFORMATION:**
 - a) **DESIGN:** It is anticipated initially that design will continue in English, with detailing in metric, however, the advent of metricated AASHTO Bridge Specifications in the future may eventually force us to design in metric.
 - b) **SOFTWARE:** External software will likely be converted "automatically" since its vendors serve a national market. There does not appear to be any hurry to convert internal software. A quick fix for conversion would be to add input & output conversion modules, however this may hamper future efforts to update programs with future Metric AASHTO Bridge Specifications, and may also cause roundoff errors.
 - c) **STRUCTURAL STEEL:** Since there is presently no international standard for structural steel shapes, soft conversion will be utilized nationally, i.e., there will be no physical change in the structural shapes, but their section properties shall simply be specified in metric. The new steel manual should be available within a year, but in the interim, I have copies of the following metric steel publications: STANDARD METRIC DIMENSIONS (USS), METRIC PROPERTIES OF STRUCTURAL SHAPES (AISC), LRFD SPECIFICATION FOR STRUCTURAL STEEL BUILDINGS (AISC).

RECOMMENDED FOR APPROVAL _____ DATE _____
RECOMMENDED FOR APPROVAL _____ DATE _____

Road Design Data / Louisiana (continued)

Memorandum No. 81
 July 2, 1993
 Page 2

- d) **BOLTS:** Structural steel bolts will be hard converted in metric, but allowing for the substitution of English bolts. It appears that we should specify the M22 bolt almost exclusively which compares very favorably with our current 7/8" bolt (see below):

<u>Bolt</u>	<u>Bolt Diameter</u>	<u>Hole Diameter</u>	As you will note, a 7/8" bolt could be substituted without any check, since the hole would require no modification, and the bolt size is slightly larger.
7/8"	22.2 mm	23.8 mm	
M22	22 mm	24 mm	

- e) **REBAR:** Reinforcing steel should be hard converted, with bar sizes being expressed in the format *xyyy*, where *xx* is the nominal bar diameter (mm), and *yy* is the number of the bar according to its location. For example, a 15 mm bar would be specified as a 1501 bar (presently a 501 bar, see below). The bar sizes are shown in ASTM A-615M, which is the metric counterpart for ASTM A-615. Below is a comparison of bar sizes.

<u>Metric</u>	<u>d (mm)</u>	<u>A (mm²)</u>	<u>A (in²)</u>	<u>English</u>	<u>A (in²)</u>
- 10	11.3	100	0.16 *	4	0.20
- 15	16.0	200	0.31 *	5	0.31
20	19.5	300	0.47	6	0.44
				7	0.60
- 25	25.2	500	0.78 *	8	0.79
30	29.9	700	1.09	9	1.00
				10	1.27
- 35	35.7	1000	1.55 *	11	1.56
45	43.7	1500	2.33	14	2.25
55	56.4	2500	3.88	18	4.00

SUBSTITUTIONS: Note that for certain size bars (denoted by *) English substitutions could be used without a check. A general note could be added to allow "blanket" substitutions for the 4 bar sizes noted above, however, for other sizes further evaluation may be needed before setting a policy. English substitutions allowing the respacing of bars to equalize the total area may not be practical, as this would be cumbersome to check during construction, and, therefore, might compromise quality assurance.

- f) **PIPE:** It appears that since there is presently no international standard in pipe size that soft conversion will be utilized, with only the section properties specified in metric.
3. **METRIC EQUIPMENT:** The following equipment has been, or will be purchased, and will be distributed initially as shown on the attachment. Additional orders will be made as they are needed.
- a) Metric scales (2): 1:100, 1:200, 1:300, 1:400, 1:500, 1:600
 1:2.5, 1:5, 1:10, 1:20, 1:50, 1:100

Road Design Data / Louisiana (continued)

Memorandum No. 81
July 2, 1993
Page 3

- b) Metric calculator (Sharp EL-344G)
- c) Green book metric interim (to be ordered)
- d) Set of curves (?) This is a problem. Whereas the old curves specified various degrees of curvature based on a scale of 1" = 100', the new curves are based on actual millimeter radii for a 1:1 scale. This creates a problem in that there generally will not be a curve to fit the particular radius needed. See example below:

Assume a scale of 1:600 (1" = 50'), and that you want to draw a 500 M radius curve. This computes as follows:

$500/600 = 0.833$ M or 833 mm. From the table below, you can see that the closest curves would be R = 800 or 850 mm.

RADII OF METRIC CURVES

<u>Increment</u>	<u>From</u>	<u>To</u>
10 mm	100 mm	200 mm
20 mm	200 mm	400 mm
50 mm	400 mm	1000 mm
100 mm	1000 mm	2000 mm
250 mm	2000 mm	5000 mm

A table has been prepared to show the actual mm radii for the English curves which may prove just as useful as the metric curves. Mr. Hickey advised that a set of metric curves is around \$500.

- 4. PRESTRESSED GIRDERS: An effort is being made to achieve a consensus among several states as to the new metric sections that will eventually replace our current English AASHTO shapes. It is anticipated that fabricators will metricate by attrition, as old forms wear out they will be replaced by new metric forms. Two goals that should be met in establishing metric shapes, is that the overall height and the section properties should remain essentially the same, whereas the width and incremental dimensions are more flexible. If sufficient equivalency of section properties can be achieved, then it may be possible to allow the current English shapes as substitutions without requiring any checking. In addition, the strands will not physically change size, as, currently, metric strands are the same size as the English ones we presently use. In order to be compatible with equivalent section properties, the strands could be spaced at "equal spaces" to sum to a total metric rounded out-to-out of strands, rather than rounding the individual 2" spaces which would lead to cumulative roundoff error.

Road Design Data / Louisiana (continued)

Memorandum No. 81

July 2, 1993

Page 4

5. COORDINATION: As a reminder to all coordinators, all future projects which are initiated should be in metric. Therefore, any future surveys or feasibility studies that haven't commenced, including any that may presently be in negotiation, should be performed in metric units. Instructions will be forthcoming concerning projects which are presently in design and likely to be let after September 1996.
6. PRIORITIES: The first priority in gearing up for metric conversion is to begin updating the standard plans. The most often used standards should obviously be targeted first, such as general note sheets, CS-216, slab spans, BR-01 & 02, guardrail, miscellaneous span & girder, etc. In converting the slab spans, an attempt will be made to utilize varying dimensions with bar and quantity tables to handle variations within a series.

NORVAL P. KNAPP
BRIDGE DESIGN ENGINEER

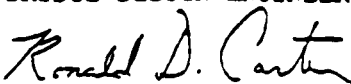
RONALD D. CARTER
CHAIRMAN, METRIC COMMITTEE

RDC

cc: Mr. Al Dunn
Mr. Terry Shaw
Mr. Nick Kalivoda III
Mr. Glenn Chustz

Road Design Data / North Carolina



STATE OF NORTH CAROLINA DEPARTMENT OF TRANSPORTATION

JAMES B. HUNT JR.
GOVERNOR

DIVISION OF HIGHWAYS
P.O. BOX 25201, RALEIGH, N.C. 27611-5201

SAM HUNT
SECRETARY

January 25, 1993

MEMORANDUM TO: CADD Standards Policy Committee:
Mr. Danny Burwell, PE; Mr. Rennie Lovisa, PE
Mr. Cecil Hinnant; Mr. Bob Brown, PE

FROM: Tom Shearin, PE *TS*

SUBJECT: CADD Metrication Issues

This Standards Policy Committee met on 1/21/93 to review and approve various metric recommendations as proposed by the Standards Working Committee. Steve Manilla, Harry Thompson, Charlie Brown also participated in the meeting. Jimmy Norris presented the following items as basic CADD elements which must be established in order to begin the metrication process in Location, Photogrammetry, Design Services, Engineering Automation and Roadway Design. Under a separate letter of January 25, 1993, Mr. Jimmy Norris has distributed a detailed report of these metric implementation recommendations. These items were approved by the CADD Standards Policy Committee on 1/21/93 as follows:

1. Working Units of 1:1000:4 were approved with the global origin in the lower left corner. This will permit full metric coordinate coverage with the State Plane System in one file. See attachment #1.
2. Alignment stationing will be based on the kilometer as the basic station as recommended by AASHTO. The alignment will be tick marked every 100 meters. The station annotation format will read 1+234.567, which provides millimeter accuracy. Alignment will be provided in this format by Location, Photogrammetry and Roadway Design.
3. The standard interval for the spacing of cross-sections will be 20 meters. Upon special request to Location and/or Photogrammetry, the spacing can be set at 5, 10, 40, or 50m in special situations as needed by Roadway or Design Services.
4. Plan Sheet Sizes
Currently our plan sheets are 36" (914.4mm) by 22" (559mm) full length and width of the paper sheets. We will continue with this current overall paper size since we have it in stock until official metric sized sheets are established. We are adjusting the inside borders to set the drawing area boundaries to metric

Road Design Data / North Carolina (continued)

dimensions of 860mm by 530mm. The standard interchange detail sheet will continue to be 36" (914.4mm) by 72" (1829mm) for the full width and length of the sheets. The inside borders will be revised to provide metric dimensions of 890mm by 1730mm. These dimensions will be utilized by Photogrammetry, Location, Roadway Design and Design Services. We recommend that all other Units/Branches (i.e. Traffic Engineering, Structure Design, Roadside Environmental, Geotech, Divisions) adopt this as a uniform standard for all of NCDOT/DOH.

5. Photogrammetry provided recommendations for metric mapping guidelines as listed in attachments #2 and #3.

Metric Plan Sheets

The basic plan sheet metric "scale" will be the 1:500 ratio. This translates to approximately 1 inch=40 feet scale in the English system. This 1:500 ratio was approved as our standard plan sheet scale. For dense urban areas, a 1:250 metric ratio (apprx. 1"=20') will be available upon request from Photogrammetry. Also a 1:1000 ratio (apprx. 1"=80') will be provided if needed. See Attachment #2 for additional plan sheet items.

All plan sheets will have a scale bar to clearly show the ratio/scale of each sheet. This bar scale will also be applicable when the sheets are reduced or enlarged.

Metric Mapping

Photogrammetry's planimetric and topographic mapping guidelines are listed on Attachment #3.

Both planimetric and topo mapping scales will be as needed for specific applications:

- 1:2500 (apprx. 1"=208')
- 1:1000 (apprx. 1"=80')
- 1:2000 (apprx. 1"=160')

Grid lines will be spaced at 200mm intervals (8"+/-) independent of the scale. All map sheets will have a bar scale and a note stating the use of metric values.

Contours will be 0.5, 1.0 or 2.0m as requested in specific applications.

Uncontrolled Mosaic Photos

The following scales will be available upon request:
1:1000; 1:2000; 1:5000; 1:10,000; 1:20,000; 1:50,000.
All mosaics will have a metric scale bar.

6. Mapping/plan sheet labeling by Photogrammetry and Location. Attachment #4 lists the basic metric dimensions (m or mm) which will be used to label various basic topo features. The measurement of numerous items could be confusing as to whether they should be described in meters or millimeters. (Note:

Road Design Data / North Carolina (continued)

centimeters will not be used in highway applications) It is essential that consistency be established whether the meter or millimeter is selected as the defining measurement in the items such as topo features, pay items, pipe sizes, mapping labels, etc.. Therefore, rather than develop a master list to select a or mm for each and every item, a basic "rule of thumb" will be used in our metric conversion.

- * If the item or feature is currently listed in feet and is greater than a meter, it will be measured in meters (e.g. a 5' sidewalk will be 1.5m sidewalk). Also if an item is now described in feet and is less than a meter, it will be listed in millimeters (e.g. 2'-6" concrete curb & gutter will become 750mm concrete curb & gutter).
- * If the item (e.g. 48" fence) is now described in inches, it will be listed in metrics as millimeters (1200mm fence).
- * Our present "inch" pipe sizes will be translated to a "nominal" metric values (a rounded approx. value) in millimeters. These nominal pipe sizes should be established by the Hydraulics Unit in coordination with the industry.

These rules will also apply to pay item descriptions. Generally, if a pay item is paid for by linear feet it will be paid in meters; cubic yards will be in cubic meters, inches items will be paid in millimeters. The full pay item descriptions will be set by the Design Services Unit at a later date.

7. As previously discussed, a scale bar will be shown on all mapping, mosaic photographs, plan sheets and cross-section sheets.
8. A note will be shown on the title sheet as follows:
"All dimensions are in meters and or millimeters unless otherwise shown".
9. A metric grid pattern was approved for use in the pilot projects for cross-sections and profile sheets.
10. A "Drainage Summary Sheet" was approved for use in Roadway Design with metric values.
11. The Committee discussed some legal questions which must be addressed in the metric applications involved with recording R/W plans and condemnation maps in the Court system. Staff from Location, Roadway, Design Services, R/W and the Attorney General meet on 1/21/93 to initiate discussions on these issues. Mr. John Maddrey of the AG's staff was not aware of any legal requirements which prohibited the use of metrics in our mapping, R/W agreement or plans; however, he anticipates considerable opposition by individual judges, attorneys and the general public due to the initial confusion of metric terms. John will investigate in more detail the current legal issues involved, particularly in the condemnation map process.

The CADD Standards Policy Committee would like to express appreciation to the members of the Standards Working Committee for their efforts in investigating these metric issues and then preparing the solutions in a very short time period. Some of these items may need to be revised/adjusted as we progress and learn from our metrication efforts; however, these basic decisions should provide a solid foundation for our CADD applications in metrics.

GTS

Attachments

cc: Mr. D. R. Norton, PE
Mr. John Smith, PE
Mr. A. L. Hankins, PE
Mr. Bill Moore, PG
Mr. Steve Manilla, PE
Mr. Harry Thompson, PE
Mr. Bryce Clodfelter
Mr. Linwood Stone, PE
Mr. Troy Peoples, PE
Mr. Bob Pearson, PE
Mr. Jimmy Norris

Road Design Data / North Carolina (continued)

PROPOSED METRIC MAPPING GUIDELINES

In order to provide mapping using the SI system of measurement (metric), various items have to be addressed for this to be accomplished. These items are identified below for Plan Sheets, Planimetric Mapping, Topographic Mapping, and Uncontrolled Photo Mosaics.

PLAN SHEETS

SCALES - Used for
Plan Sheets will be :

1:500	Primary
1:250	Other scales which could be used
1:1000	

ALIGNMENTS

- 1 km stationing shown to the millimeter
ex. 1 + 000.000
- Tick marks shown every 100 m with station label

CROSS SECTIONS

- 20 m interval for typical preliminary X-sections
- Other intervals as requested

LABELS

- See attached chart for dimensioning

CONTOURS

- 0.5 m or 1.0 m contour intervals could be used

All Title Sheets will need a statement that the units of measure are either meters or millimeters unless otherwise noted. A scale bar must also be located on each Plan Sheet.

Attachment 2

Note: Attachment 1 (Not Included)

Road Design Data / North Carolina (continued)

PROPOSED METRIC MAPPING GUIDELINES

PLANIMETRIC MAPPING

SCALES

- 1:1000 For dense urban areas
- 1:2000 For rural areas
- 1:2500 For rural areas

GRID

- 200 mm grid interval
ex. 500 m at 1:2500; 400 m at 1:2000; and 200 m at 1:1000

CROSS SECTIONS

- Cross section intervals as requested

LABELS

- See attached chart for dimensioning

TOPOGRAPHIC MAPPING

SCALES

- 1:1000 For dense urban areas
- 1:2000 For rural areas
- 1:2500 For rural areas

GRID

- 200 mm grid interval
ex. 500 m at 1:2500; 400 m at 1:2000; and 200 m at 1:1000

CONTOURS

- 0.5 m, 1.0 m, or 2.0 m intervals where required

LABELS

- See attached chart for dimensioning

Both Planimetric and Topographic mapping will need a statement that the units of measure are either meters or millimeters unless otherwise noted. A scale bar must also be located on each map.

Road Design Data / North Carolina (continued)

METRIC DIMENSIONING FOR EXISTING MAP FEATURES

<u>ROADS</u>			
ITEM	UNIT	EXAMPLE	
All roads paved/unpaved**	meters (0.1)	NC49 7.2	BST
Driveways	meters (0.1)	3.0	CONC
Sidewalk	meters (0.1)	1.200	CONC
Curb and/or Gutter	millimeters	750	CONC C&G
<u>MAJOR STRUCTURES</u>			
Box Culvert	meters (0.1)	2.4 X 1.8	CONC
Wing/Head/End Walls	meters (0.1)	2.4	CONC WW'S
<u>MINOR STRUCTURES</u>			
All Pipe Culverts	millimeters	600	CONC
Head/End Walls	meters (0.1)	1.8	CONC HW
Storm Sewer Line	millimeters	600	CONC
Paved Ditch	millimeters	1200	CONC
<u>BUILDINGS and OTHER CULTURE</u>			
Fence	millimeters	1050	WD
Wall	millimeters	1950	ROCK
Underground Tank	liters	18,000	1 GAS
<u>UTILITIES</u>			
All Pipes	millimeters	50	WATER

Road Design Data / Ohio



George V. Volnovich
Governor

OHIO DEPARTMENT OF TRANSPORTATION

25 South Front Street
P.O. Box 898
Columbus, Ohio 43216-0898

Metric Supplement - Mar. 31, 1993

DESIGN CRITERIA - NEW & RECONSTRUCTED BRIDGES	302-1
	REFERENCE SECTION 302.1

FUNCTIONAL CLASS.	TRAFFIC		LATERAL CLEARANCES (meters) (ON ADDITION TO APPROACH PAVEMENT)						MINIMUM DESIGN LOADING	VERTICAL CLEARANCE OVER SURFACED ROADWAY (J)				
	CURRENT ADT	DHV	ON BRIDGE (A)				UNDER BRIDGE (P)			MINIMUM	PREFERRED			
			RURAL		URBAN		MINIMUM	PREFERRED						
			URBAN	PREFERRED	MINIMUM	PREFERRED								
URBAN INTERSTATE	ALL	ALL	3.0 R(B) L2 L(N) (O)	3.6 R L8 L(M) (O)	↑↑↑↑↑ ↑↑↑↑↑ ↑↑↑↑↑ ↑↑↑↑↑ ↑↑↑↑↑ ↑↑↑↑↑ ↑↑↑↑↑	↑↑↑↑↑ ↑↑↑↑↑ ↑↑↑↑↑ ↑↑↑↑↑ ↑↑↑↑↑ ↑↑↑↑↑ ↑↑↑↑↑	↑↑↑↑↑ ↑↑↑↑↑ ↑↑↑↑↑ ↑↑↑↑↑ ↑↑↑↑↑ ↑↑↑↑↑ ↑↑↑↑↑	HS-20	5.0m (K)	5.2m				
RURAL INTERSTATE	ALL	ALL	3.0 R(B) L2 L(N) (O)	3.6 R L8 L(M) (O)					(F)	↑↑↑↑↑ ↑↑↑↑↑ ↑↑↑↑↑	HS-20	5.0m (K)	5.2m	
FREEWAYS & EXPRESSWAY	ALL	ALL	3.0 R(B) L2 L(N) (O)	3.6 R L8 L(M) (O)								↑↑↑↑↑ ↑↑↑↑↑ ↑↑↑↑↑	HS-20	5.0m (K)
ARTERIALS	—	> 400	3.0 (B)	3.6				↑↑↑↑↑ ↑↑↑↑↑ ↑↑↑↑↑ ↑↑↑↑↑						↑↑↑↑↑ ↑↑↑↑↑ ↑↑↑↑↑ ↑↑↑↑↑
	—	201-400	2.4 (B)	3.0										
	≥ 2400	≤ 200	L8 (B)	2.4										
	< 400	—	L2 (B)	L8										
COLLECTORS	—	> 400	2.4 (B)	3.0	↑↑↑↑↑ ↑↑↑↑↑ ↑↑↑↑↑ ↑↑↑↑↑	↑↑↑↑↑ ↑↑↑↑↑ ↑↑↑↑↑ ↑↑↑↑↑	HS-20	4.4m	4.6m					
	—	201-400	L2 (B)	2.4										
	—	100-200	L2 (END)	L8										
	≥ 2400	< 100	L2 (END)	L2										
LOCALS	—	> 400	2.4 (B)	3.0	↑↑↑↑↑ ↑↑↑↑↑ ↑↑↑↑↑ ↑↑↑↑↑	↑↑↑↑↑ ↑↑↑↑↑ ↑↑↑↑↑ ↑↑↑↑↑	HS-20	4.4m	4.6m					
	—	201-400	0.9	2.4										
	—	100-200	0.9	L8										
	> 400	< 100	0.9	L2										
		≤ 400	—	0.6	L2									

For structure criteria not contained in this table, refer to Bridge Design Manual from Bureau of Bridges and Structural Design.

- Should be reduced to 2.4m if footnote (B) on Figure 301-3 applies.
- ‡ Should be reduced to L8m if footnote (M) on Figure 301-3 applies.

For additional notes, see adjacent sheet.

Road Design Data / Virginia



COMMONWEALTH of VIRGINIA

DEPARTMENT OF TRANSPORTATION
1401 EAST BROAD STREET
RICHMOND, 23219

PLAN ELEMENT INFORMATION PRESENTLY RECOMMENDED BY VDOT

- 1 - Sheet size will remain the same.
- 2 - Stationing - 100 meter method
- 3 - Scales:

Plan Sheets

- a) Rural - 1:500 (Plan sheet covers 400 m± along centerline)
- b) Urban - 1:250 (Plan sheet covers 200 m± along centerline)

Profile Sheets

- a) Rural - 1:500 Horizontal; 1:100 Vertical
- b) Urban - 1:250 Horizontal; 1:50 Vertical

Cross-sections

- a) Rural - 1:100
- b) Urban - 1:50

- 4 - Pavement cross-slope - 2%
Shoulder cross-slope - 5% Paved; 6% Unpaved; 8% unpaved Local
- 5 - Degree of curve will no longer be used. All horizontal curve data will be based on the radius in meters.
- 6 - Degree-Minute-Second will be retained for angular measurement.
- 7 - Computed spiral transitions will be used for Rural curves with radius less than or equal to 850 meters.
- 8 - Cross-section interval - 20 meters (Rural)
10 meters (Urban)
- 9 - All survey information will be expressed in meters except property data. Only property which is surveyed will be expressed in meters - other property data will be shown in units recorded in court records.

Road Design Data / Virginia (continued)

14

Metric

Rev. 5-1-93

- 10 - Until computer software and other hydraulic design aids are available in metric, hydraulic design will continue to be performed in English units with descriptions of proposed structures converted to metric after computations are complete.
- 11 - Dual units will not be shown on plans with the probable exception of the R/W Data Sheet.
- 12 - Chords rather than concentric curves will be used to describe proposed R/W where a spiral curve transition is used.
- 13 - When converting meters to feet and extreme accuracy is needed, use the conversion factor for U.S. Survey Feet rather than the slightly different factor for the International Foot. The factors are as follows:

U.S. Survey Feet

For conversion of meters to U.S. Survey Feet, multiply the meters by 39.37 + 12.0 which is 3.28083333333 to 12 significant figures.

International Feet

For conversion of meters to International Feet, multiply the meters by 100.0 + 30.48 which is 3.28083989501 to 12 significant figures.

Note: This information is preliminary and subject to change as further information is received.

Road Design Data / Virginia (continued)

Sample Typical Section Sheet

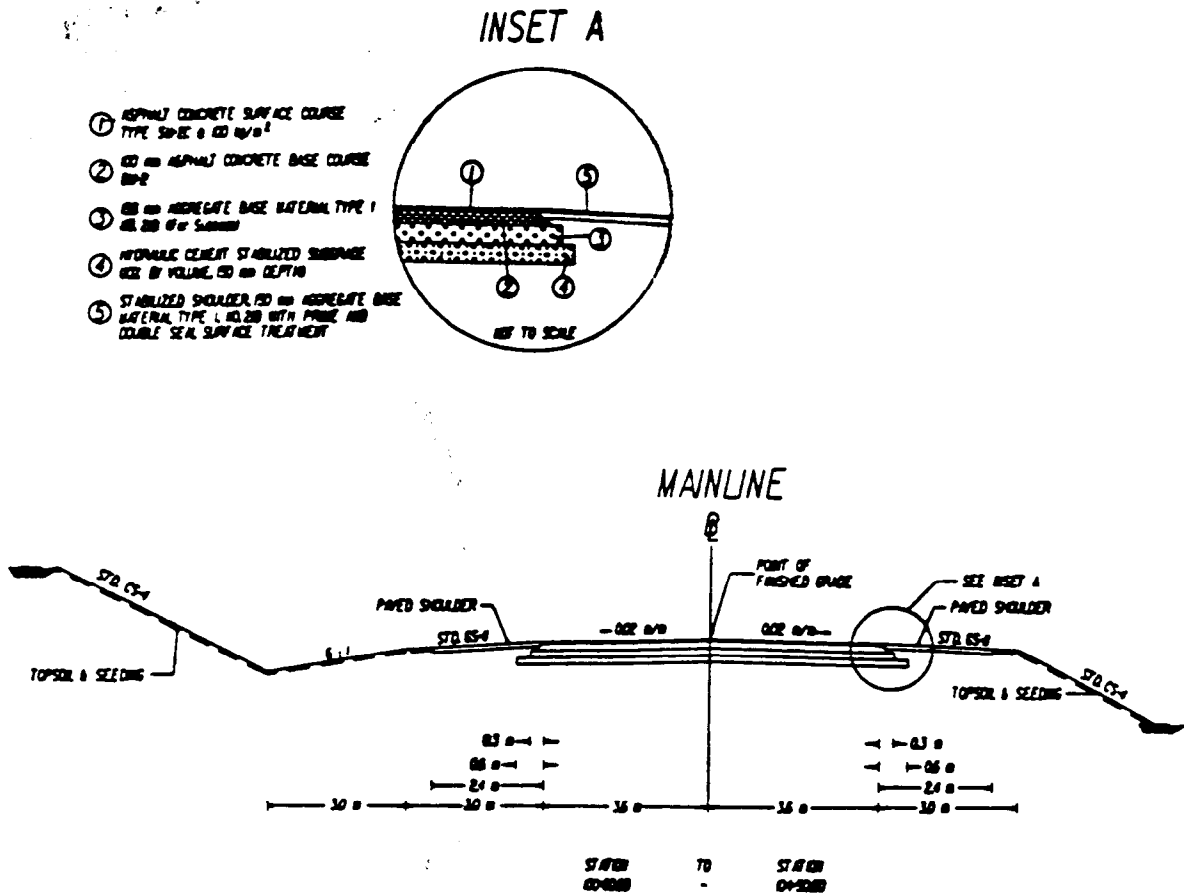

When liquid asphalt material is used as a curing material for a hydraulic cement or lime stabilized course, it shall be CWS-2, CWS-2h or CWS-2 and applied at the rate of 0.75 L/m². Where necessary for maintenance of construction traffic or public traffic, cover material Fine Aggregate Uniform Grading #3 shall be applied at the rate of 0.8 kg/m². All costs for such curing materials and any cover materials shall be included in price bid for the hydraulic cement or lime stabilized course.

The surface course shall be placed in two applications, as directed by the Engineer. This will facilitate in the maintaining of two way traffic on the new lane and associated pavement striping.

In case of temporary connections, tie-ins, and short sections of heavy traffic, Stabilized Subgrade is to be replaced by 150 mm of aggregate base material Type 1, No. 200. The substitution should only be used where absolutely necessary.

Prime shoulders with Liquid Asphalt Material RC-70 @ 0.95 L/m² and cover with Aggr. No. 78 @ 11kg/m². Double seal with Liquid Asphalt Material RC-250 @ 0.75 L/m² and cover with Aggregate No. 78 (Crushed stone) @ 11kg/m².

The existing roadway that is to be utilized should be overlaid with 75 kg/m² of asphalt concrete Type SP-EC and the shoulders should be built up with aggregate base material Type 1, No. 200. The width and depth would be variable depending upon the existing circumstances.

Acknowledgments

Black and Veatch MO
Brecher Associates PA
BRR Associates PA
CRSS Architects
Daroff Design PA
Dubois and King VT
DWL Architects AZ
Geddes Brecher Qualls Cunningham PA
Gehman + Associates VA
Gilbane Building Company
Hayes Seay Mattern Mattern VA
Heery Program Management
Holmes and Narver CA
Martin Marietta Energy Systems TN
Pahl Pahl Pahl CO
Simpson Gumpertz Heger MA
Skidmore Owings Merrill DC
Square D
Sverdrup Technology MD
The Kling Lindquist Partnership PA
3D/International

Our many helpful friends in corporations, and provincial and federal agencies in Canada.

The many US federal, state, and local agencies that provided input and assistance.

Others who have assisted us, and who we have negligently, but unintentionally, failed to mention.

Standard Graphic Design Data:

1. Titles for drawings shall be 25 mm from top edge.
2. Left and right margins shall be 30 mm.
3. Text should preferably start 40 mm from top edge.
4. Bottom margin should be minimum 20 mm.