

UNIFIED FACILITIES CRITERIA (UFC)

STRUCTURAL ENGINEERING



APPROVED FOR PUBLIC RELEASE; DISTRIBUTION UNLIMITED

UNIFIED FACILITIES CRITERIA (UFC)

STRUCTURAL ENGINEERING

Any copyrighted material included in this UFC is identified at its point of use. Use of the copyrighted material apart from this UFC must have the permission of the copyright holder.

U.S. ARMY CORPS OF ENGINEERS

NAVAL FACILITIES ENGINEERING COMMAND (Preparing Activity)

AIR FORCE CIVIL ENGINEER CENTER

Record of Changes (changes are indicated by \1\ ... /1/)

Change No.	Date	Location
<u>1</u>	<u>15 May 2014</u>	<u>Updated wind data and other minor modifications.</u>
<u>2</u>	<u>20 June 2016</u>	<u>Adopts 2015 IBC</u>
<u>3</u>	<u>12 Sept 2016</u>	<u>Further updated to reflect 2015 IBC</u>

This UFC supersedes UFC 3-301-01, dated 27 January 2010 with change 3 of 31 January 2012.

FOREWORD

The Unified Facilities Criteria (UFC) system is prescribed by MIL-STD 3007 and provides planning, design, construction, sustainment, restoration, and modernization criteria, and applies to the Military Departments, the Defense Agencies, and the DoD Field Activities in accordance with [USD \(AT&L\) Memorandum](#) dated 29 May 2002. UFC will be used for all DoD projects and work for other customers where appropriate. All construction outside of the United States is also governed by Status of Forces Agreements (SOFA), Host Nation Funded Construction Agreements (HNFA), and in some instances, Bilateral Infrastructure Agreements (BIA.) Therefore, the acquisition team must ensure compliance with the most stringent of the UFC, the SOFA, the HNFA, and the BIA, as applicable.

UFC are living documents and will be periodically reviewed, updated, and made available to users as part of the Services' responsibility for providing technical criteria for military construction. Headquarters, U.S. Army Corps of Engineers (HQUSACE), Naval Facilities Engineering Command (NAVFAC), and Air Force Civil Engineer Center (AFCEC) are responsible for administration of the UFC system. Defense agencies should contact the preparing service for document interpretation and improvements. Technical content of UFC is the responsibility of the cognizant DoD working group. Recommended changes with supporting rationale should be sent to the respective service proponent office by the following electronic form: [Criteria Change Request](#). The form is also accessible from the Internet sites listed below.

UFC are effective upon issuance and are distributed only in electronic media from the following source:

- Whole Building Design Guide web site <http://dod.wbdg.org/>.

Refer to UFC 1-200-01, *DoD Building Code (General Building Requirements)*, for implementation of new issuances on projects.

AUTHORIZED BY:



JAMES C. DALTON, P.E.
Chief, Engineering and Construction
U.S. Army Corps of Engineers



JOSEPH E. GOTT, P.E.
Chief Engineer
Naval Facilities Engineering Command



SCOTT HARTFORD, Colonel, USAF, P.E.
Director
Facilities Engineering Center of Excellence
AF Civil Engineer Center

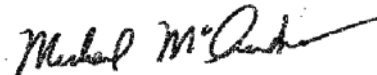

MICHAEL McANDREW
Director, Facilities Investment and Management
Office of the Deputy Under Secretary of Defense
(Installations and Environment)

**UNIFIED FACILITIES CRITERIA (UFC)
REVISION SUMMARY SHEET**

Subject: UFC 3-301-01, *Structural Engineering*

Cancel: UFC 3-301-01, *Structural Engineering* dated 27 January 2010 with change 3 of 31 January 2012

Description of Changes:

- This UFC adopts the structural design provisions of the 2012 *International Building Code* (2012 IBC) for use in DoD building design and renovation.
- Live load table is updated to coordinate with 2015 IBC.
- Site-specific structural load data tables for wind are updated to the ultimate design wind speed values from 2012 IBC which are the basic wind speed values from ASCE/SEI 7-10.
- Site-specific structural load data tables for seismic ground motion parameters are updated to the risk-adjusted maximum considered earthquake values and include the peak ground accelerations from ASCE/SEI 7-10.

\1\

- Revised Table E-1 Wind Speeds for Elmendorf AFB & Fort Richardson, Alaska.
- Added OCONUS seismic risk conversion equations in Table F-3 footnote.
- Eliminated call for specific type of joint in Section B.2 & E-3 ("control").

/1/

\2\

- Adopts 2015 IBC. (All references to 2012 IBC have been updated to 2015 IBC)
- Defines DOD specific special Inspection requirements.
- Updated seismic design value for the Kwajalein based on ERDC Report, *Probabilistic Seismic Hazard Analysis for Kwajalein Atoll, Republic of the Marshall Islands*, dated August 2015

Reasons for Changes:

- The updated UFC is designed to be consistent with and to supplement the guidance contained in 2015 IBC as modified by UFC 1-200-01.

Impact: There are negligible cost impacts. However, the following benefit should be realized:

- Load tables ensure that the locations identified and the loadings described are complete and current with the most up-to-date available information.

- DoD structural design criteria are current with industry codes and standards.

Non-Unified Items: This document contains no non-unified items

/2/

\3\

Description of Changes:

A footnote has been added to table E-3, which allows for a 20% reduction in seismic acceleration values for Guam, based on a site specific ground motion study conducted by URS Corporation, dated April 1, 2016, and per ASCE 7-10 21.4.

Reason for Changes:

A site specific seismicity study for Guam was funded by the Air Force to determine whether the code prescribed seismic design force could be reduced. The study's findings, in combination with code prescribed procedures for site specific ground motion studies, allowed for a 20% reduction in seismic design force.

/3/

CANCELLED

TABLE OF CONTENTS

CHAPTER 1 INTRODUCTION	1
1-1 PURPOSE AND SCOPE	1
1-2 BACKGROUND	1
1-3 APPLICABILITY	1
1-4 OTHER CRITERIA	1
1-4.1 General Building Requirements	2
1-4.2 Seismic Design	2
1-4.3 Progressive Collapse	2
1-5 REFERENCES	2
CHAPTER 2 MODIFICATIONS TO IBC	3
2-1 CHAPTER 16 - STRUCTURAL DESIGN	3
2-1.1 Section 1603 - CONSTRUCTION DOCUMENTS	3
2-1.2 Section 1604 - GENERAL DESIGN REQUIREMENTS	4
2-1.3 Section 1607 - LIVE LOADS	9
2-1.4 Section 1608 - SNOW LOADS	10
2-1.5 Section 1609 - WIND LOADS	11
2-1.6 Section 1613 - EARTHQUAKE LOADS	13
2-1.7 Section 1615 – STRUCTURAL INTEGRITY [Deletion]	13
2-2 CHAPTER 17 - SPECIAL INSPECTIONS AND TESTS	14
2-2.1 Section 1701 - GENERAL	14
2-2.2 Section 1703 - APPROVALS	14
2-2.3 Section 1704 – SPECIAL INSPECTIONS AND TESTS, CONTRACTOR RESPONSIBILITY AND STRUCTURAL OBSERVATIONS	15
2-2.4 Section 1705 – REQUIRED SPECIAL INSPECTIONS AND TESTS ..	16
2-3 CHAPTER 18 - SOILS AND FOUNDATIONS	17
2-3.1 Section 1808 – FOUNDATIONS	18
2-3.2 Section 1809 - SHALLOW FOUNDATIONS	18
2-4 CHAPTER 19 - CONCRETE	20
2-4.1 Section 1901 – GENERAL	20
2-4.2 Section 1904 - DURABILITY REQUIREMENTS	20
2-4.3 Section 1906 – STRUCTURAL PLAIN CONCRETE	20

2-4.4	Section 1907 - MINIMUM SLAB PROVISIONS	20
2-5	CHAPTER 21 - MASONRY	26
2-5.1	Section 2101 - GENERAL.....	26
2-5.2	Section 2104 - CONSTRUCTION.....	26
2-5.3	Section 2109 - EMPIRICAL DESIGN OF MASONRY [Deletion].....	27
2-6	CHAPTER 22 - STEEL.....	27
2-6.1	Section 2204 - CONNECTIONS	27
2-6.2	Section 2205 - STRUCTURAL STEEL	27
2-6.3	Section 2210 - COLD-FORMED STEEL.....	27
2-6.4	Section 2211 - COLD-FORMED STEEL LIGHT-FRAMED CONSTRUCTION.....	28
CHAPTER 3	MODIFICATIONS TO ASCE/SEI 7.....	29
3-1	CHAPTER 1 – GENERAL	29
3-1.1	1.3.1 – Strength and Stiffness [Supplement].....	29
3-1.2	1.3.1.3 – Performance Based Procedures [Replacement].....	29
3-1.3	1.3.1.3.3 – Documentation [Replacement].....	29
3-2	CHAPTER 2 – COMBINATIONS OF LOADS	29
3-2.1	2.3.5 – Load Combinations Including Self-Straining Loads [Supplement]	29
3-2.2	2.4.4 – Load Combinations Including Self-Straining Loads [Supplement]	29
3-2.3	2.5.1 – Applicability [Replacement].....	30
3-2.4	2.5.2 – Load Combinations [Deletion].....	30
3-2.5	2.5.3 – Stability Requirements [Deletion].....	30
3-3	CHAPTER 7 – SNOW LOADS.....	30
3-3.1	7.4 – Sloped Roof Snow Loads, p_s [Supplement]	30
3-4	CHAPTER 11 – SEISMIC DESIGN CRITERIA	30
3-4.1	11.1.3 – Applicability [Supplement].....	30
3-4.2	11.2 – Definitions [Replacement].....	30
3-5	CHAPTER 15 – SEISMIC DESIGN REQUIREMENTS FOR NONBUILDING STRUCTURES.....	31
3-5.1	15.4.5 – Drift Limitations [Replacement]	31
CHAPTER 4	OTHER STRUCTURES	33

4-1	HIGHWAY BRIDGE DESIGN.....	33
4-2	RAILROAD BRIDGE DESIGN	33
4-3	TANKS FOR LIQUID STORAGE	33
4-4	TANKS FOR PETROLEUM STORAGE.....	33
4-5	ENVIRONMENTAL ENGINEERING CONCRETE STRUCTURES	33
4-6	PRESTRESSED CONCRETE TANKS.....	33
4-7	WATER TREATMENT FACILITIES	33
4-8	TRANSMISSION TOWERS AND POLES.....	33
4-9	ANTENNA TOWERS.....	33
4-10	PEDESTRIAN BRIDGES	33
	APPENDIX A REFERENCES.....	35
	APPENDIX B BEST PRACTICES	41
B-1	STRUCTURAL DESIGN.....	41
B-1.1	Building Drift Limits	41
B-1.2	Impact Resistant Glazing.....	41
B-1.3	Hard Wall Buildings	42
B-1.4	Wind and Seismic Loads on Photovoltaic Arrays.....	42
B-1.5	Wind Loads on Buildings with Large Openings.....	42
B-2	SOILS AND FOUNDATIONS.....	43
B-2.1	Gable Bent Footings	43
B-2.2	Footings on Expansive Soils.....	43
B-2.3	Footings Depth Due to Frost.....	43
B-3	CONCRETE.....	44
B-3.1	Slab-on-Ground Concrete Strength	44
B-3.2	Slab-on-Ground Joints.....	44
B-3.3	Slab-on-Ground Drying Shrinkage.....	46
B-3.4	Slab-on-Ground Vapor Retarder/Barrier	46
B-3.5	Post-Installed Adhesive Concrete Anchors.....	46
B-4	MASONRY.....	46
B-4.1	Masonry Veneer Base Detail	46
B-5	STEEL	46
B-5.1	Shelf Angles for Masonry.....	46

B-5.2	Cold-Formed Continuous Beams and Joists.....	47
B-5.3	Masonry Veneer/Steel Stud Wall Detailing	47
B-5.4	Steel Structures in Corrosive Environments	47
B-5.5	Steel Structures in Arctic and Antarctic Zones.....	48
B-5.6	Steel Column Base Plate Shear Transfer	48
B-5.7	Steel Joist Connections	49
B-6	Wood	49
B-6.1	Connections.....	49
APPENDIX C ABBREVIATIONS		51
APPENDIX D MINIMUM UNIFORMLY DISTRIBUTED LIVE LOADS, L_o , AND MINIMUM CONCENTRATED LIVE LOADS.....		55
D-1	REFERENCES.	55
APPENDIX E SITE-SPECIFIC STRUCTURAL LOADING DATA – UNITED STATES, ITS TERRITORIES AND POSSESSIONS.....		63
E-1	Wind Loading Data Table.	63
E-2	Snow Loading and Frost Penetration Data Table.	63
E-3	Earthquake Loading Data Table.	63
APPENDIX F SITE-SPECIFIC STRUCTURAL LOADING DATA – OUTSIDE OF THE UNITED STATES, ITS TERRITORIES AND POSSESSIONS.....		111
F-1	Wind Loading Data Table.	111
F-2	Snow Loading and Frost Penetration Data Table.	111
F-3	Earthquake Loading Data Table.	111
APPENDIX G SEISMIC SPECTRAL ACCELERATION MAPS AT SELECTED LOCATIONS OUTSIDE OF THE UNITED STATES, ITS TERRITORIES AND POSSESSIONS		161

TABLES

TABLE 2-1 LATERAL DEFLECTION LIMITS FOR FRAMING SUPPORTING EXTERIOR WALL FINISHES ^{A,B,C}	5
TABLE 2-2 - RISK CATEGORY OF BUILDINGS AND OTHER STRUCTURES.....	6
TABLE 2-3 – REQUIRED SPECIAL INSPECTIONS AND TESTS OF MECHANICAL AND ELECTRICAL COMPONENTS*	19
TABLE 2-4 - MAXIMUM ALLOWABLE WALL LOAD AT A THICKENED SLAB FOR WALL LOAD NEAR CENTER OF SLAB OR NEAR KEYED OR DOWELED JOINTS	22

TABLE 2-5 - MAXIMUM ALLOWABLE WALL LOAD AT A THICKENED SLAB FOR WALL LOAD NEAR FREE EDGE.....	23
TABLE D-1 MINIMUM UNIFORMLY DISTRIBUTED LIVE LOADS AND MINIMUM CONCENTRATED LIVE LOADS ^G	55
TABLE E-1 - WIND LOADING DATA – UNITED STATES, ITS TERRITORIES AND POSSESSIONS	63
TABLE E-2 - SNOW LOADING AND FROST PENETRATION DATA – UNITED STATES, ITS TERRITORIES AND POSSESSIONS.....	79
TABLE E-3 - EARTHQUAKE LOADING DATA – UNITED STATES, ITS TERRITORIES AND POSSESSIONS.....	92
TABLE F-1 - WIND LOADING DATA – OUTSIDE OF THE UNITED STATES, ITS TERRITORIES AND POSSESSIONS.....	112
TABLE F-2 – SNOW LOADING AND FROST PENETRATION DATA – OUTSIDE OF THE UNITED STATES, ITS TERRITORIES AND POSSESSIONS.....	125
TABLE F-3 - EARTHQUAKE LOADING DATA – OUTSIDE OF THE UNITED STATES, ITS TERRITORIES AND POSSESSIONS.....	134

FIGURES

FIGURE 2-1 - WIDTHS OF THICKENED SLABS AND SLAB EDGE CONDITIONS UNDER WALL LOADS.....	25
FIGURE B-1 – DESIGN DEPTH OF BOTTOM OF BUILDING FOUNDATION.....	45
FIGURE G-1 - AFGHANISTAN – RISK-TARGETED MAXIMUM CONSIDERED EARTHQUAKE HORIZONTAL GROUND MOTION OF 0.2-SECOND SPECTRAL RESPONSE ACCELERATION (5 PERCENT OF CRITICAL DAMPING), SITE CLASS B.....	161
FIGURE G-2 - AFGHANISTAN – RISK-TARGETED MAXIMUM CONSIDERED EARTHQUAKE HORIZONTAL GROUND MOTION OF 1-SECOND SPECTRAL RESPONSE ACCELERATION (5 PERCENT OF CRITICAL DAMPING), SITE CLASS B.....	162

This page intentionally left blank.

CANCELLED

CHAPTER 1 INTRODUCTION

1-1 PURPOSE AND SCOPE

This Unified Facility Criteria (UFC) provides requirements for structures designed and constructed for the Department of Defense (DoD). These technical requirements are based on the 2015 International Building Code (2015 IBC), as modified by UFC 1-200-01. This information shall be used by structural engineers to develop design calculations, specifications, plans, and design-build Requests for Proposal (RFPs).

1-2 BACKGROUND

UFC 1-200-01 uses and supplements 2015 IBC as the building code for DoD. Chapter 2 of this UFC further modifies the IBC for structural-specific design requirements and is organized by the chapter of IBC that each section modifies. Chapter 3 of this UFC further modifies ASCE/SEI 7-10 for structural-specific design requirements and is organized by the chapter of ASCE/SEI 7 that each section modifies. The climatic and seismic data included in this UFC are intended as tools to assist in the consistent interpretation of the corresponding data in the IBC at significant DoD installations within the United States, and as the basis for applying the provisions of UFC 1-200-01 to significant DoD installations outside of the United States. Chapter 4 provides additional guidance for the design of structures other than buildings. The 2015 IBC and ASCE/SEI 7-10 section modifications are one of four actions, according to the following legend:

[Addition] – Add new section, including new section number, not shown in 2015 IBC or ASCE/SEI 7-10.

[Deletion] – Delete referenced 2015 IBC or ASCE/SEI 7-10 section.

[Replacement] – Delete referenced 2015 IBC or ASCE/SEI 7-10 section or noted portion and replace it with the narrative shown.

[Supplement] – Add narrative shown as a supplement to the narrative shown in the referenced section of 2015 IBC or ASCE/SEI 7-10.

1-3 APPLICABILITY

This UFC applies to all service elements and contractors involved in the planning, design and construction of DoD facilities worldwide.

1-4 OTHER CRITERIA

Military criteria other than those listed in this document may be applicable to specific types of structure. Such structures shall meet the additional requirements of the applicable military criteria.

1-4.1 General Building Requirements

Comply with UFC 1-200-01, DoD Building Code (General Building Requirements). UFC 1-200-01 provides applicability of model building codes and government unique criteria for typical design disciplines and building systems, as well as for accessibility, antiterrorism, security, high performance and sustainability requirements, and safety. Use this UFC in addition to UFC 1-200-01 and the UFCs and government criteria referenced therein.

1-4.2 Seismic Design

For seismic design of buildings, refer to UFC 3-310-04.

1-4.3 Progressive Collapse

For design of buildings to resist progressive collapse, refer to UFC 4-023-03.

1-5 REFERENCES

For references see Appendix A.

CHAPTER 2 MODIFICATIONS TO IBC

2-1 CHAPTER 16 - STRUCTURAL DESIGN

2-1.1 Section 1603 - CONSTRUCTION DOCUMENTS

2-1.1.1 1603.2 - Delegated Engineered Systems [Addition]

The Structural Designer of Record (DOR) for a structure may delegate responsibility for the design of systems or component parts of the structure to a qualified delegated engineer. Both the engineer of record for the structure and the delegated engineer must comply with the requirements of this UFC. The following are some examples of delegated systems.

- a. Prefabricated wood components
- b. Cast-in-place post-tensioned concrete structural systems
- c. Precast, prestressed concrete components
- d. Open web steel joists and joist girders
- e. Pre-engineered metal buildings
- f. Specialty foundation systems
- g. Structural steel connections
- h. Cold-formed steel joist/stud/truss framing and pre-fabricated components
- i. Seismic design of nonstructural components
- j. Proprietary track for under-hung cranes and monorails
- k. Autoclaved aerated concrete
- l. $\sqrt{2}$ ATRP analysis (and/or testing) for building components /2/

The delegated engineer must sign and seal all work they design. The structural (DOR) must review all submittals that have been signed and sealed by the delegated engineer, to verify compliance with the design intent and the specified design criteria and to ensure coordination with the contract documents and other shop drawings. All submittals from the delegated engineer must be approved by the DOR prior to the start of fabrication of the system or component part and prior to any field construction that may be affected by the system or component part.

2-1.2 Section 1604 - GENERAL DESIGN REQUIREMENTS

2-1.2.1 1604.3 - Serviceability [Supplement]

The structural designer shall ensure that the maximum allowable frame drift is suitable for the proposed structure considering occupancy, use/function, and all details of construction. See ASCE/SEI 7 Appendix C “Serviceability Considerations” including commentary, and Section B-1.1 of UFC 3-301-01 for additional guidance.

In the wind design of a building or a non-building structure, the lateral drift shall not exceed $H/480$ based on a wind speed with a 10 year MRI. See Figure CC-1 of ASCE/SEI 7 for wind speeds with a 10 year MRI. Consideration shall be given to the cladding system when evaluating lateral drift as a more stringent drift limitation may be appropriate depending on the cladding system.

Exception: The drift limits can be modified with concurrence/approval from the AHJ.

Wall systems and other building elements that are not part of the lateral force-resisting system shall be detailed to ensure that they are not susceptible to damage. Masonry and other brittle wall systems are particularly susceptible to damage if not properly integrated into the design to ensure that they can adequately resist the stresses resulting from the building deformations or are effectively isolated to prevent damage.

Exception: Reinforced concrete frame members not designed as part of the seismic force-resisting system shall comply with Section 18.14 of ACI 318.

All structural vertical load-bearing wall elements shall be considered to be part of the lateral force-resisting system. All applicable provisions of UFC 3-310-04 Table 2-1 shall apply.

2-1.2.2 1604.3.1 - Deflections [Replacement]

Deflections of structural members shall not exceed the more restrictive of the limitations of Sections 1604.3.2 through 1604.3.5 or those permitted by Table 1604.3, or Table 2-1 of UFC 3-301-01.

2-1.2.3 1604.5 - Risk Category [Replacement]

Each building and structure shall be assigned a risk category in accordance with Table 2-2 of UFC 3-301-01. Where referenced standard specifies an occupancy category, the risk category shall not be taken as lower than the occupancy category specified therein. Importance factors for snow load, seismic load, and ice for each risk category are also shown in Table 2-2 of UFC 3-301-01.

Note: IBC section 1604.5.1 shall remain in effect as written.

TABLE 2-1 LATERAL DEFLECTION LIMITS FOR FRAMING SUPPORTING EXTERIOR WALL FINISHES^{a,b,c}

Brick veneer	L/600
Exterior Insulation Finish Systems	L/240
Cement board	L/360
Stone Masonry	VERIFY WITH STONE SUPPLIER
Plywood and Wood-Based Structural-Use Panels	L/240
Gypsum sheathing	L/240
Metal or vinyl siding and insulated metal panel	L/240

Notes to Table 2-1, “LATERAL DEFLECTION LIMITS FOR FRAMING SUPPORTING EXTERIOR WALL FINISHES”

- a. Lateral deflection limits under wind loads.
- b. The wind load is permitted to be taken as 0.42 times the “component and cladding” loads for the purpose of determining the deflection limits herein.
- c. L shall be calculated as $L = k \cdot l$, where k is the theoretical effective length factor, and l is the actual member length.

2-1.2.4 Table 1604.5 [Replacement]

Replace Table 1604.5 of the IBC with Table 2-2 of this UFC. (All references in the IBC to Table 1604.5 shall be interpreted as a reference to Table 2-2 of this UFC.)

TABLE 2-2 - RISK CATEGORY OF BUILDINGS AND OTHER STRUCTURES

Risk Category	Nature of Occupancy	Seismic Factor I_E	Snow Factor I_S	Ice Factor I_i
I	<p>Buildings and other structures that represent a low hazard to human life in the event of failure, including, but not limited to:</p> <ul style="list-style-type: none"> • Agricultural facilities • Certain temporary facilities • Minor storage facilities 	1.00	0.8	0.80
II	<p>Buildings and other structures except those listed in Risk Categories I, III, IV and V</p>	1.00	1.00	1.00
III	<p>Buildings and other structures that represent a substantial hazard to human life or represent significant economic loss in the event of failure, including, but not limited to:</p> <ul style="list-style-type: none"> • Buildings and other structures whose primary occupancy is public assembly with an occupant load greater than 300 people • Buildings and other structures containing <i>elementary school, secondary school, or daycare facilities</i> with an occupant load greater than 250 • Buildings and other structures containing <i>adult education facilities, such as colleges and universities</i>, with an occupant load greater than 500 • Group I-2 occupancies with an occupant load of 50 or more resident care recipients but not having surgery or emergency treatment facilities • Group I-3 occupancies • Any other occupancy with an occupant load greater than 5,000^a • Power-generating stations; water treatment facilities for potable water, waste water treatment facilities, and other public utility facilities that are not included in Risk Categories IV and V • Buildings and other structures not included in Risk Categories IV and V containing sufficient quantities of toxic, flammable, or explosive materials that: <ul style="list-style-type: none"> Exceed maximum allowable quantities per control area as given in Table 307.1(1) or 307.1(2) or per outdoor control area in accordance with <i>NFPA 1: Fire Code</i>; and are sufficient to pose a threat to the public if released.^b • <i>Facilities having high-value equipment, as designated by the AHJ</i> 	1.25	1.10	1.25

Risk Category	Nature of Occupancy	Seismic Factor I_E	Snow Factor I_S	Ice Factor I_i
IV	<p>Buildings and other structures designed as essential facilities, including, but not limited to:</p> <ul style="list-style-type: none"> • Group I-2 occupancies having surgery or emergency treatment facilities • Fire, rescue, and police stations, and emergency vehicle garages • Designated earthquake, hurricane, or other emergency shelters • Designated emergency preparedness, communication, and operation centers, and other facilities required for emergency response • Power-generating stations and other utility facilities required as emergency backup facilities for Risk Category IV structures. • Buildings and other structures containing quantities of highly toxic materials that: <ul style="list-style-type: none"> Exceed maximum allowable quantities per control area as given in Table 307.1(1) or 307.1(2) or per outdoor control area in accordance with NFPA 1, Fire Code; and are sufficient to pose a threat to the public if released.^b • Air traffic control tower (ATCT), Radar Approach Control Facility (RACF) and air traffic control centers unless the AHJ determines that the facility is classified as a non-essential facility and is not required for post-earthquake operations (i.e. minor facility, availability of an alternate temporary control facility, auxiliary outlying field, etc.). Contact the AHJ for additional guidance. • Emergency aircraft hangars that house aircraft required for post-earthquake emergency response; if no suitable back up facilities exist • Buildings and other structures not included in Risk Category V, having DoD mission-essential command, control, primary communications, data handling, and intelligence functions that are not duplicated at geographically separate locations, as designated by the using agency • Water storage facilities and pump stations required to maintain water pressure for fire suppression 	1.50	1.20	1.25

Risk Category	Nature of Occupancy	Seismic Factor I_E	Snow Factor I_S	Ice Factor I_i
V ^c	<p>Facilities designed as national strategic military assets, including, but not limited to:</p> <ul style="list-style-type: none"> • Key national defense assets (e.g. National Missile Defense facilities), as designated by the AHJ. • Facilities involved in operational missile control, launch, tracking, or other critical defense capabilities • Emergency backup power-generating facilities required for primary power for Category V occupancy • Power-generating stations and other utility facilities required for primary power for Category V occupancy, if emergency backup power generating facilities are not available <p>Facilities involved in storage, handling, or processing of nuclear, chemical, biological, or radiological materials, where structural failure could have widespread catastrophic consequences, as designated by the AHJ.</p>	1.0	1.50	1.50

Notes to Table 2-2, “RISK CATEGORY OF BUILDINGS AND OTHER STRUCTURES”

- a. For purposes of occupant load calculations, occupancies required by Table 1004.1.2 to use gross floor area calculations shall be permitted to use net floor area to determine the total occupant load.
- b. Where approved by the building official, the classification of buildings and other structures as Risk Category III or IV based on their quantities of toxic, highly toxic or explosive materials is permitted to be reduced to Risk Category II, provided it can be demonstrated by hazard assessment in accordance with Section 1.5.3 of ASCE/SEI 7 that a release of the toxic, highly toxic or explosive material is not sufficient to pose a threat to the public.
- c. A Risk Category has been added to address national strategic military assets. Structures in this risk category are designed to remain elastic during the MCE_R .

2-1.2.5 1604.11 - Fall Prevention and Protection [Addition]

When there is a hazard of falling from heights, fall prevention and protection measures shall be considered at a building or facility to protect personnel during occupancy and maintenance phases, or whenever there is a need or requirement to perform work at high locations, on equipment, near unprotected sides or edges, holes or openings, delivering material to or store equipment at heights as prescribed by the following standards:

- 29 CFR 1926, Subpart M,
- 29 CFR 1910, Subpart D
- Notices of Proposed Rulemaking, 29 CFR 1910
- ANSI/ASSE A1264.1
- ANSI/ASSE Z359

At the planning and design phase of a project, fall hazards shall be considered and eliminated whenever possible. Safe access to the work location at heights shall also be considered. When elimination or prevention of fall hazards is not feasible, the design shall include certified and labeled anchorages that are conveniently located to perform the work safely. The anchorages shall meet the requirements of the following standards:

- 29 CFR 1910, Subpart D /2/
- 29 CFR 1926.500, Subpart M,
- Notices of Proposed Rulemaking, 29 CFR 1910
- ANSI/ASSE Z359

Where fall protection is required in the vicinity of weight-handling equipment, care must be taken to prevent potential conflicts between the weight-handling equipment and the fall protection measures.

2-1.2.5.1 1604.11.1 – Loads, Load Combinations and Impact Factors [Addition]

For fall arrest loads that will impact the anchorages, in addition to load combinations and impact factors to be used in the design of personal fall protection systems, refer to ANSI/ASSE Z359.6.

2-1.2.5.2 1604.11.2 - Additional Fall Protection Considerations [Addition]

The design for anchorages attached to or embedded in concrete shall include consideration of both the static and the dynamic loads generated by the fall arrest system.

2-1.2.5.3 1604.12 - Expansion Joints [Addition]

Spacing of expansion joints shall follow the recommendations in *NAS Technical Report No. 65*.

2-1.3 Section 1607 - LIVE LOADS

2-1.3.1 1607.1 General [Replacement]

Live loads are those loads defined in Section 1602.1. Table D-1 of this UFC defines minimum uniformly distributed live loads and minimum concentrated live loads for the design of structures. Table D-1 is IBC Table 1607.1 with additional Occupancy or Use

classifications for military facilities. The classifications that have been added to IBC Table 1607.1 are shown in bold italics within Table D-1.

2-1.3.2 Table 1607.1 [Replacement]

Replace Table 1607.1 of the IBC with Table D-1 of this UFC. (All references in the IBC to Table 1607.1 shall be interpreted as references to Table D-1 of this UFC.)

2-1.3.3 1607.7.1 Loads [Replacement]

Where a structure does not restrict access for vehicles that exceed a 10,000 pound (4536 kg) gross vehicle weight rating, those portions of the structure subject to such loading shall be designed using the vehicular live loads, including consideration of impact and fatigue, in accordance with the AASHTO Bridge Design Specification.

2-1.3.4 1607.9. 5 Hangers [Addition]

For the purpose of design, the live load on hangers supporting floors and balconies shall be increased by 33 percent to account for impact.

2-1.3.5 1607.11 Distribution of Floor Loads [Supplement]

Add the following to the end of the paragraph: Partial floor live load distribution shall follow Section 4.3.3 of ASCE/SEI 7.

2-1.4 Section 1608 - SNOW LOADS

2-1.4.1 1608.4 - Specific Locations Within the United States [Addition]

Ground snow loads at DoD installations within the United States and its territories and possessions are identified in Table E-2 of UFC 3-301-01, to facilitate consistent interpretation of the information provided in Figure 1608.2 and Table 1608.2.

2-1.4.2 1608.5 - Specific Locations Outside of the United States [Addition]

Ground snow loads at specific locations outside of the United States and its territories and possessions are identified in Table F-2 of UFC 3-301-01. At locations where the ground snow load is not provided, use the best locally available information. For additional guidance contact the AHJ.

2-1.4.3 1608.6 - Snow Load Case Studies [Addition]

Snow load case studies may be done to clarify and refine snow loadings at site-specific locations with the approval of the AHJ. For Risk Category V facilities or where required by the AHJ, a site-specific study shall be conducted if the ground snow load is greater than 30 psf (1.4KPa). The methodology used to conduct snow load case studies at site-specific locations is presented in the Cold Regions Research and Engineering Laboratory (CRREL) report "Database and Methodology for Conducting Site Specific Snow Load Case Studies for the United States."

2-1.5 Section 1609 - WIND LOADS

2-1.5.1 1609.1.1 – Determination of Wind Loads [Supplement]

Add the following to the list of exceptions:

7. For winds parallel to the ridge of open buildings, the wind load delivered to the main wind force resisting system from the bare frames or partially clad end walls shall be determined in accordance with Section 1.3.4.5.4 of the Metal Building System Manual.

2-1.5.2 1609.1.3 – Aircraft Hangar Wind Loads [Addition]

Wind load on main wind force resisting system of aircraft hangars shall be determined based on the following conditions:

- Hangar doors closed for winds at the maximum design velocity. The structural forces shall be calculated based upon the assumption of a “partially enclosed building.” It is permissible to use the large volume reduction factor of ASCE/SEI 7 in determining the design wind pressures. It shall be assumed that a 1-inch (25-mm) strip around the perimeter of all hangar door panels is an opening and this shall be combined with the area of all unshielded fenestration.
- Hangar doors open to the maximum extent possible with a wind velocity of 60 mph (97 km/h). The structural forces shall be calculated upon the assumption of a “partially enclosed building.” Use the total open door area in the large volume reduction factor calculation.

2-1.5.3 1609.2 - Definitions [Replacement]

Replace the definition of Wind-Borne Debris Region in this section and IBC Section 202 with the following:

WIND-BORNE DEBRIS REGION. For locations within the United States and its territories and possessions, areas within hurricane-prone regions located:

1. Within 1 mile (1.61 km) of the coastal mean high water line where the ultimate design wind speed is 130 mph (58 m/s) or greater; or
2. In areas where the ultimate design wind speed is 140 mph (62.5 m/s) or greater; or Hawaii.

For locations outside of the United States and its territories and possessions, regions where the ultimate design wind speed is 140 mph (63.6 m/s) or greater.

For Risk Category II buildings and structures and Risk Category III buildings and structures, except health care facilities, the windborne debris region shall be based on Risk Category II wind speeds. For Risk Category IV buildings and structures and Risk

Category III health care facilities, the windborne debris region shall be based on Risk Category III-IV wind speeds. For Risk Category V buildings and structures the windborne debris region shall be based on Risk Category V wind speeds.

2-1.5.4 1609.3 – Ultimate Design Wind Speed [Supplement]

Add the following to the end of the section: For Risk Category V facilities the ultimate design wind speed, V_{ult} , should be determined in accordance with Section 26.5.3 of ASCE/SEI 7.

2-1.5.5 1609.3.1 - Wind Speed Conversion [Replacement]

When required, the ultimate design wind speed shall be converted to a nominal design wind speed, V_{asd} , using Equation 16-33a.

$$V_{asd} = \sqrt{0.6} V_{ult} \quad (\text{Equation 16-33a})$$

When required, the ultimate design wind speed shall be converted to a fastest-mile wind speed, V_{fm} , using Equation 16-33b.

$$V_{fm} = (\sqrt{0.6} V_{ult} - 10.5) / 1.05 \quad (\text{Equation 16-33b})$$

2-1.5.6 1609.3.2 - Specific Locations Within the United States [Addition]

Ultimate design wind speeds at DoD installations within the United States and its territories and possessions are identified in Table E-1 of UFC 3-301-01 to facilitate consistent interpretation of the information provided in Figures 1609.3(1), 1609.3(2), and 1609.3(3). To determine the wind speed at a specific location not included in Table E-1 use the web application on the Applied Technology Council website at <http://windspeed.atcouncil.org/>

2-1.5.7 1609.3.3 - Specific Locations Outside of the United States [Addition]

Ultimate design wind speeds at specific locations outside of the United States and its territories and possessions are identified in Table F-1 of UFC 3-301-01. At locations where the ultimate design wind speed is not provided, use the best locally available information. For additional guidance, contact the AHJ.

Use a minimum wind speed of 100 mph (161 km/h) for Risk Category I, 110 mph (177 km/h) for Risk Category II, 115 mph (185 km/h) for Risk Category III and IV or 140 mph (225 km/h) for Risk Category V at all locations unless a lower wind speed is approved by the AHJ.

2-1.6 Section 1613 - EARTHQUAKE LOADS

2-1.6.1 1613.3.1.1 - Specific Locations Within the United States [Addition]

Seismic parameters at DoD installations within the United States and its territories and possessions are identified in Table E-3 of UFC 3-301-01 to facilitate consistent interpretation of the information provided in Figures 1613.3.1(1) through 1613.3.1(8).

The values in Table E-3 were determined utilizing the United States Geological Survey (USGS) U.S. Seismic Design Maps Web Application, for ASCE 7-10 and utilizing latitude and longitude data. This tool or other approved software may be used to determine seismic design data where site-specific location information is available, with the approval of the AHJ.

The seismic acceleration parameters in Table E-3 were typically determined at the approximate geographical centroid of the installation / city. For larger installations and where the potential seismic accelerations vary considerably over relatively short distances, it may not be appropriate to use the acceleration values at the installation centroid. In Table E-3 the larger installations are identified and location specific seismic parameters for sites within the installation shall be determined using the USGS web application. For additional guidance contact the AHJ.

2-1.6.2 1613.3.1.2 - Specific Locations Outside of the United States [Addition]

Seismic ground motion parameters at specific locations outside of the United States and its territories and possessions are identified in Table F-3 of UFC 3-301-01. For locations not shown, the best available information shall be used with the approval of the AHJ. Appendix G includes available seismic spectral acceleration maps at selected locations outside of the United States. These maps may be used to interpolate the seismic ground motions at locations that are not identified in Table F-3.

2-1.6.3 1613.3.1.3 – Site Specific Seismicity Study Process [Addition]

The site specific ground motion procedures in Chapter 21 of ASCE/SEI 7 may be used to determine ground motions for any structure.

2-1.7 Section 1615 – STRUCTURAL INTEGRITY [Deletion]

This section shall be deleted in its entirety.

2-2 CHAPTER 17 - SPECIAL INSPECTIONS AND TESTS

2-2.1 Section 1701 - GENERAL

2-2.1.1 1701.1 - Scope [Supplement]

Add the following paragraph after the first paragraph:

Contractual relationships and the composition of the architect / engineer / construction (AEC) team differ from that contemplated by the language of 2015 IBC, when doing DoD construction. When performing design or construction using typical methods for in-house design, AE design, and contracting for construction, 2015 IBC/ASCE/SEI 7-10 terms of Authority Having Jurisdiction and Building Official shall be as defined in UFC 1-200-01.

∨\ Unless noted otherwise the following substitutions shall apply for implementing the IBC.

- “building official” - interpreted as “Authority Having Jurisdiction” as referenced in UFC 1– 200–01).
- “owner” - interpreted as “Authority Having Jurisdiction”
- “permit applicant” - interpreted as “contractor”

[C] 2-2.1.1 1701.1 - Scope [Supplement]

The context of the IBC terms “permit”, “permit application”, “permit applicant”, and “owner” must be modified for DoD projects. DoD functions as the building department/jurisdiction and the AHJ functions as the building official. When DoD advertises a project the building permit is effectively implied/granted. However the overall project may still require other permits related to site storm water, air quality, demolition disposal, etc.

/2/

2-2.2 Section 1703 - APPROVALS

2-2.2.1 1703.4 - Performance [Replacement]

New, unusual, or innovative materials, systems or methods previously untried may be incorporated into designs when evidence shows that such use is in the best interest of the Government from the standpoint of economy, lower life-cycle costs, and quality of construction. Supporting data, where necessary to assist in the approval of materials or assemblies not specifically provided for in the code, shall consist of valid evaluation

reports from International Code Council – Evaluation Services (ICC-ES), or other qualified testing and evaluation service with the prior approval of the AHJ.

2-2.2.2 1703.4.1 - Research and Investigation [Deletion]

This section shall be deleted in its entirety.

2-2.2.3 1703.4.2 - Research Reports [Deletion]

This section shall be deleted in its entirety.

2-2.3 Section 1704 – SPECIAL INSPECTIONS AND TESTS, CONTRACTOR RESPONSIBILITY AND STRUCTURAL OBSERVATIONS

/2\

2-2.3.1 1704.2 Special inspections and tests. [Replacement]

Replace the first paragraph with the following:

The contractor shall retain the services of one or more *approved agencies* to provide *special inspections* and tests during construction on the types of work specified in Section 1705 and identify the *approved agencies* to the *AHJ*. These *special inspections* and tests are in addition to the inspections by the *contractor* that are identified in Section 110.

2-2.3.2 1704.2.3 Statement of special inspections. [Replacement]

Replace the first paragraph with the following:

The DOR shall submit a statement of special inspections in accordance with Section 107.1. This statement shall be in accordance with Section 1704.3.

/2/

2-2.3.3 1704.6 – Structural Observations [Replacement]

Replace the first paragraph with the following:

/2\

Where required by the provisions of Section 1704.6.1 or 1704.6.2, structural observations shall be performed by the DOR or their designated representative. Structural observation does not include or waive the responsibility for the inspections in Section 110 or the special inspections in Section 1705 or other sections of this code.

/2/

**2-2.3.4 1704.6.1 – Structural Observations for Seismic Resistance
[Replacement]**

Replace item number one with the following:

1 - The structure is classified as Risk Category III, IV or V in accordance with Table 2-2.

Replace item number three with the following:

3 - The structure is assigned to Seismic Design Category E, is classified as Risk Category I or II in accordance with Table 2-2, and is greater than two stories above grade plane.

2-2.3.5 1704.7 – Special Inspector of Record [Addition]

When the provisions of Section 1704.6.1 or 1704.6.2 apply, the services of a Special Inspector of Record (SIOR) shall be retained by the Contractor as a third party quality assurance agent (see Section 2-17.1 of UFC 1-200-01). The SIOR shall be a licensed professional engineer in a state acceptable to the AHJ. The SIOR shall submit qualifications acceptable to the AHJ.

**2-2.3.6 1704.7.1 – Duties of the Special Inspector of Record (SIOR)
[Addition]**

The duties of the SIOR are defined in the following UFGS specifications;

- | | |
|---------------------------|-----------------------------|
| Design-Bid-Build projects | - specification 01 45 35 |
| Design-Build projects | - specification 01 45 35.05 |

/2/

2-2.3.7 1704.7.2 – Final Inspection Report [Addition]

When the work requiring Special Inspections is completed and all nonconforming items have been resolved to the satisfaction of the Registered Design Professional in Responsible Charge, the Contractor shall notify the SIOR to submit a Final Special Inspection Report to the AHJ, the Registered Design Professional in Responsible Charge, and the Contractor. The Final Special Inspection Report shall attest that Special Inspection has been performed on all work requiring Special Inspection and that all nonconforming work and corrections of all discrepancies noted in the daily reports was resolved to the satisfaction of the Registered Design Professional in Responsible Charge. The Final Special Inspection Report shall be signed, dated, and shall bear the seal of the SIOR.

2-2.4 Section 1705 – REQUIRED SPECIAL INSPECTIONS AND TESTS

2-2.4.1 1705.3.3 – Adhesive Anchors [Addition]

The engineer of record shall determine the proof load (see ACI 318 Section 17.8.2.1) to be used for field testing and shall indicate in the construction documents which anchors are considered critical for testing.

2-2.4.2 1705.12 – Special Inspections for Seismic Resistance [Supplement]

Add the following before the paragraph: Special Inspections itemized in Sections 1705.12.1 through 1705.12.9 shall apply to structures assigned to Risk Category V.

2-2.4.3 1705.12.6 – Plumbing, Mechanical and Electrical Components [Supplement]

Add the following after the paragraph:

Special inspection and verification are required for Designated Seismic Systems and shall be performed as required by this section and Table 2-3.

The Registered Design Professional in Responsible Charge shall prepare a Statement of Special Inspections in accordance with Section 1704 for the Designated Seismic Systems. The Statement of Special Inspections shall define the periodic walk-down inspections that shall be performed to ensure that the non-structural elements satisfy life safety mounting requirements. The walk-down inspections shall be performed by design professionals who are familiar with the construction and installation of mechanical, and electrical components, and their vulnerabilities to earthquakes. The selection of the design professional shall be subject to the approval of the AHJ.

Designated Seismic Systems shall require a final walk-down inspection by the Registered Design Professional in Responsible Charge and by the Nonstructural Component Design Review Panel for Risk Category V installations (see Section 4-1601.2.2 of UFC 3-310-04). The final review shall be documented in a report. The final report prepared by the Registered Design Professional in Responsible Charge shall include the following:

1. Record/observations of final site visit
2. Documentation that all required inspections were performed in accordance with the Statement of Special Inspections.
3. Documentation that the Designated Seismic Systems were installed in accordance with the construction documents and the requirements of Chapter 17, as modified by this section.

2-2.4.4 1705.13 – Testing for Seismic Resistance [Supplement]

Add the following before the first paragraph: Any requirements for structural testing for structures assigned to Seismic Design Category C or higher shall also apply to structures assigned to Risk Category V.

2-3 CHAPTER 18 - SOILS AND FOUNDATIONS

2-3.1 Section 1808 – FOUNDATIONS

2-3.1.1 1808.4 - Vibratory Loads [Supplement]

Add the following to the end of the paragraph: Design foundations in accordance with ACI 351.3R or ACI 350.4R, as applicable, and UFC 3-220-01.

2-3.1.2 1808.8.2.1 - Reinforcement [Addition]

For footings over three feet (914 mm) thick, the minimum ratio of reinforcement area to gross concrete area in each direction shall be 0.0015, with not less than one-half nor more than two-thirds of the total reinforcement required placed near any one face. Minimum bar size shall be No. 4 (#13M) with a maximum spacing of 12 inches (305 mm). [See 15.10.4 of 318-11]

2-3.2 Section 1809 - SHALLOW FOUNDATIONS

2-3.2.1 1809.5.1 - Frost Line Depth [Addition]

Depths to the frost line at specific locations within the United States and its territories and possessions are identified in Table E-2 of UFC 3-301-01. Frost line depths at specific locations outside of the United States are identified in Table F-2 of UFC 3-301-01. At locations where frost depths are not provided, use the best locally available information. For additional guidance contact the AHJ. For guidance on the depth of footings due to frost see Section B-2.3 of UFC 3-301-01.

TABLE 2-3 – REQUIRED SPECIAL INSPECTIONS AND TESTS OF MECHANICAL AND ELECTRICAL COMPONENTS*

TYPE	CONTINUOUS SPECIAL INSPECTION	PERIODIC SPECIAL INSPECTION	Standard Reference	IBC Reference
1. Equipment Verification				
a. Verify model number and serial number are in conformance with project specific seismic qualification (PSSQ).		x		
b. Verify Tag ID is correct and installed per specifications.		x		
2. Equipment Mounting				
a. Verify that Anchor Base Bolting is installed per PSSQ		x		
b. Verify that Equipment Bracing is Installed per PSSQ		x		
c. Verify that Bracing Attachments are installed per PSSQ		x		
3. Utility Conduit/Piping				
a. Verify that Conduit/Piping is connected to the equipment per PSSQ (flex or rigid)		x		
b. Verify that Conduit/Piping is seismically supported independently of equipment and in accordance with PSSQ support requirements.		x		
4. Clearance				
a. Adjacent Equipment – Verify that there is adequate gap to eliminate possibility of pounding.		x		
b. Conduit/Piping - Verify that there is adequate gap to eliminate possibility of pounding.		x		

*All required inspections and verifications shall be carried out for each piece of equipment constituting part of the Designated Seismic Systems.

2-4 CHAPTER 19 - CONCRETE

2-4.1 Section 1901 – GENERAL

2-4.1.1 1901.7 - Construction Joints [Addition]

Provide construction, contraction, and expansion joints in structures in accordance with ACI 224.3R and ACI 318, Section 26.5.6.

2-4.1.2 1901.8 – Tension Ties [Addition]

Where reinforcement is used as a tension tie, splices shall be made with a full mechanical or full welded splice per ACI 318 Section 25.4.

2-4.1.3 1901.9 – Drying Shrinkage [Addition]

Concrete drying shrinkage shall be determined for the approved concrete mixture per ASTM C157/C157M as modified by ACI 364.3R and shall not exceed 0.05.

2-4.1.4 1901.10 – Lightweight Concrete Water Content [Addition]

All coarse lightweight aggregate used in a concrete mixture shall be saturated surface dry prior to mixing. The total allowable water in the concrete mixture shall account for the water in the aggregate and admixtures. The water-to-cementitious materials ratio shall not exceed 0.50.

2-4.2 Section 1904 - DURABILITY REQUIREMENTS

2-4.2.1 1904.3 - Corrosive Environments [Addition]

In a marine environment where concrete is subjected to salt-water wave action and spray, reinforcement protection shall be in accordance with ACI 357R.

2-4.3 Section 1906 – STRUCTURAL PLAIN CONCRETE

2-4.3.1 1906.1 - Scope [Deletion]

Delete the exception to this section in its entirety.

2-4.4 Section 1907 - MINIMUM SLAB PROVISIONS

2-4.4.1 1907.1 - General [Replacement]

Replace the first line of the paragraph to read: The thickness of concrete floor slabs supported directly on the ground shall not be less than 4 inches (102 mm).

2-4.4.2 1907.2 - Slab-on-Ground Design [Addition]

Slabs-on-ground shall be designed in accordance with ACI 360R, except slabs-on-ground supporting aircraft loading shall be designed in accordance with UFC 3-260-02.

2-4.4.2.1 1907.2.1 - Wall Loads on Slab-on-Ground [Addition]

Slabs-on-ground shall have adequate thickness to support wall line load as indicated in Tables 2-4 and 2-5. The thickened portion shall have a minimum width as shown in Figure 2-1.

2-4.4.2.2 1907.2.2 - Slab-on-Ground Over Permafrost [Addition]

Design and construction of slabs-on-ground over permafrost shall be in accordance with UFC 3-130-01 and UFC 3-130-04.

2-4.4.2.3 1907.2.3 - Post-Tensioned Slab-on-Ground [Addition]

The design of post-tensioned slabs-on-ground shall be in accordance with PTI DC10.1.

CANCELLED

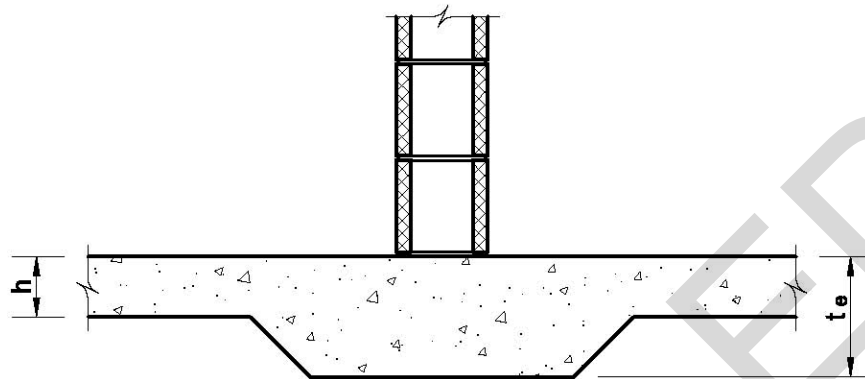
TABLE 2-4 - MAXIMUM ALLOWABLE WALL LOAD AT A THICKENED SLAB FOR WALL LOAD NEAR CENTER OF SLAB OR NEAR KEYED OR DOWELED JOINTS

Thickness of Thickened Floor Slab, t_e	Slab Line Load Capacity, P			
	Flexural Strength ^a of Concrete			
	550 psi (3.9 MPa)	600 psi (4.1 MPa)	650 psi (4.5 MPa)	700 psi (4.8 MPa)
4 in (102 mm)	425 lb/ft (6.2 kN/m)	455 lb/ft (6.6 kN/m)	485 lb/ft (7.1 kN/m)	510 lb/ft (7.4 kN/m)
5 in (127 mm)	565 lb/ft (8.2 kN/m)	600 lb/ft (8.8 kN/m)	640 lb/ft (9.3 kN/m)	675 lb/ft (9.9 kN/m)
6 in (152 mm)	710 lb/ft (10.4 kN/m)	755 lb/ft (11.0 kN/m)	805 lb/ft (11.7 kN/m)	850 lb/ft (12.4 kN/m)
7 in (178 mm)	860 lb/ft (12.6 kN/m)	920 lb/ft (13.4 kN/m)	975 lb/ft (14.2 kN/m)	1030 lb/ft (15.0 kN/m)
8 in (203 mm)	1015 lb/ft (14.8 kN/m)	1080 lb/ft (15.8 kN/m)	1150 lb/ft (16.8 kN/m)	1215 lb/ft (17.7 kN/m)
9 in (229 mm)	1175 lb/ft (17.1 kN/m)	1255 lb/ft (18.3 kN/m)	1330 lb/ft (19.4 kN/m)	1410 lb/ft (20.6 kN/m)
10 in (254 mm)	1340 lb/ft (19.6 kN/m)	1430 lb/ft (20.9 kN/m)	1520 lb/ft (22.2 kN/m)	1605 lb/ft (23.4 kN/m)

TABLE 2-5 - MAXIMUM ALLOWABLE WALL LOAD AT A THICKENED SLAB FOR WALL LOAD NEAR FREE EDGE

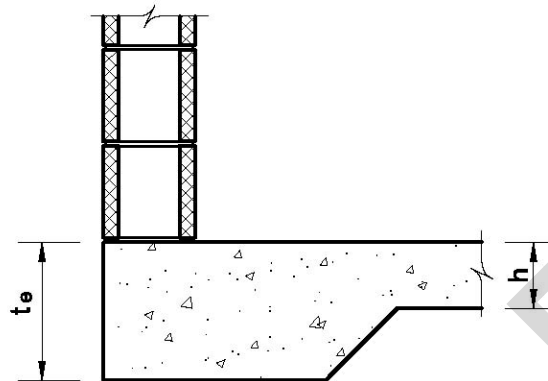

Thickness of Thickened Floor Slab, t_e	Slab Line Load Capacity, P			
	Flexural Strength ^a of Concrete			
	550 psi (3.9 MPa)	600 psi (4.1 MPa)	650 psi (4.5 MPa)	700 psi (4.8 MPa)
4 in (102 mm)	330 lb/ft (4.8 kN/m)	355 lb/ft (5.2 kN/m)	375 lb/ft (5.5 kN/m)	395 lb/ft (5.8 kN/m)
5 in (127 mm)	435 lb/ft (6.4 kN/m)	465 lb/ft (6.8 kN/m)	495 lb/ft (7.2 kN/m)	525 lb/ft (7.7 kN/m)
6 in (152 mm)	550 lb/ft (8.0 kN/m)	585 lb/ft (8.5 kN/m)	620 lb/ft (9.1 kN/m)	660 lb/ft (9.6 kN/m)
7 in (178 mm)	665 lb/ft (9.7 kN/m)	710 lb/ft (10.4 kN/m)	755 lb/ft (11.0 kN/m)	800 lb/ft (11.7 kN/m)
8 in (203 mm)	785 lb/ft (11.5 kN/m)	840 lb/ft (12.3 kN/m)	890 lb/ft (13.0 kN/m)	945 lb/ft (13.8 kN/m)
9 in (229 mm)	910 lb/ft (13.3 kN/m)	975 lb/ft (14.2 kN/m)	1035 lb/ft (15.1 kN/m)	1090 lb/ft (15.9 kN/m)
10 in (254 mm)	1040 lb/ft (15.2 kN/m)	1110 lb/ft (16.2 kN/m)	1180 lb/ft (17.2 kN/m)	1245 lb/ft (18.2 kN/m)

Notes for Table 2-4 and Table 2-5: The allowable wall loads are based on a modulus of subgrade reaction (k) of 100 pounds per cubic inch (27.1 MPa/m). The thickness of the thickened slab will be computed by multiplying the above thickness by a constant factor. Constants for other subgrade moduli are tabulated below.

Modulus of Subgrade Reaction (k)	25 pci (6.8 MPa/m)	50 pci (13.6 MPa/m)	100 pci (27.1 MPa/m)	200 pci (54.3 MPa/m)	300 pci (81.4 MPa/m)
Constant Factor	1.3	1.1	1.0	0.9	0.8

For other modulus of subgrade reaction values, the constant values may be considered equal to $\sqrt[5]{100/k}$, ($\sqrt[5]{27.1/k}$ metric).

^a For this application, the flexural strength of concrete was assumed equal to $9\sqrt{f'_c}$, ($0.75\sqrt{f'_c}$ metric) where f'_c is the specified compressive strength of concrete in pounds per square inch (MPa).

CANCELLED

FIGURE 2-1 - WIDTHS OF THICKENED SLABS AND SLAB EDGE CONDITIONS UNDER WALL LOADS

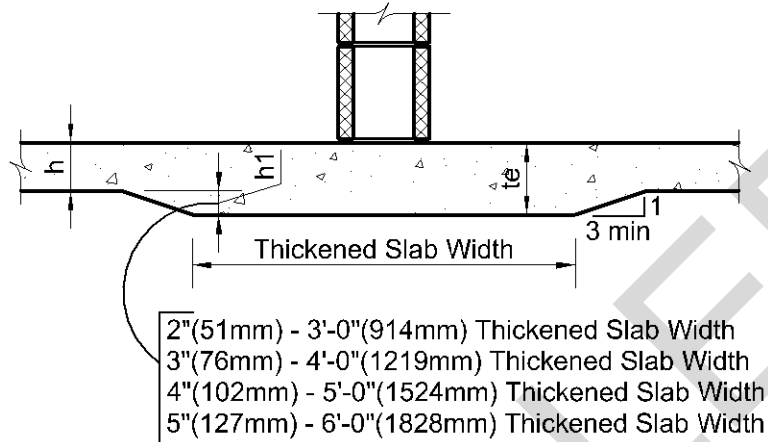

A) SLABS LOADED NEAR THE CENTER

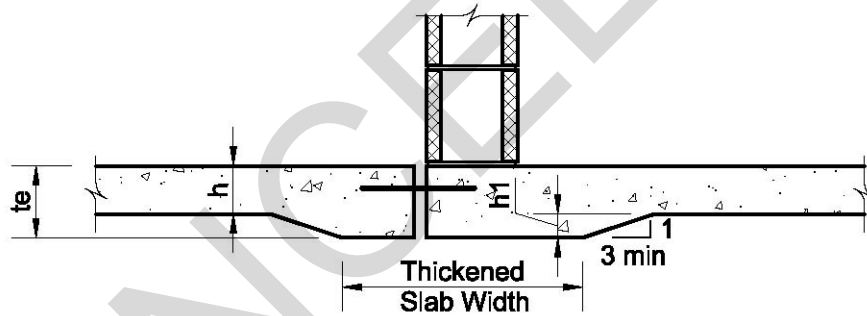

See Figure 2-1 (A) for slab width

B) SLABS LOADED NEAR A KEYED OR DOWELED JOINT

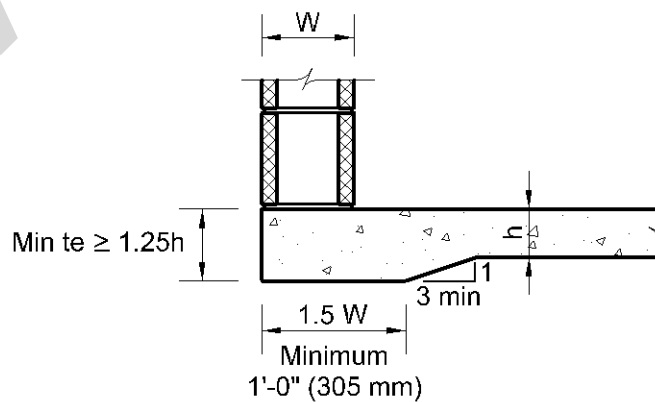

C) SLABS LOADED NEAR A FREE EDGE

2-5 CHAPTER 21 - MASONRY

2-5.1 Section 2101 - GENERAL

2-5.1.1 2101.2.1 - Allowable Stress Design [Addition]

Masonry shall be designed as reinforced unless the element is isolated from the structure so that vertical and lateral forces are not imparted to the element.

2-5.1.2 2101.2.2 - Strength Design [Addition]

Masonry shall be designed as reinforced unless the element is isolated from the structure so that vertical and lateral forces are not imparted to the element.

2-5.1.3 2101.2.3 - Empirical Design [Addition]

Masonry shall not be designed by the empirical method.

Renumber Section 2101.2.1 to 2101.2.4.

2\ /2/

2-5.1.4 2101.4 - Shear Wall Construction [Addition]

Shear walls shall be running bond construction only; stack bond construction is not permitted.

2-5.2 Section 2104 - CONSTRUCTION

2-5.2.1 2104.1.1 - Placing Mortar and Units [Addition]

Masonry walls below grade and elevator shaft walls shall be grouted solid.

2-5.2.2 2104.1.2 - Installation of Wall Ties [Addition]

Corrugated metal brick ties shall not be used.

2-5.2.3 2104.1.3 - Joint Reinforcement [Addition]

Horizontal wall reinforcement shall be continuous around wall corners and through wall intersections, unless the intersecting walls are separated. Reinforcement that is spliced in accordance with the applicable provisions of ACI 530 shall be considered continuous.

Renumber Sections 2104.1.1 and 2104.1.2 as 2104.1.4 and 2104.1.5, respectively.

2-5.2.4 2104.1.6 - Concrete Masonry Control Joints [Addition]

Spacing and placement of control joints shall be in accordance with NCMA TEK 10-2C or 10-3.

2-5.2.5 2104.1.7 - Vertical Brick Expansion Joints [Addition]

Spacing, placement, and size of vertical brick expansion joints shall be in accordance with BIA Technical Notes 18 and 18A.

2-5.3 Section 2109 - EMPIRICAL DESIGN OF MASONRY [Deletion]

This section shall be deleted in its entirety.

2-6 CHAPTER 22 - STEEL

2-6.1 Section 2204 - CONNECTIONS

2-6.1.1 2204.2 - Bolting [Supplement]

Add the following to the end of the paragraph: Compressible-washer-type direct tension indicators or twist-off-type tension-control bolts conforming to RCSC, *Specification for Structural Joints Using High-Strength Bolts* shall be provided at all bolted connections.

2-6.2 Section 2205 - STRUCTURAL STEEL

2-6.2.1 2205.1 - General [Supplement]

Add the following to the end of the paragraph: Structural steel floor framing systems shall be designed for vibration serviceability in accordance with AISC Design Guide 11.

2-6.2.2 2205.3 - Steel Structures in Corrosive Environments [Addition]

Steel structures or elements exposed to weather, salt spray or other corrosive environments shall be protected through coatings, galvanizing or the use of stainless alloy. Select the appropriate system or material to suit the anticipated exposure. For steel deck exposed to spray from salt, salt water, or brackish water, provide ASTM A653/A653M G90 galvanizing. For cold-formed steel members exposed to spray from salt, salt water, or brackish water, provide ASTM A653/A653M G90 galvanizing and connect with corrosion-resistant fasteners. See Section B-5.4 of UFC 3-301-01 for additional guidance.

2-6.3 Section 2210 - COLD-FORMED STEEL

2-6.3.1 2210.1.1.2 – Steel Roof Deck [Supplement]

Add the following to the end of the paragraph: Steel roof deck shall not be thinner than 22-gauge.

2-6.3.2 2210.1.1.4 - Steel Deck Diaphragms [Addition]

Design of steel deck diaphragms for in-plane and out-of-plane loads shall be in accordance with the SDI DDM03.

√\ /2/

2-6.4 Section 2211 - COLD-FORMED STEEL LIGHT-FRAMED CONSTRUCTION

2-6.4.1 2211.6.1 - Diagonal Bracing Material [Addition]

Diagonal bracing material shall be ASTM A653/A653M steel without rerolling, which induces strain hardening and reduces the elongation of the material and is therefore not desirable for performance under seismic loading.

2-6.4.2 2211.8 - Floor Vibrations [Addition]

Cold-formed steel framing systems shall be designed for vibration serviceability in accordance with the proposed design procedure in *Floor Vibration Design Criterion for Cold-Formed C-Shaped Supported Residential Floor Systems* by Kraus. The proposed design procedure is based on residential construction, but is applicable to all applications of cold-formed floor construction.

2-6.4.3 2211.9 - Brick Veneer/Steel Stud Walls [Addition]

Design of steel stud backup for brick veneer shall follow the recommendations from BIA Technical Note 28B. In particular, the recommendations for minimum stud gage, minimum galvanization, minimum anchorage of studs to track, welding of studs, use of deflection track, allowable stud deflection, wall sheathing, and water-resistant barrier shall be followed.

2-6.4.4 2211.10 - Cold-Formed Steel Connections [Addition]

Cold-formed steel members shall be interconnected with screw fasteners or by welding. The use of pneumatic nailing is permitted only for the connection of cold-formed members to members made of other materials.

2-6.4.5 2211.11 - Galvanized Cold-Formed Framing [Addition]

Cold-formed steel members exposed to spray from salt, salt water, brackish water, or seawater shall be galvanized per ASTM A653/A653M G90 and all fasteners shall be corrosion-resistant.

CHAPTER 3 MODIFICATIONS TO ASCE/SEI 7

3-1 CHAPTER 1 – GENERAL

\2\

3-1.1 1.3.1 – Strength and Stiffness [Supplement]

Add to the end of Item c.: During the design concept stage of development, documentation shall be submitted to the AHJ for approval of the performance based design approach.

/2/

3-1.2 1.3.1.3 – Performance Based Procedures [Replacement]

Structural and nonstructural components and their connections shall be demonstrated by a combination of analysis and testing to provide a reliability not less than that expected for similar components designed in accordance with the Strength Procedures of Section 1.3.1.1 when subject to the influence of dead, live, environmental, and other loads. Consideration shall be given to uncertainties in loading and resistance.

3-1.3 1.3.1.3.3 – Documentation [Replacement]

The procedures used to demonstrate compliance with this section and the results of analysis and testing shall be documented in one or more reports submitted for prior approval to the AHJ and to an independent peer review.

3-2 CHAPTER 2 – COMBINATIONS OF LOADS

3-2.1 2.3.5 – Load Combinations Including Self-Straining Loads [Supplement]

Add to the end of the paragraph: The effect of load T shall be taken into consideration on a structure, its impact on serviceability and long term performance of the facility shall be evaluated. For further information see ASCE/SEI 7 Section C2.3.5.

3-2.2 2.4.4 – Load Combinations Including Self-Straining Loads [Supplement]

Add to the end of the paragraph: The effect of load T shall be taken into consideration on a structure, its impact on serviceability and long term performance of the facility shall be evaluated. For further information see ASCE/SEI 7 Section C2.4.4.

3-2.3 2.5.1 – Applicability [Replacement]

Where required by UFC 4-023-03, strength and stability shall be checked to ensure that structures are capable of resisting the effects of progressive collapse with the load combinations provided in UFC 4-023-03.

3-2.4 2.5.2 – Load Combinations [Deletion]

This section shall be deleted in its entirety.

3-2.5 2.5.3 – Stability Requirements [Deletion]

This section shall be deleted in its entirety.

3-3 CHAPTER 7 – SNOW LOADS

3-3.1 7.4 – Sloped Roof Snow Loads, p_s [Supplement]

Add to the end of the paragraph: Where obstructions occur on the roof from equipment such as photovoltaic panels, lightning cable systems, etc., the potential for snow buildup around the obstructions shall be considered.

3-4 CHAPTER 11 – SEISMIC DESIGN CRITERIA

/2\

3-4.1 11.1.3 – Applicability [Supplement]

Add the following at the end of the section:
Building or structures that are not routinely occupied, but whose primary purpose supports human activities, such as training towers, shall not be classified as non-building structures unless specifically approved by the AHJ.

/2/

3-4.2 11.2 – Definitions [Replacement]

Replace the definition for Moment Frame with the following:

Moment Frame: A frame in which members and joints resist lateral forces by flexure as well as along the axis of the members. Moment frames are categorized as intermediate moment frames (IMF), ordinary moment frames (OMF), and special moment frames (SMF). /2\ Every joint shall be restrained against rotation. /2/

**3-5 CHAPTER 15 – SEISMIC DESIGN REQUIREMENTS FOR
NONBUILDING STRUCTURES**

3-5.1 15.4.5 – Drift Limitations [Replacement]

Non-building structures similar to buildings shall comply with lateral drift requirements as specified for buildings in Chapter 12, ASCE/SEI 7.

Exception: The drift limitations of Section 12.12.1 need not apply to non-building structures if a rational analysis acceptable to the AHJ indicates they can be exceeded without adversely affecting structural stability or attached or interconnected components and elements such as walkways and piping. P-delta effects shall be considered where critical to the function or stability of the structure.

CANCELLED

This page intentionally left blank.

CANCELLED

CHAPTER 4 OTHER STRUCTURES

4-1 HIGHWAY BRIDGE DESIGN

Design of highway bridges shall be in accordance with AASHTO LRFD Bridge Design Specifications. Design examples are available at <http://bridges.transportation.org/Pages/DESIGNEXAMPLES.aspx> and in the PCI Bridge Design Manual.

4-2 RAILROAD BRIDGE DESIGN

Design of railroad bridges shall be in accordance with the AREMA Manual for Railway Engineering.

4-3 TANKS FOR LIQUID STORAGE

Design of tanks for liquid storage shall be in accordance with NFPA 22, AWWA D100, AWWA D103, AWWA D110 and AWWA D120 as applicable.

4-4 TANKS FOR PETROLEUM STORAGE

Design of tanks for petroleum storage shall be in accordance with UFC 3-460-01.

4-5 ENVIRONMENTAL ENGINEERING CONCRETE STRUCTURES

Design of environmental engineering concrete structures shall be in accordance with ACI 350.

4-6 PRESTRESSED CONCRETE TANKS

Design of prestressed concrete tanks shall be in accordance with ACI 372R.

4-7 WATER TREATMENT FACILITIES

Design of water treatment facilities shall be in accordance with the WEF Manual of Practice 8.

4-8 TRANSMISSION TOWERS AND POLES

Design of transmission towers shall be in accordance with ASCE 10. Design of transmission poles shall be in accordance with IEEE Standards Association's National Electric Safety Code.

4-9 ANTENNA TOWERS

Design of antenna towers shall be in accordance with ANSI/TIA-222-G.

4-10 PEDESTRIAN BRIDGES

Design of pedestrian bridges shall be in accordance with the AASHTO LRFD Guide Specifications for Design of Pedestrian Bridges.

CANCELLED

APPENDIX A REFERENCES

AMERICAN ASSOCIATION OF STATE HIGHWAY AND TRANSPORTATION OFFICIALS

<http://www.transportation.org/>

LRFD Bridge Design Specifications, Customary U.S. Units

LRFD Guide Specifications for the Design of Pedestrian Bridges

AMERICAN CONCRETE INSTITUTE

<http://www.concrete.org/general/home.asp>

ACI 223R, Guide for the Use of Shrinkage-Compensating Concrete

ACI 224R, Control of Cracking in Concrete Structures

ACI 224.3R, Joints in Concrete Construction

ACI 302.1R, Guide for Concrete Floor and Slab Construction

ACI 302.2R, Guide for Concrete Slabs that Receive Moisture-Sensitive Flooring Materials

ACI 318-14, Building Code Requirements for Structural Concrete

ACI 350.4R, Design Considerations for Environmental Engineering Concrete Structures

ACI 350, Code Requirements for Environmental Engineering Concrete Structures

ACI 351.3R, Foundations for Dynamic Equipment

ACI 357R, Guide for the Design and Construction of Fixed Offshore Concrete Structures

ACI 360R, Guide to Design of Slabs-on-Ground

ACI 364.3R, Guide for Cementitious Repair Material Data Sheet

ACI 372R, Design and Construction of Circular Wire and Strand-Wrapped Prestressed Concrete Structures

AMERICAN INSTITUTE OF STEEL CONSTRUCTION

<http://www.aisc.org/>

AISC 360-10, Specification for Structural Steel Buildings

AISC Design Guide 1, Base Plate and Anchor Rod Design

AISC Design Guide 3, Serviceability Design Considerations for Steel Buildings, Second Edition

AISC Design Guide 11, Floor Vibrations Due to Human Activity

RCSC Specification for Structural Joints Using High-Strength Bolts

Shear Transfer in Exposed Column Base Plates, Ivan Gomez, Amit Kanvinde, Chris Smith and Gregory Deierlein

AMERICAN IRON AND STEEL INSTITUTE

<http://www.steel.org/>

Effective Lengths for Laterally Unbraced Compression Flanges of Continuous Beams Near Intermediate Supports, J. H. Garrett, Jr., G. Haaijer, and K. H. Klippstein, Proceedings, Sixth Specialty Conference on Cold-Formed Steel Structures (<http://www.cfssonline.org/>)

AMERICAN SOCIETY OF SAFETY ENGINEERS

<http://www.asse.org/>

ANSI/ASSE Z359, Fall Protection Code

ANSI/ASSE Z359.6, Specifications and Design Requirements for Active Fall Protection Systems

ANSI/ASSE A1264.1, Safety Requirements for Workplace Walking/Working Surfaces and Their Access; Workplace Floor, Wall and Roof Openings, Stairs and Guardrails Systems Standard

AMERICAN RAILWAY ENGINEERING AND MAINTENANCE-OF-WAY ASSOCIATION

<http://www.arema.org/>

Manual for Railway Engineering

AMERICAN SOCIETY OF CIVIL ENGINEERS

<http://www.asce.org>

ASCE/SEI 7-10 Including Supplement No. 1, Minimum Design Loads for Buildings and Other Structures

ASCE/SEI 10, Design of Latticed Steel Transmission Structures

ASCE/SEI 32, Design and Construction of Frost-Protected Shallow Foundations

ASCE/SEI 41-13, Seismic Evaluation and Retrofit of Existing Buildings

AMERICAN WATER WORKS ASSOCIATION

<http://www.awwa.org/>

AWWA D100, Welded Carbon Steel Tanks for Water Storage

AWWA D103, Factory-Coated Bolted Steel Tanks for Water Storage

AWWA D110, Wire- and Strand-Wound, Circular, Prestressed Concrete Water Tanks

AWWA D120, Thermosetting Fiberglass-Reinforced Plastic Tanks

ASM INTERNATIONAL (formerly American Society for Metals)

<http://www.asminternational.org/>

ASM Handbook Volume 13B Corrosion: Materials

ASTM INTERNATIONAL (formerly American Society for Testing and Materials)

<http://www.astm.org/>

ASTM A653/A653M, Standard Specification for Steel Sheet, Zinc-Coated (Galvanized) or Zinc-Iron Alloy-Coated (Galvannealed) by the Hot-Dip Process

ASTM C157/C157M, Standard Test Method for Length Change of Hardened Hydraulic-Cement Mortar and Concrete

BRICK INDUSTRY ASSOCIATION (formerly Brick Institute Of America)

<http://www.gobrick.com/>

BIA Technical Note 18, Volume Changes – Analysis and Effects of Movement

BIA Technical Note 18A, Accommodating Expansion of Brickwork

BIA Technical Note 28B, Brick Veneer/Steel Stud Walls

COLD REGIONS RESEARCH AND ENGINEERING LABORATORY

<http://www.erd.c.usace.army.mil/Locations/ColdRegionsResearchandEngineeringLaboratory.aspx>

Database and Methodology for Conducting Site Specific Snow Load Case Studies for the United States

FEDERAL EMERGENCY MANAGEMENT AGENCY

<http://www.fema.gov/>

FEMA P-361, Safe Rooms for Tornadoes and Hurricanes: Guidance for Community and Residential Safe Rooms, Third Edition (2015)

FEMA P-1026 / March 2015, Seismic Design of Rigid Wall – Flexible Diaphragm Buildings: An Alternate Procedure

INSTITUTE OF ELECTRICAL AND ELECTRONICS ENGINEERS

www.ieee.org

IEEE Standards Association, National Electric Safety Code (NESEC)

INTERNATIONAL CODE COUNCIL

<http://www.iccsafe.org/>

International Building Code, 2015 Edition

MCGRAW-HILL

<http://www.mhprofessional.com/>

Metal Building System Design and Specification, Alexander Newman

METAL BUILDING MANUFACTURERS ASSOCIATION

<http://www.mbma.com/>

Metal Building Systems Manual, 2012 Edition

NATIONAL ACADEMY OF SCIENCES

<http://www.nationalacademies.org/>

Technical Report No. 65, Expansion Joints in Buildings

NATIONAL CONCRETE MASONRY ASSOCIATION

<http://www.ncma.org>

TEK 10-2C, Control Joints for Concrete Masonry Walls – Empirical Method

TEK 10-3, Control Joints for Concrete Masonry Walls – Alternative Engineered Method

NATIONAL FIRE PROTECTION ASSOCIATION

<http://www.nfpa.org/>

NFPA 22, Standard for Water Tanks for Private Fire Protection

OCCUPATIONAL SAFETY & HEALTH ADMINISTRATION

<http://www.osha.gov/>

29 CFR, Part 1926, Safety and Health Regulations for Construction

29 CFR, Part 1910, Occupational Safety and Health Standards for General Industry

29 CFR, Part 1910, Notices of Proposed Rulemaking

POST-TENSIONING INSTITUTE

<http://www.post-tensioning.org/>

PTI DC10.1, Design of Post-Tensioned Slabs-on-Ground

PRECAST/PRESTRESSED CONCRETE INSTITUTE

<http://www.pci.org/>

PCI MNL-133, Bridge Design Manual, 3rd Edition

STEEL DECK INSTITUTE

<http://www.sdi.org/>

SDI DDM03, Diaphragm Design Manual Third Edition

STRUCTURAL ENGINEERS ASSOCIATION OF CALIFORNIA

<http://www.seaoc.org/>

SEAOC PV1-2012, Structural Seismic Requirements and Commentary for Rooftop Solar Photovoltaic Arrays

SEAOC PV2-2012, Wind Design for Low-Profile Solar Photovoltaic Arrays on Flat Roofs

TELECOMMUNICATIONS INDUSTRY ASSOCIATION

<http://www.tiaonline.org/>

ANSI/TIA-222-G, Structural Standards for Antenna Supporting Structures and Antennas

THE MASONRY SOCIETY

<http://www.masonrysociety.org/>

Masonry Standard Joint Committee's (MSJC), TMS 402-13/ACI 530-13/ASCE 5-13, TMS 602-13/ACI 530.1-13/ASCE 6-13, Building Code Requirements and Specification for Masonry Structures

UNITED STATES DEPARTMENT OF DEFENSE, UNIFIED FACILITIES CRITERIA

<http://dod.wbdg.org/>

UFC 1-200-01, DoD Building Code (General Building Requirements)

UFC 3-110-03, Roofing

UFC 3-130-01, General Provisions - Arctic and Subarctic Construction

UFC 3-130-04, Foundations for Structures - Arctic and Subarctic Construction

UFC 3-130-06, Calculation Methods for Determination of Depth of Freeze and Thaw in Soil – Arctic and Subarctic Construction

UFC 3-220-01, Geotechnical Engineering

UFC 3-260-02, Pavement Design for Airfields

UFC 3-310-04, Seismic Design of Buildings

UFC 3-320-06A, Concrete Floor Slabs on Grade Subjected to Heavy Loads

UFC 3-460-01, Design: Petroleum Fuel Facilities

UFC 4-010-01, DoD Minimum Antiterrorism Standards for Buildings

UFC 4-023-03, Design of Buildings to Resist Progressive Collapse

UFGS, Unified Facilities Guide Specifications

UNITED STATES GEOLOGICAL SURVEY

USGS National Center, Earthquake Hazards Program,
<http://geohazards.usgs.gov/designmaps/us/>

U.S. Seismic Design Maps Web Application, for the 2015 version of the International Building Code

VIRGINIA TECH
<http://www.vt.edu/>

Floor Vibration Design Criterion for Cold-Formed C-Shaped Supported Residential Floor systems, Master's Thesis, Cynthia A. Kraus

WATER ENVIRONMENT FEDERATION
<http://www.wef.org/>

WEF MOP 8, Design of Municipal Wastewater Treatment Plants

APPENDIX B BEST PRACTICES

B-1 STRUCTURAL DESIGN

B-1.1 Building Drift Limits

\2\ The topic of serviceability is addressed in IBC Section 1604.3 which requires: “Structural systems and members thereof shall have adequate stiffness to limit deflections and lateral drift.” However, the section is obviously focused on structural members, not an entire building or structure.

ASCE 7 Section 12.12 requires interstory drift caused by code-prescribed seismic forces to be within tolerable limits. These are the only mandatory building drift limits of the IBC.

ASCE 7 Appendix C, Serviceability Considerations, which is non-mandatory, states: “Lateral deflection or drift of structures and deformation of horizontal diaphragms and bracing systems due to wind effects shall not impair the serviceability of the structure.” The extensive commentary on this appendix discusses how the above objective might be accomplished, but leaves it to engineering judgment that should be exercised in consultation with the building client. /2/

. The establishment of acceptable drift limits and load combinations that must be considered in evaluating serviceability does require significant engineering judgment. Application of a requirement that is too stringent can significantly impact the cost of a structure. Requirements that are too lax can lead to damage of rigidly connected components.

The *Metal Building Systems Manual* provides guidance for allowable drift due to wind loads for pre-engineered metal buildings, and serviceability recommendations for metal buildings can also be found in Chapter L of AISC 360 with additional guidance in AISC *Steel Design Guide 3*.

When separate support columns are used for top-running cranes, they should be supported so that differential movement between the crane columns and building columns, due to differences in stiffness, does not overstress either column and result in local column buckling.

B-1.2 Impact Resistant Glazing

Buildings which are subjected to tornado winds can suffer some of the same missile impact damage to the exterior façade of the building as those located in windborne debris regions. The loss of glazing on a building due to missile impact can render the facility inoperable. The loss of glazing will also cause an increase in internal pressure in the building causing further damage. Consideration should be given to providing impact resistant glazing on facilities in tornado prone areas similar to what is required in

windborne debris regions. Tornado prone regions are the areas of the United States that have had five or more recorded EF3, EF4 or EF5 tornadoes per Figure 2-2 in FEMA P-361.

B-1.3 Hard Wall Buildings

In buildings constructed of load bearing tilt-up or precast structural walls, the loss of the roof diaphragm during a high wind event can lead to total collapse of the structure. The following are several possible methods to mitigate this hazard:

- Create enough fixity between the bottom of the panels and the foundation to provide stability to the wall panels in the event of the loss of the roof diaphragm.
- Limit the length of continuous wall panels between full height lateral cross bracing elements to better restrain the wall panels.
- Provide a system of robust continuous ties across the roof diaphragm to preserve the walls if the roof diaphragm fails.

∨\ FEMA has just issued an important publication, FEMA P-1026, on the seismic design of these buildings. /2/

B-1.4 Wind and Seismic Loads on Photovoltaic Arrays

∨\ The 2015 IBC has added Section 1510.7.1 on the wind resistance of rooftop-mounted photovoltaic panels and modules. /2/ Guidance on the design wind and seismic loads for rooftop-mounted photovoltaic arrays can be found in *Wind Design for Low-Profile Solar Photovoltaic Arrays on Flat Roofs* (SEAOC PV2-2012) and *Structural Seismic Requirements and Commentary for Rooftop Solar Photovoltaic Arrays* (SEAOC PV1-2012), prepared by the Structural Engineers Association of California Solar Photovoltaic Systems Committee. When designing support structures for photovoltaic arrays, review requirements in UFC 3-110-03 Roofing concerning roof mounted systems including the requirement that supports be permanently affixed to the structure, which means that ballasted systems are not permitted. ∨\ The 2015 IBC has added Section 1607.12.5 which requires that roof structures that provide support for photovoltaic panel systems be designed in accordance with that section. This section does not disallow ballasted systems. /2/

B-1.5 Wind Loads on Buildings with Large Openings

When determining wind loads on building containing large openings such as overhead doors in warehouses, maintenance shops, etc., it is recommended that the criteria for hangars in Section 2-1.5.2 of this UFC be used.

B-2 SOILS AND FOUNDATIONS

B-2.1 Gable Bent Footings

Moment frame reactions from metal building gable bents have horizontal thrusts at column bases which can be resisted by several methods. For large thrust forces (40 to 50 kips (118 kN to 222 kN)), tie rods are usually cost-effective. The tie rods can be embedded in a thickened slab or can be part of a tie beam between column foundations. For smaller thrust forces, hairpin reinforcing bars may be used to transfer the thrust force from the column anchor bolts into the slab-on-ground reinforcement, which acts as the tie between the columns. However, each of these methods requires close attention to detailing of \1\ /1/ joints in the slab, isolation joints around a foundation pier and other possible interruptions in the continuous slab reinforcement between columns. Also, future renovation that might require trenching across the continuous slab reinforcement could result in the loss of the tension tie. A third method is to design the foundation for an overturning moment due to the thrust force at the base of the column. Each of these methods can provide the necessary resistance to the thrust force, but needs to be evaluated for each project condition. For further discussion on the design of foundations for gable bent reactions, refer to *Metal Building System Design and Specification* by Alexander Newman.

B-2.2 Footings on Expansive Soils

In the presence of expansive soils, footings must be designed to withstand expansive soil movement in order to prevent significant damage to structures. Cyclical expansive soil movement from soil water content, usually caused by a combination of inadequate drainage and seasonal wetting and drying cycles, are especially troublesome. Base the design on soil testing and recommendations by qualified geotechnical engineers. Ensure soil investigations include estimates of settlement, heave, and recommendations to mitigate effects of expansive soil movement. Ensure positive drainage away from structures that will prevent ponding close to structures. Guidance on design of foundations on expansive soils can be found in UFC 3-220-01.

B-2.3 Footings Depth Due to Frost

The depth to which frost penetrates at a site depends on the climate, the type of soil, the moisture in the soil and the surface cover (e.g., pavement kept clear of snow vs. snow covered turf). If the supporting soil is warmed by heat from a building, frost penetration is reduced considerably. The values in Tables E-2 and F-2 represent the depth of frost penetration to be expected if the ground is bare of vegetation and snow cover, the soil is non-frost susceptible (NFS), well-drained (i.e., dry) sand or gravel, and no building heat is available. Thus, these values represent the deepest (i.e., worst case) frost penetration expected in each area. Most building foundations can be at a shallower depth without suffering frost action. (However, other considerations besides frost penetration may affect foundation depth, such as erosion potential or moisture desiccation). For interior footings, which under service conditions are not normally

susceptible to frost, the potential effects of frost heave during construction should be considered. Design values for heated and unheated buildings may be obtained by reducing the values in Tables E-2 and F-2 according to Figure B-1. For buildings heated only infrequently, the curve in Figure B-1 for unheated buildings should be used. The curves in Figure B-1 were established with an appreciation for the variability of soil and the understanding that some portions of the building may abut snow-covered turf while other portions abut paved areas kept clear of snow. Foundations should be placed at or below the depths calculated above. The foundation of heated buildings may be placed at a shallower depth than calculated above if protected from frost action by insulation on the cold side, see Figure C1 of SEI/ASCE 32. For more information on the design of foundation insulation, see SEI/ASCE 32. Additional information on which more refined estimates of frost penetration can be made, based on site-specific climatic information, the type of ground cover, and soil conditions, is contained in UFC 3-130-06.

Figure B-1 Footing Depth Example: The minimum depth needed for footings of a hospital and an unheated vehicle storage building to be built in Fort Drum, New York, is calculated to protect them from frost action. The tabulated frost penetration value for Fort Drum is 94 inches (Table E-2). Using the “heated” curve in Figure B-1, footings for the hospital should be located 4 feet below the surface. Using the “unheated” curve, footings for the unheated garage should be located 5.5 feet below the surface.

B-3 CONCRETE

B-3.1 Slab-on-Ground Concrete Strength

For slabs-on-ground subject to forklift traffic, it is recommended that the minimum compressive strength for the concrete be 4,000 psi (27.6 MPa) for pneumatic tire traffic and 5,000 psi (34.5 MPa) for steel tire traffic.

\1\

B-3.2 Slab-on-Ground Joints

/1/

For slabs-on-ground, it is recommended that the \1\ /1/ joints align across the building floor plate to avoid joints ending abruptly at the edge of a panel. Joints that end abruptly at an adjacent panel edge could cause a crack to propagate into the adjacent panel. For locations where placement of joints at a panel edge are unavoidable, refer to UFC 3-320-06A for additional reinforcement requirements to minimize crack propagation.

Location of \1\ /1/ joints in slabs-on-ground need to be coordinated with the joints in hard-surface finishes to avoid having the \1\ /1/ joints telegraph through the hard-surface finish.

FIGURE B-1 – DESIGN DEPTH OF BOTTOM OF BUILDING FOUNDATION

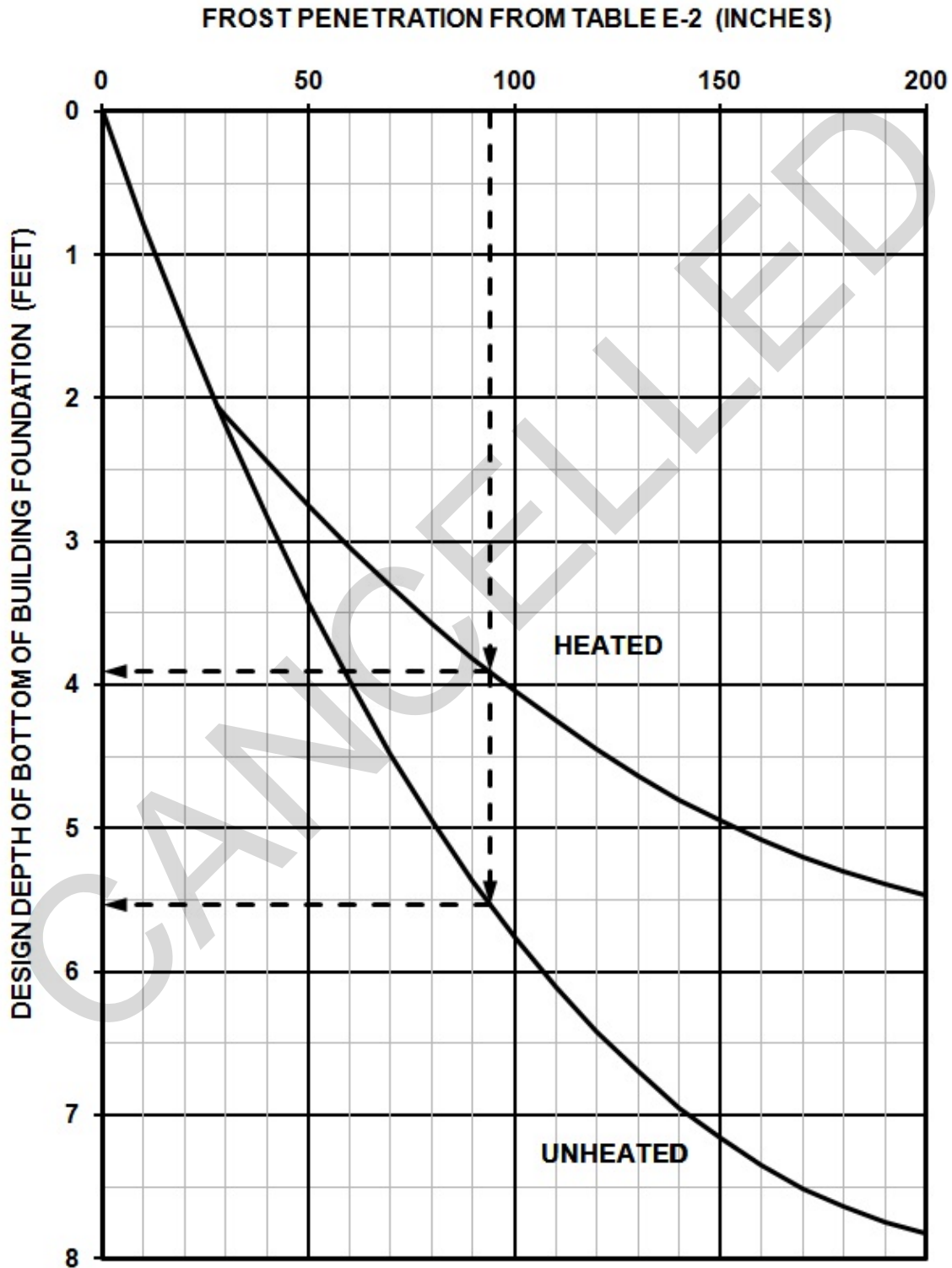

B-3.3 Slab-on-Ground Drying Shrinkage

Cracking in slabs generally results from drying shrinkage and restraint caused by friction between the slab and subgrade. Curling and warping occur due to differential shrinkage when the top of the slab dries to lower moisture content than the bottom of the slab. Recommendations for reducing the effects of drying shrinkage can be found in ACI 360R, ACI 224R, and ACI 302.1R. Shrinkage compensating concrete can also be used to reduce shrinkage cracking. See recommendations in ACI 223R.

B-3.4 Slab-on-Ground Vapor Retarder/Barrier

To facilitate proper moisture control of a slab-on-ground to meet the moisture limits of water-based adhesives and durability during construction, it is recommended that the vapor retarder have a minimum thickness of 10 mil (250 μm) with a maximum permeance rating of 0.04 perm. Where moisture is a critical issue under the floor covering, such as wood floors, and a vapor barrier required, it is recommended to reduce the maximum permeance rating to 0.01 perm. For further guidance on slabs to receive moisture-sensitive floor coverings refer to ACI 302.2R. Note that the 2015 IBC has minimum vapor barrier requirements in Section 1907.

B-3.5 Post-Installed Adhesive Concrete Anchors

It is recommended that adhesive anchors be proof loaded during special inspections of critical anchors to the lesser of 50 percent of the expected peak load based on adhesive bond strength or 80 percent of the anchor yield strength with the proof load being sustained for a minimum of 10 seconds.

B-4 MASONRY

B-4.1 Masonry Veneer Base Detail

The base of the masonry veneer should be placed on a shelf angle or a foundation ledge that is lower than the base of the steel stud wall by at least 4 inches (102 mm). The width of this shelf angle or foundation ledge will include the width of the masonry veneer and the cavity. This width should not be less than two-thirds of the veneer thickness plus the minimum air space.

B-5 STEEL

B-5.1 Shelf Angles for Masonry

Shelf angles should be hot-dip galvanized structural steel members. Angles should be provided in segments approximately 10 feet (3 m) in length, with gaps between segments. Shelf angles should be detailed to allow enough gaps for thermal expansion and contraction of the steel in angle runs and at building corners. Corners of buildings should have corner pieces with each leg no less than 4 feet (1.2 m) in length where possible.

Limit deflection of horizontal legs of shelf angles under masonry loading to 1/16 inch (1.6 mm) at the end of the horizontal leg. Rotation of the shelf angle support should be included in the horizontal leg displacement calculation.

B-5.2 Cold-Formed Continuous Beams and Joists

Guidance on determining the effective length of the unbraced compression flange for cold-formed continuous beams and joists can be found in AISI *Effective Lengths for Laterally Unbraced Compression Flanges of Continuous Beams Near Intermediate Supports*.

B-5.3 Masonry Veneer/Steel Stud Wall Detailing

Recommended details for masonry veneer/steel stud wall assemblies can be found in BIA Technical Note 28B.

B-5.4 Steel Structures in Corrosive Environments

Steel structures designed for corrosive environments should include consideration of the following corrosion protection measures:

- a. Box-shaped members should be designed so that all inside surfaces may be readily inspected, cleaned, and painted, or should be closed entirely, except when hot-dip galvanized, to prevent exposure to moisture.
- b. The legs of two back-to-back angle members, when not in contact, should have a minimum separation of 3/8 inch (9.5 mm) to permit air circulation.
- c. Pockets or depressions in horizontal members should have drain holes to prevent water from ponding in low areas. Positive drainage should be provided away from exposed steel. Column bases should be terminated on concrete curbs or piers above grade, and tops of curbs or piers should be pitched to drain.
- d. Where extremely corrosive conditions exist, consideration should be given to providing cathodic protection in addition to protective coatings for steel members exposed to salt water moisture environments.
- e. Structural members embedded in concrete and exterior railing, handrails, fences, guardrails, and anchor bolts should be galvanized or constructed of stainless steel.
- f. Dissimilar metals, (e.g., aluminum and steel, stainless steel and carbon steel, zinc-coated steel and uncoated steel) should be isolated by appropriate means to avoid the creation of galvanic cells which can occur when dissimilar metals come in contact.

- g. Consult a corrosion specialist certified by NACE International to recommend material protection for elements exposed to heavy industrial pollution, chemicals, or corrosive soils.
- h. For increased serviceability and compatibility with fireproofing, use galvanized steel deck in accordance with ASTM A653/A653M.
- i. Note that some common grades of stainless alloy such as ASTM Type 306 or 316 are susceptible to corrosion when immersed in salt or brackish water.

Further guidance for designing steel structures in corrosive environments can be found in *ASM Handbook Volume 13B*.

B-5.5 Steel Structures in Arctic and Antarctic Zones

For carbon steel, the transition from ductile to brittle behavior occurs within temperatures to be expected in Arctic and Antarctic zones. Ductility is important for structures in high seismic areas. Toughness, a characteristic also affected by cold temperatures, is important for structures which could be subjected to cyclic or impact loads. Design of structures which could be subjected to cyclic or impact loads in cold climates should include consideration of the following measures to mitigate potential fatigue and fracture problems:

- a. Provide ample fillets to avoid stress risers.
- b. Use bolted joints whenever possible. If welded joints are used, take precautions to eliminate gas and impurities in welds. Proper preheating and post-cooling are essential.
- c. Use low-carbon steels and nickel-alloy steels that have good toughness characteristics at low temperatures.

B-5.6 Steel Column Base Plate Shear Transfer

Shear transfer between column base plates and the concrete foundation elements can be accomplished through several load paths including shear friction between the base plate and grout, anchor rod bearing or shear key bearing. The design provisions in *AISC Design Guide 1: Base Plate and Anchor Rod Design* should be followed when designing base plates for shear. Research and full scale testing of base plates in shear, conducted at the University of California, Berkeley, provide further guidance on recommended shear friction coefficient, anchor rod bending length, and concrete capacity design of shear key bearing. Results of the testing can be found in the research report *Shear Transfer in Exposed Column Base Plates*, published by AISC.

B-5.7 Steel Joist Connections

Connections between open web steel joists and supporting girders or joist girders and building columns are in many instances covered by typical details provided by the joist supplier, which may not provide the needed capacity for lateral or uplift loading. Each joist connection should be designed specifically for the project and take into consideration the lateral and uplift loads acting on the connection.

B-6 WOOD

B-6.1 Connections

When using prescriptive guidelines in building codes for nailed wood connections, careful consideration needs to be given to ensure a complete load path from the roof to the foundation. The use of metal plate connections for roof trusses, top plates and sill plates is an effective way to provide a more robust load path.

CANCELLED

This page intentionally left blank.

CANCELLED

APPENDIX C ABBREVIATIONS

AASHTO American Association of State Highway and Transportation Officials
ACI American Concrete Institute
AHJ Authority Having Jurisdiction
AISC American Institute of Steel Construction
ANSI American National Standards Institute
AOB Air Operations Building
AREMA American Railway Engineering and Maintenance-of-Way Association
ASCE American Society of Civil Engineers
ASM American Society for Metals
ASTM American Society of Testing and Materials
ATCT Air Traffic Control Tower
AWWA American Water Works Association
BIA Brick Industry Association
CRREL Cold Regions Research and Engineering Laboratory
CS Case Study
DoD Department of Defense
∅\ DOR Designer of Record /2/
%g Percent of Gravity
FEMA Federal Emergency Management Agency
IBC International Building Code
ICC-ES International Code Council – Evaluation Services
IMF Intermediate Moment Frame

in	Inches
kg	Kilogram
kg/m³	Kilograms per Cubic Meter
km/h	Kilometers per Hour
kN	Kilonewton
kN/m	Kilonewton per Meter
kN/m²	Kilonewton per Square Meter
kPa	Kilopascal
lbs	Pounds
lb/ft	Pounds per Foot
lb/ft²	Pounds per Square Foot
lb/in²	Pounds per Square Inch
m	Meter
m²	Square Meter
m/s	Meters per Second
mil	0.001 Inch
mm	Millimeter
mm²	Square Millimeter
MCE_R	Risk-Targeted Maximum Considered Earthquake
MPa	Megapascal
MPa/m	Megapascal per Meter
mph	Miles per Hour
MRI	Mean Recurrence Interval

- NACE** National Association of Corrosion Engineers
- NCMA** National Concrete Masonry Association
- NFPA** National Fire Protection Association
- NFS** Non-Frost Susceptible
- OMF** Ordinary Moment Frame
- pci** Pounds per Cubic Inch
- PGA** Maximum Considered Earthquake Geometric Mean (MCE_G) Peak Ground Acceleration as defined in ASCE 7-10
- psf** Pounds per Square Foot
- psi** Pounds per Square Inch
- PSSQ** Project Specific Seismic Qualification
- RACF** Radar Approach Control Facility
- RCSC** Research Council on Structural Connections
- S_s** Risk-Targeted Maximum Considered Earthquake (MCE_R) 0.2-Second Spectral Response Acceleration as determined by IBC Section 1613.3.1
- S_1** Risk-Targeted Maximum Considered Earthquake (MCE_R) 1.0-Second Spectral Response Acceleration as determined by IBC Section 1613.3.1
- $S_{s,5/50}$** Short-period (0.2-second) spectral response acceleration with a 5% probability of being exceeded in 50 years. For reduced “BSE-2E” hazard for existing buildings to be used with target performance objectives as defined in ASCE 41-13. In accordance with ASCE 41-13, the short period BSE-2E spectral response acceleration need not be greater than S_s modified for site class (“BSE-2N”).
- $S_{1,5/50}$** Long-period (1.0-second) spectral response acceleration with a 5% probability of being exceeded in 50 years. For reduced “BSE-2E” hazard for existing buildings to be used with target performance objectives as defined in ASCE 41-13. In accordance with ASCE 41-13, the 1.0-second BSE-2E spectral response acceleration need not be greater than S_1 modified for site class (“BSE-2N”).

- $S_{S,10/50}$** Short-period (0.2-second) spectral response acceleration with a 10% probability of being exceeded in 50 years
- $S_{1,10/50}$** Long-period (1.0-second) spectral response acceleration with a 10% probability of being exceeded in 50 years
- $S_{S,20/50}$** Short-period (0.2-second) spectral response acceleration with a 20% probability of being exceeded in 50 years. Reduced “BSE-1E” hazard for existing buildings to be used with target performance objectives as defined in ASCE 41-13. In accordance with ASCE 41-13, the short period BSE-1E spectral response acceleration need not be greater than 2/3 of S_S modified for site class (“BSE-1N”).
- $S_{1,20/50}$** Long-period (1.0-second) spectral response acceleration with a 20% probability of being exceeded in 50 years. Reduced “BSE-1E” hazard for existing buildings to be used with target performance objectives as defined in ASCE 41-13. In accordance with ASCE 41-13, the 1.0-second BSE-1E spectral response acceleration need not be greater than 2/3 of S_1 modified for site class (“BSE-1N”).
- SEAOC** Structural Engineers Association of California
- SIOR** Special Inspector of Record
- SMF** Special Moment Frame
- SWR** Special Wind Region
- UFC** Unified Facilities Criteria
- UFGS** Unified Facilities Guide Specifications /2/
- μm** micrometer (micron)
- V_{ASD}** Nominal Design Wind Speed
- V_{FM}** Fastest Mile Wind Speed
- V_{ULT}** Ultimate Design Wind Speed
- WEF** Water Environment Federation

**APPENDIX D MINIMUM UNIFORMLY DISTRIBUTED LIVE LOADS, L_o, AND
MINIMUM CONCENTRATED LIVE LOADS**

D-1 REFERENCES.

All section references are to the International Building Code (IBC) 2015. Table D-1 includes 2015 IBC Table 1607.1 with additional Occupancy or Use classification for military facilities that are shown in bold italics.

**TABLE D-1 MINIMUM UNIFORMLY DISTRIBUTED LIVE LOADS AND MINIMUM
CONCENTRATED LIVE LOADS^g**

OCCUPANCY OR USE	UNIFORM		CONCENTRATED	
	(kPa)	(psf)	(kN)	(lbs.)
1. Apartments (see residential)	---	---	---	---
2. Access floor systems				
Office use	2.4	50	8.9	2,000
Computer use	4.8	100	8.9	2,000
3. Ammunition Storage				
<i>High explosives (one story)</i>	23.9	500	---	---
<i>Inert explosives (one story)</i>	23.9	500	---	---
<i>Pyrotechnics (one story)</i>	23.9	500	---	---
<i>Small arms (one story)</i>	23.9	500	---	---
<i>Torpedo (one story)</i>	16.8	350	---	---
4. Armories and drill rooms	7.2 ^m	150 ^m	---	---
5. Assembly areas				
Fixed seats (fastened to floor)	2.9 ^m	60 ^m	---	---
Follow spot, projection and control rooms	2.4	50	---	---
Lobbies	4.8 ^m	100 ^m	---	---
Movable seats	4.8 ^m	100 ^m	---	---
Stage floors	7.2 ^m	150 ^m	---	---
Platforms (assembly)	4.8 ^m	100 ^m	---	---
Other assembly areas	4.8 ^m	100 ^m	---	---
6. Balconies and decks ^h	4.8	100	---	---
<i>(Balconies serving as primary means of egress for multiple rooms shall be considered as corridors.)</i>				
7. Battery charging room	9.6	200	---	---
8. Boiler houses	9.6	200	---	---
9. Catwalks	1.9	40	1.33	300
10. Cleaning gear / trash room compactor	3.6	75	---	---
11. Cold Storage (Food or provision freezer)				
<i>First floor</i>	19.2	400	---	---
<i>Upper floors</i>	14.4	300	---	---
12. Command Duty Officer Day room	2.9	60	---	---

OCCUPANCY OR USE	UNIFORM		CONCENTRATED	
	(kPa)	(psf)	(kN)	(lbs.)
13. Cornices	2.9	60	---	---
14. Corridors				
First floor	4.8	100	---	---
Other floors	Same as occupancy served except as indicated	Same as occupancy served except as indicated		
15. Court rooms	3.8	80	---	---
16. Dining rooms and restaurants	4.8 ^m	100 ^m	---	---
17. Decks – (See Item 6.)				
18. Dwellings (see residential)	---	---	---	---
19. Elevator machine room grating (on area of 50.8 mm x 50.8 mm (2 in. x 2 in.))	---	---	1.33	300
20. Finish light floor plate construction (on area of 25.4 mm x 25.4 mm (1 in. x 1 in.))	---	---	0.89	200
21. Fire escapes	4.8	100	---	---
On single-family dwellings only	1.9	40		
22. Galleys				
Dishwashing rooms	14.4	300		
General kitchen area	12.0	250		
Provision storage (not refrigerated)	9.6	200	---	---
Preparation room				
Meat	12.0	250		
Vegetable	4.8	100		
23. Garages (passenger vehicles only)	1.9 ^m	40 ^m	Note a	Note a
Trucks & buses	See Section 1607.7 - IBC	See Section 1607.7 - IBC	See Section 1607.7 - IBC	See Section 1607.7 - IBC
24. Generator rooms	9.6	200	---	---
25. Guard House	3.6	75	---	---
26. Handrails, guards and grab bars	See Section 1607.8 - IBC	See Section 1607.8 - IBC	See Section 1607.8 - IBC	See Section 1607.8 - IBC
27. Helipads ⁿ	See Section 1607.6 - IBC	See Section 1607.6 - IBC	See Section 1607.6 - IBC	See Section 1607.6 - IBC
28. Hospitals				
Corridors above first floor	3.8	80	4.45	1,000
Operating rooms, laboratories	2.9	60	4.45	1,000
Patient rooms	1.9	40	4.45	1,000
29. Hotels (see residential)	---	---	---	---
30. Incinerators; charging room	7.2	150	---	---
31. Laboratories, normal scientific equipment	6.0	125	---	---
32. Latrines / Heads / Toilets / Washroom	3.6	75	---	---

OCCUPANCY OR USE	UNIFORM		CONCENTRATED	
	(kPa)	(psf)	(kN)	(lbs.)
33. Libraries				
Reading rooms	2.9	60	4.45	1,000
Stack rooms	7.2 ^{b,m}	150 ^{b,m}	4.45	1,000
Corridors above first floor	3.8	80	4.45	1,000
34. Manufacturing				
Light	6.0 ^m	125 ^m	8.9	2,000
Heavy	12.0 ^m	250 ^m	13.34	3,000
35. Marquees, except one- and two-family dwellings	3.6	75	---	---
36. Mechanical equipment room (general)^p	4.8	100	---	---
37. Mechanical room (HVAC)	6.0	125	---	---
38. Mechanical telephone and radio equipment room	7.2	150	---	---
39. Morgue	4.8	100	---	---
40. Office buildings				
File and computer rooms shall be designed for heavier loads based on anticipated occupancy	---	---	---	---
Lobbies and first floor corridors	4.8	100	8.9	2,000
Offices	2.4	50	8.9	2,000
Corridors above first floor	3.8	80	8.9	2,000
41. Penal Institutions				
Cell blocks	1.9	40	---	---
Corridors	4.8	100	---	---
42. Post offices				
General area	4.8	100	---	---
Work rooms	6.0	125	---	---
43. Power plants	9.6	200	---	---
44. Projection booths	4.8	100	---	---
45. Pump houses	4.8	100	---	---
46. Recreation room	4.8	100	---	---
47. Recreational uses:				
Bowling alleys, poolrooms and similar uses	3.6 ^m	75 ^m	---	---
Dance halls and ballrooms	4.8 ^m	100 ^m	---	---
Gymnasiums	4.8 ^m	100 ^m	---	---
Reviewing stands, grandstands and bleachers	4.8 ^{c,m}	100 ^{c,m}	---	---
Stadiums and arenas with fixed seats (fastened to floor)	2.9 ^{c,m}	60 ^{c,m}	---	---
48. Receiving rooms (radio) including roof areas supporting antennas and electronic equipment	7.2	150	---	---
49. Refrigeration storage rooms				
Dairy	9.6	200	---	---
Meat	12.0	250	---	---
Vegetable	13.2	275	---	---

OCCUPANCY OR USE	UNIFORM		CONCENTRATED	
	(kPa)	(psf)	(kN)	(lbs.)
50. Residential				
One & two family dwellings				
Uninhabitable attics without storage ⁱ	0.5	10	---	---
Uninhabitable attics with storage ^{i,j,k}	1.0	20	---	---
Habitable attics and sleeping areas ^k	1.4	30	---	---
Canopies, including marquees	1.0	20	---	---
All other areas	1.9	40	---	---
Hotels and multifamily dwellings				
Private rooms & corridors serving them	1.9	40	---	---
Corridors serving as primary means of egress to multiple private rooms	3.8	80	---	---
Public rooms ^m and corridors serving them	4.8	100	---	---
51. Roofs				
All roof surfaces subject to maintenance workers	---	---	1.33	300
Awnings and canopies:				
Fabric construction supported by a skeleton structure	0.23	5	---	---
All other construction, except one and two-family dwellings	1.0	20	---	---
Ordinary flat, pitched, and curved roofs (that are not occupiable)	1.0	20	---	---
Where primary roof members are exposed to a work floor at single panel point of lower chord of roof trusses or any point along primary structural members supporting roofs:				
Over manufacturing, storage warehouses, and repair garages	---	---	8.9	2000
All other primary roof members	4.8	100	---	---
Occupiable roofs:				
Roof gardens	Note I	Note I	Note I	Note I
Assembly areas	1.0	20		
All other similar areas				
Roof of PV shade structures				
52. Schools				
Classrooms	1.9	40	4.45	1,000
Corridors above first floor	3.8	80	4.45	1,000
First floor corridors	4.8	100	4.45	1,000

OCCUPANCY OR USE	UNIFORM		CONCENTRATED	
	(kPa)	(psf)	(kN)	(lbs.)
53. Scuttles, skylight ribs, and accessible ceilings	---	---	0.89	200
54. Shops: Manufacturing and Industrial				
<i>Aircraft utility</i>	9.6	200	---	---
<i>Assembly and repair</i>	12.0	250	---	---
<i>Bombsight (w/o shielding)</i>	6.0	125	---	---
<i>Carpenter</i>	6.0	125	---	---
<i>Electrical</i>	14.4	300	---	---
<i>Engine overhaul</i>	14.4	300	---	---
55. Sidewalks, vehicular driveways and yards, subject to trucking	12.0 ^{d,m}	250 ^{d,m}	35.6 ^e	8,000 ^e
56. Stairs and exits				
One- and two-family dwellings	1.9	40	1.3 ^f	300 ^f
All other	4.8	100	1.3 ^f	300 ^f
57. Storage warehouses (shall be designed for heavier loads if required for anticipated storage)				
General				
Light	6.0 ^m	125 ^m		
Heavy	11.97 ^m	250 ^m		
<i>Aircraft</i>	9.58	200	---	---
<i>Building Materials</i>	11.97	250		
<i>Drugs, paint, oil</i>	9.58	200		
<i>Dry Provisions</i>	14.36	300		
<i>Groceries, wine, Liquor</i>	14.36	300		
<i>Light Tools</i>	7.2	150		
<i>Pipe & metal</i>	47.88	1000		
<i>Paint and oil (one story)</i>	23.94	500		
<i>Hardware</i>	14.36	300		
58. Stores				
Retail				
First floor	4.8	100	4.45	1,000
Upper floors	3.6	75	4.45	1,000
Wholesale, all floors	6.0 ^m	125 ^m	4.45	1,000
59. Tailor shop	3.6	75	---	---
60. Telephone exchange rooms and central computer IT server spaces	7.2	150	8.9	2000
61. Vehicle barriers	See Section 1607.8.3 - IBC	See Section 1607.8.3 - IBC	See Section 1607.8.3 - IBC	See Section 1607.8.3 - IBC
62. Walkways and elevated platforms (other than exit ways)				
<i>Range Towers, Climbing Towers and other Multi-story Training Towers</i>	2.9	60	---	---
<i>Pedestrian Bridges</i>	4.8	100		
	AASHTO^o	AASHTO^o		
63. Yards and terraces, pedestrian	4.8 ^m	100 ^m	---	---

Notes to Table D-1, "MINIMUM UNIFORMLY DISTRIBUTED LIVE LOADS, L_o , AND MINIMUM CONCENTRATED LIVE LOADS"

For SI: 1 inch = 25.4 mm, 1 square inch = 645.16 mm², 1 square foot = 0.0929 m², 1 pound per square foot = 0.0479 kN/m² = 0.0479 kPa, 1 pound = 0.004448 kN, 1 pound per cubic foot = 16 kg/m³.

- a. Floors in garages or portions of building used for the storage of motor vehicles shall be designed for the uniformly distributed live loads of this table or the following concentrated loads: (1) for garages restricted to passenger vehicles accommodating not more than nine passengers, 3,000 pounds (13.34 kN) acting on an area of 4.5 inches x 4.5 inches (114 mm x 114 mm); (2) for mechanical parking structures without slab or deck which are used for storing passenger vehicles only, 2,250 pounds (10.0 kN) per wheel.
- b. The loading applies to stack room floors that support non-mobile, double-faced library book stacks, subject to the following limitations:
 - 1) The nominal book stack unit height shall not exceed 90 inches (2,290mm).
 - 2) The nominal shelf depth shall not exceed 12 inches (305mm) for each face; and
 - 3) Parallel rows of double-faced book stacks shall be separated by aisles not less than 36 inches (915 mm) wide.
- c. Design in accordance with the ICC 300.
- d. Other uniform loads in accordance with an approved method containing provisions for truck loadings shall also be considered where appropriate.
- e. The concentrated wheel load shall be applied on an area of 4.5 inches by 4.5 inches (114mm x 114mm).
- f. The minimum concentrated load on stair treads shall be applied on an area of 2 inches by 2 inches (51mm x 51mm). This load need not be assumed to act concurrently with the uniform load.
- g. Where snow loads occur that are in excess of the design conditions, the structure shall be designed to support the loads due to the increased loads caused by drift buildup or a greater snow design determined by the AHJ. (See IBC Section 1608).
- h. See IBC Section 1604.8.3 for decks attached to exterior walls.
- i. Uninhabitable attics without storage are those where the maximum clear height between the joist and rafter is less than 42 inches (1067 mm), or where there are not two or more adjacent trusses with the same web configuration capable of accommodating an assumed rectangle 42 inches (1067 mm) high by 24 inches (610 mm) in width, or greater, within the plane of the truss. This live load need not be assumed to act concurrently with any other live load requirements.
- j. Uninhabitable attics with storage are those where the maximum clear height between the joist and rafter is 42 inches (1067 mm) or greater, or where there are

two or more adjacent trusses with the same web configuration capable of accommodating an assumed rectangle 42 inches (1067 mm) high by 24 inches (610 mm) in width, or greater, within the plane of the trusses.

The live load need only be applied to those portions of the joists or truss bottom chords where both of the following conditions are met:

- 1) The attic area is accessible from an opening not less than 20 inches (508 mm) in width by 30 inches (762 mm) in length that is located where the clear height in the attic is a minimum of 30 inches (762 mm); and
- 2) The slopes of the joists or truss bottom chords are no greater than two units vertical in 12 units horizontal.

The remaining portions of the joist or truss bottom chords shall be designed for a uniformly distributed concurrent live load of not less than 10 psf (0.5 kPa).

- k. Attic spaces served by stairways other than the pull-down type shall be designed to support the minimum live load specified for habitable attics and sleeping rooms.
- l. Areas of occupiable roofs, other than roof gardens and assembly areas, shall be designed for appropriate loads as approved by the AHJ. Unoccupied landscaped areas of roof shall be designed in accordance with IBC Section 1607.12.3.
- m. Live load reduction is not permitted unless specific exceptions of IBC Section 1607.10 apply.
- n. Helipads supporting military aircraft shall be designed to support the actual aircraft weight and impact loading due to landing.
- o. For live loads on pedestrian bridges see AASHTO LRFD *Guide Specifications for the Design of Pedestrian Bridges*.
- p. All attics with mechanical units shall be designed for a mechanical equipment room loading.

This page intentionally left blank.

CANCELLED

**APPENDIX E SITE-SPECIFIC STRUCTURAL LOADING DATA – UNITED STATES,
ITS TERRITORIES AND POSSESSIONS**

E-1 WIND LOADING DATA TABLE.

Site-specific structural wind loading data for DoD locations within the United States, its territories and possessions is provided in Table E-1.

E-2 SNOW LOADING AND FROST PENETRATION DATA TABLE.

Site-specific structural snow loading and frost penetration data for DoD locations within the United States, its territories and possessions is provided in Table E-2.

E-3 EARTHQUAKE LOADING DATA TABLE.

Site-specific earthquake loading data for DoD locations within the United States, its territories and possessions is provided in Table E-3.

TABLE E-1 - WIND LOADING DATA – UNITED STATES, ITS TERRITORIES AND POSSESSIONS

Table E-1

State	Base / City	Wind Speed (mph)				Wind Speed (km/h)			
		Risk Category				Risk Category			
		I	II	III-IV	V	I	II	III-IV	V
Alabama	Anniston Army Depot	105	115	120	146	169	185	193	235
	Birmingham	105	115	120	146	169	185	193	235
	Fort McClellan	105	115	120	146	169	185	193	235
	Fort Rucker	112	120	128	156	180	193	206	250
	Maxwell-Gunther AFB / Montgomery	105	115	120	146	169	185	193	235
	Mobile	142	155	165	201	229	249	266	323
	Redstone Arsenal / Huntsville	105	115	120	146	169	185	193	235
Alaska	Clear AS	105	110	115	140	169	177	185	225
	Eielson AFB	105	110	115	140	169	177	185	225
	\1\ Note 2 /1/	120	132	135	164	193	212	217	264
	Fort Greely	105	110	115	140	169	177	185	225
	\1\ Note 2 /1/	135	145	150	182	217	233	241	294
	Fort Wainwright	105	110	115	140	169	177	185	225
	Galena AFB	114	122	129	157	183	196	208	252

Table E-1

State	Base / City	Wind Speed (mph)				Wind Speed (km/h)			
		Risk Category				Risk Category			
		I	II	III-IV	V	I	II	III-IV	V
Alaska	Juneau	121	133	138	168	195	214	222	270
	Ketchikan	126	138	144	175	203	222	232	282
	Kodiak	150	160	165	201	241	257	266	323
	Sitka	139	148	150	182	224	238	241	294
	Valdez	128	138	146	178	206	222	235	286
Arizona	Davis-Monthan AFB / Tucson AFB	105	115	120	146	169	185	193	235
	Fort Huachuca	105	115	120	146	169	185	193	235
	Luke Air Force Base	105	115	120	146	169	185	193	235
	Phoenix	105	115	120	146	169	185	193	235
	MCAS Yuma	105	115	120	146	169	185	193	235
	Yuma Proving Ground	105	115	120	146	169	185	193	235
Arkansas	Little Rock AFB	105	115	120	146	169	185	193	235
	Pine Bluff Arsenal	105	115	120	146	169	185	193	235
California	Alameda	100	110	115	140	161	177	185	225
	MCLB Barstow	100	110	115	140	161	177	185	225
	Beale AFB	100	110	115	140	161	177	185	225
	MCMWTC Bridgeport	100	110	115	140	161	177	185	225
	MCB Camp Pendleton	100	110	115	140	161	177	185	225
	NWS China Lake	118 SWR	126 SWR	135 SWR	164 SWR	190 SWR	203 SWR	218 SWR	265 SWR
	NSWC Corona	100 SWR	110 SWR	115 SWR	140 SWR	161 SWR	177 SWR	185 SWR	225 SWR
	NRTF Dixon	100	110	115	140	161	177	185	225
	Edwards AFB	100 SWR	110 SWR	115 SWR	140 SWR	161 SWR	177 SWR	185 SWR	225 SWR
	El Centro NAF	100	110	115	140	161	177	185	225
	Fort Hunter Liggett	100	110	115	140	161	177	185	225
	Fort Irwin	100	110	115	140	161	177	185	225
	Fresno ANG	100	110	115	140	161	177	185	225

Table E-1

State	Base / City	Wind Speed (mph)				Wind Speed (km/h)			
		Risk Category				Risk Category			
		I	II	III-IV	V	I	II	III-IV	V
California	NAS Lemoore	100	110	115	140	161	177	185	225
	Los Angeles AFB / El Segundo	100 SWR	110 SWR	115 SWR	140 SWR	161 SWR	177 SWR	185 SWR	225 SWR
	Los Angeles	100 SWR	110 SWR	115 SWR	140 SWR	161 SWR	177 SWR	185 SWR	225 SWR
	March ARB	100 SWR	110 SWR	115 SWR	140 SWR	161 SWR	177 SWR	185 SWR	225 SWR
	McClellan AFB / Sacramento	100	110	115	140	161	177	185	225
	NWC Mohave Range	100	110	115	140	161	177	185	225
	Presidio of Monterey	100	110	115	140	161	177	185	225
	Point Mugu / Port Hueneme	100	110	115	140	161	177	185	225
	San Diego Region NAS North Island NAB Coronado MCRD MCAS Miramar Naval Medical Ctr San Diego NS Point Loma	100	110	115	140	161	177	185	225
	Moffett Field - Onizuka / Sunnyvale	100	110	115	140	161	177	185	225
	San Clemente Island Naval Reservation	100	110	115	140	161	177	185	225
	San Nicolas Island	100	110	115	140	161	177	185	225
	Seal Beach NWS	100	110	115	140	161	177	185	225

Table E-1

State	Base / City	Wind Speed (mph)				Wind Speed (km/h)			
		Risk Category				Risk Category			
		I	II	III-IV	V	I	II	III-IV	V
California	Seal Beach NWS – Concord Detachment	100	110	115	140	161	177	185	225
	Sierra Army Depot / Herlong	100	110	115	140	161	177	185	225
	Stockton / San Joaquin	100	110	115	140	161	177	185	225
	Travis AFB	100	110	115	140	161	177	185	225
	MCB Twentynine Palms	100	110	115	140	161	177	185	225
	Vandenberg AFB	100	110	115	140	161	177	185	225
Colorado	Buckley AFB / Aurora	105 SWR	115 SWR	120 SWR	146 SWR	169 SWR	185 SWR	193 SWR	235 SWR
	Denver	105 SWR	115 SWR	120 SWR	146 SWR	169 SWR	185 SWR	193 SWR	235 SWR
	Fort Carson	105 SWR	115 SWR	120 SWR	146 SWR	169 SWR	185 SWR	193 SWR	235 SWR
	Cheyenne Mountain AS / NORAD	105 SWR	115 SWR	120 SWR	146 SWR	169 SWR	185 SWR	193 SWR	235 SWR
	Peterson AFB / Colorado Springs	105	115	120	146	169	185	193	235
	Schriever AFB	105	115	120	146	169	185	193	235
	USAF Academy	105 SWR	115 SWR	120 SWR	146 SWR	169 SWR	185 SWR	193 SWR	235 SWR
Connecticut	NSB New London / Groton	124	135	145	176	200	217	233	284
Delaware	Dover AFB	105	115	120	146	169	185	193	235

Table E-1

State	Base / City	Wind Speed (mph)				Wind Speed (km/h)			
		Risk Category				Risk Category			
		I	II	III-IV	V	I	II	III-IV	V
District of Columbia	Washington Region	105	115	120	146	169	185	193	235
	Bolling AFB								
	Anacostia NS								
	Fort McNair								
	Marine Barracks								
	NRL								
	Washington NDW / Anacostia								
	Pentagon Walter Reed								
Florida	Avon Park AS	129	139	148	180	208	224	238	290
	Cape Canaveral AFS	134	146	156	190	216	235	251	305
	Eglin AFB	131	141	152	185	211	227	245	297
	Homestead	158	170	181	220	254	274	291	354
	Hurlburt Field	134	145	156	190	216	233	251	305
	NAS Jacksonville / MCSF Blount Island / Jacksonville	116	126	136	165	187	203	219	266
	NAS Key West	170	180	200	243	274	290	322	391
	MacDill AFB	133	143	151	184	214	230	243	296
	NAS Mayport	119	129	140	170	192	208	225	274
	HQ Southcom / Miami	155	167	178	216	249	269	286	348
	Orlando	127	137	146	178	204	220	235	286
	NAS Panama City	125	135	145	176	201	217	233	284
	Patrick AFB	138	150	160	195	222	241	257	313
	NAS Pensacola	142	153	165	201	229	246	266	323
	Tampa	131	140	150	182	211	225	241	294
	Tyndall AFB	122	133	144	175	196	214	232	282
	NAS Whiting Field / Milton	134	146	156	190	216	235	251	305
Georgia	MCLB Albany	105	115	120	146	169	185	193	235

Table E-1

State	Base / City	Wind Speed (mph)				Wind Speed (km/h)			
		Risk Category				Risk Category			
		I	II	III-IV	V	I	II	III-IV	V
Georgia	Athens NCSC	105	115	120	146	169	185	193	235
	Dobbins AFB / Atlanta NAS	105	115	120	146	169	185	193	235
	Fort Benning	105	115	120	146	169	185	193	235
	Fort Gordon	105	115	120	146	169	185	193	235
	Fort McPherson / Fort Gillem	105	115	120	146	169	185	193	235
	Fort Stewart	115	126	137	167	185	203	220	268
	Hunter Army Airfield / Savannah	121	134	147	179	195	216	237	288
	NSB Kings Bay	115	124	136	165	185	200	219	266
	Moody AFB	105	115	120	146	169	185	193	235
	Robins AFB	105	115	120	146	169	185	193	235
Hawaii	PMRF Barking Sands, Kauai	115 SWR	130 SWR	145 SWR	176 SWR	185 SWR	209 SWR	233 SWR	283 SWR
	MCBH Kaneohe Bay	115 SWR	130 SWR	145 SWR	176 SWR	185 SWR	209 SWR	233 SWR	283 SWR
	Pohakuloa Training Area	115 SWR	130 SWR	145 SWR	176 SWR	185 SWR	209 SWR	233 SWR	283 SWR
	Pearl Harbor Region: Camp H.M. Smith Fort Shafter Hickam AFB Pearl Harbor Tripler AMC	115 SWR	130 SWR	145 SWR	176 SWR	185 SWR	209 SWR	233 SWR	283 SWR
	Wahiawa Region: Lualualei Wahiawa Naval Reservation Wheeler AFB Schofield Barracks	115 SWR	130 SWR	145 SWR	176 SWR	185 SWR	209 SWR	233 SWR	283 SWR
Idaho	ARD Bayview	105	115	120	146	169	185	193	235

Table E-1

State	Base / City	Wind Speed (mph)				Wind Speed (km/h)			
		Risk Category				Risk Category			
		I	II	III-IV	V	I	II	III-IV	V
Idaho	Boise ANG	105	115	120	146	169	185	193	235
	Mountain Home AFB	105	115	120	146	169	185	193	235
Illinois	Fort Sheridan / Chicago	105	115	120	146	169	185	193	235
	Great Lakes	105	115	120	146	169	185	193	235
	Rock Island Arsenal	105	115	120	146	169	185	193	235
	Scott AFB	105	115	120	146	169	185	193	235
	Springfield	105	115	120	146	169	185	193	235
Indiana	Crane NWSC	105	115	120	146	169	185	193	235
	Grissom ARB	105	115	120	146	169	185	193	235
	Fort Benjamin Harrison / Indianapolis	105	115	120	146	169	185	193	235
Iowa	Des Moines	105	115	120	146	169	185	193	235
Kansas	Fort Leavenworth	105	115	120	146	169	185	193	235
	Fort Riley	105	115	120	146	169	185	193	235
	McConnell AFB	105	115	120	146	169	185	193	235
Kentucky	Fort Campbell	105	115	120	146	169	185	193	235
	Fort Knox	105	115	120	146	169	185	193	235
	Louisville	105	115	120	146	169	185	193	235
	Richmond	105	115	120	146	169	185	193	235
Louisiana	Barksdale AFB	105	115	120	146	169	185	193	235
	Fort Polk / Leesville	105	115	122	148	169	185	196	239
	NAS JRB New Orleans / Belle Chasse	137	148	158	192	220	238	254	309
Maine	NAS Brunswick	105	116	124	151	169	187	200	243
	NRTF Cutler	105	115	121	147	169	185	195	237
	PNSY Kittery	111	121	132	161	179	195	212	258
	Winter Harbor NSGA	106	116	125	152	171	187	201	245

Table E-1

State	Base / City	Wind Speed (mph)				Wind Speed (km/h)			
		Risk Category				Risk Category			
		I	II	III-IV	V	I	II	III-IV	V
Maryland	Aberdeen Proving Ground	105	115	120	146	169	185	193	235
	Adelphi	105	115	120	146	169	185	193	235
	Andrews AFB	105	115	120	146	169	185	193	235
	Carderock NSWC / Bethesda	105	115	120	146	169	185	193	235
	Bloods Island	105	115	120	146	169	185	193	235
	Edgewood Arsenal	105	115	120	146	169	185	193	235
	Fort Detrick / Fredrick	105	115	120	146	169	185	193	235
	Fort Meade	105	115	120	146	169	185	193	235
	Indian Head NSWC	105	115	120	146	169	185	193	235
	Martin State ANG	105	115	120	146	169	185	193	235
	NS Pax River , Webster Field / St. Inigoes	105	115	120	146	169	185	193	235
	U.S. Naval Academy / Annapolis	105	115	120	146	169	185	193	235
Massachusetts	Fort Devens / Ayer	111	122	132	161	179	196	212	258
	Hanscom AFB	115	125	136	165	185	201	219	266
	Natick	117	127	138	168	188	204	222	270
	Otis AGB / Falmouth	131	140	151	184	211	225	243	296
	Westover ARB	108	119	128	156	174	192	206	250
Michigan	Battle Creek	105	115	120	146	169	185	193	235
	Detroit Arsenal / Warren	105	115	120	146	169	185	193	235
	Selfridge ANG Base	105	115	120	146	169	185	193	235
Minnesota	Minneapolis – St Paul	105	115	120	146	169	185	193	235

Table E-1

State	Base / City	Wind Speed (mph)				Wind Speed (km/h)			
		Risk Category				Risk Category			
		I	II	III-IV	V	I	II	III-IV	V
Mississippi	Stennis / Bay St. Louis	144	158	171	208	232	254	275	335
	Columbus AFB	105	115	120	146	169	185	193	235
	Gulfport	147	160	174	212	237	257	280	341
	Jackson	105	115	120	146	169	185	193	235
	Keesler AFB	148	160	176	214	238	257	283	344
	NAS Meridian	106	116	122	148	171	187	196	239
	Pascagoula NS	149	160	177	215	240	257	285	346
	Vicksburg	105	115	120	146	169	185	193	235
	Missouri	Fort Leonard Wood	105	115	120	146	169	185	193
Kansas City		105	115	120	146	169	185	193	235
Overland		105	115	120	146	169	185	193	235
St. Louis		105	115	120	146	169	185	193	235
Whiteman AFB		105	115	120	146	169	185	193	235
Montana	Great Falls ANG	105 SWR	115 SWR	120 SWR	146 SWR	169 SWR	185 SWR	193 SWR	235 SWR
	Malmstrom AFB	105 SWR	115 SWR	120 SWR	146 SWR	169 SWR	185 SWR	193 SWR	235 SWR
Nebraska	Offutt AFB	105	115	120	146	169	185	193	235
	Lincoln	105	115	120	146	169	185	193	235
Nevada	NAS Fallon	105	115	120	146	169	185	193	235
	Indian Springs AFS	105	115	120	146	169	185	193	235
	Nellis AFB	105	115	120	146	169	185	193	235
	Nellis AF Range	105	115	120	146	169	185	193	235
New Jersey	NWS Earle / Colts Neck	107	117	126	153	172	188	203	247
	Fort Dix / Trenton	105	115	122	148	169	185	196	239
	Fort Monmouth	109	119	128	156	175	192	206	250
	Lakehurst	108	118	127	154	174	190	204	249
	McGuire AFB	105	115	120	146	169	185	193	235

Table E-1

State	Base / City	Wind Speed (mph)				Wind Speed (km/h)			
		Risk Category				Risk Category			
		I	II	III-IV	V	I	II	III-IV	V
New Jersey	Picatinny Arsenal	105	115	120	146	169	185	193	235
New Mexico	Albuquerque	105	115	120	146	169	185	193	235
	Cannon AFB	105	115	120	146	169	185	193	235
	Holloman AFB	105	115	120	146	169	185	193	235
	Kirtland AFB	105	115	120	146	169	185	193	235
	White Sands	105	115	120	146	169	185	193	235
New York	Buffalo	105	115	120	146	169	185	193	235
	Fort Drum	105	115	120	146	169	185	193	235
	Fort Hamilton / Brooklyn	106	116	123	150	171	187	198	241
	Griffis AFB / Rome	105	115	120	146	169	185	193	235
	NIAGARA FALLS IAP	105	115	120	146	169	185	193	235
	NSU Saratoga Springs	105	115	120	146	169	185	193	235
	Stewart ANG / Newburgh	105	115	120	146	169	185	193	235
	Syracuse	105	115	120	146	169	185	193	235
	West Point	105 SWR	115 SWR	120 SWR	146 SWR	169 SWR	185 SWR	193 SWR	235 SWR
	Watervliet Arsenal / Albany	105	115	120	146	169	185	193	235
North Carolina	MCAS Cherry Point	128	138	147	179	206	222	237	288
	Fort Bragg	109	119	128	156	175	192	206	250
	Harvey Point	114	122	131	159	183	196	211	256
	Jacksonville Region MCB Camp Lejeune MCAS New River	130	140	148	180	209	225	238	290
	Pope AFB	109	119	127	154	175	192	204	249
	Raleigh	105	115	120	146	169	185	193	235

Table E-1

State	Base / City	Wind Speed (mph)				Wind Speed (km/h)			
		Risk Category				Risk Category			
		I	II	III-IV	V	I	II	III-IV	V
North Carolina	Seymour Johnson AFB	113	122	131	159	182	196	211	256
North Dakota	Grand Forks AFB	105	115	120	146	169	185	193	235
	NRTF La Moure	105	115	120	146	169	185	193	235
	Minot AFB	105	115	120	146	169	185	193	235
Ohio	Cleveland	105	115	120	146	169	185	193	235
	DSC Whitehall / Columbus	105	115	120	146	169	185	193	235
	Wright-Patterson AFB	105	115	120	146	169	185	193	235
	Youngstown ARS / Vienna	105	115	120	146	169	185	193	235
Oklahoma	Altus AFB	105	115	120	146	169	185	193	235
	Fort Sill	105	115	120	146	169	185	193	235
	McAlester Army Ammunition Plant	105	115	120	146	169	185	193	235
	Tinker AFB / Oklahoma City	105	115	120	146	169	185	193	235
	Tulsa	105	115	120	146	169	185	193	235
	Vance AFB	105	115	120	146	169	185	193	235
Oregon	Portland	100 SWR	110 SWR	115 SWR	140 SWR	161 SWR	177 SWR	185 SWR	225 SWR
Pennsylvania	ARS Coraopolis / Pittsburgh	105	115	120	146	169	185	193	235
	Carlisle Barracks	105	115	120	146	169	185	193	235
	Fort Indiantown Gap / Annville	105	115	120	146	169	185	193	235
	Letterkenny / Chambersburg	105	115	120	146	169	185	193	235
	Mechanicsburg	105	115	120	146	169	185	193	235
	Philadelphia	105	115	120	146	169	185	193	235
	New Cumberland / Defense Depot Susquehanna	105	115	120	146	169	185	193	235

Table E-1

State	Base / City	Wind Speed (mph)				Wind Speed (km/h)			
		Risk Category				Risk Category			
		I	II	III-IV	V	I	II	III-IV	V
Pennsylvania	Tobyhanna Army Depot	105	115	120	146	169	185	193	235
	Willow Grove ARS / NAS	105	115	120	146	169	185	193	235
Rhode Island	NS Newport	129	140	150	182	208	225	241	294
South Carolina	MCAS Beaufort	125	139	152	185	201	224	245	297
	Charleston Region: Charleston AFB NWS Charleston	130	144	154	187	209	232	248	301
	Columbia Region: McEntire Fort Jackson Shaw AFB	110	120	131	159	177	193	211	256
	MCRD Parris Island	126	140	152	185	203	225	245	297
South Dakota	Ellsworth AFB	105	115	120	146	169	185	193	235
Tennessee	Arnold AFB	105	115	120	146	169	185	193	235
	NSWC LCC / Memphis	105	115	120	146	169	185	193	235
	NSA Mid-South / Millington	105	115	120	146	169	185	193	235
	Nashville	105	115	120	146	169	185	193	235
Texas	NAS JRB, Carswell / Fort Worth	105	115	120	146	169	185	193	235
	NAS Corpus Christi	137	149	158	192	220	240	254	309
	Dallas / Irving	105	115	120	146	169	185	193	235
	Dyess AFB	105	115	120	146	169	185	193	235
	Ellington ANG / Houston	132	141	150	182	212	227	241	294
	Fort Bliss / El Paso	105	115	120	146	169	185	193	235

Table E-1

State	Base / City	Wind Speed (mph)				Wind Speed (km/h)			
		Risk Category				Risk Category			
		I	II	III-IV	V	I	II	III-IV	V
Texas	Fort Hood / Killeen	105	115	120	146	169	185	193	235
	Goodfellow AFB	105	115	120	146	169	185	193	235
	NS Ingleside	136	146	155	188	219	235	249	303
	NAS Kingsville	129	137	146	178	208	220	235	286
	Laughlin AFB	105	115	120	146	169	185	193	235
	Red River Army Depot / Texarkana	105	115	120	146	169	185	193	235
	San Antonio Region Brooks AFB Fort Sam Houston Kelly AFB Lackland AFB Randolph AFB	105	115	120	146	169	185	193	235
	Sheppard AFB	105	115	120	146	169	185	193	235
Utah	Dugway Proving Ground	105	115	120	146	169	185	193	235
	Hill AFB	105	115	120	146	169	185	193	235
	Salt Lake City	105	115	120	146	169	185	193	235
	Tooele Army Depot	105	115	120	146	169	185	193	235
Virginia	Dahlgren	105	115	120	146	169	185	193	235
	Dam Neck / Virginia Beach Ocean front	114	123	133	162	183	198	214	260
	Fort A. P. Hill	105	115	120	146	169	185	193	235
	Fort Belvoir	105	115	120	146	169	185	193	235
	Fort Eustis	105	115	120	146	169	185	193	235
	Fort Lee	105	115	120	146	169	185	193	235
	Fort Monroe	107	116	123	150	172	187	198	241
	Fort Myer	105	115	120	146	169	185	193	235
	Fort Story	113	121	131	159	182	195	211	256

Table E-1

State	Base / City	Wind Speed (mph)				Wind Speed (km/h)			
		Risk Category				Risk Category			
		I	II	III-IV	V	I	II	III-IV	V
Virginia	Henderson Hall / Arlington	105	115	120	146	169	185	193	235
	Langley AFB / Hampton	106	115	121	147	171	185	195	237
	NAB Little Creek	110	118	127	154	177	190	204	249
	Norfolk Region: Camp Elmore Craney Island Depot Norfolk Naval Base	108	117	124	151	174	188	200	243
	Norfolk Shipyard – Naval Hospital / Portsmouth	108	117	125	152	174	188	201	245
	NSA Northwest / Chesapeake	109	118	127	154	175	190	204	249
	NAS Oceana / Virginia Beach	113	121	131	159	182	195	211	256
	MCB Quantico	105	115	120	146	169	185	193	235
	Radford AAP	105	115	120	146	169	185	193	235
	Defense Supply Ctr / Richmond	105	115	120	146	169	185	193	235
	Wallops Island	116	125	134	163	187	201	216	262
	Yorktown Region: Camp Perry Cheatham Annex Yorktown NWS	105	115	120	146	169	185	193	235
Washington	NS Everett	100	110	115	140	161	177	185	225
	Fairchild AFB	100	110	115	140	161	177	185	225
	Fort Lewis / Tacoma	100	110	115	140	161	177	185	225
	Indian Island SWC	100	110	115	140	161	177	185	225
	NRS Jim Creek	100	110	115	140	161	177	185	225
Washington	Keyport / Bangor Engin. Sta	100	110	115	140	161	177	185	225

Table E-1

State	Base / City	Wind Speed (mph)				Wind Speed (km/h)			
		Risk Category				Risk Category			
		I	II	III-IV	V	I	II	III-IV	V
	Annex								
	McChord AFB	100	110	115	140	161	177	185	225
	Puget Sound Region: Bangor NSB Bremerton NS Puget Sound NSY	100	110	115	140	161	177	185	225
	NAS Whidbey Island / Oak Harbor	100	110	115	140	161	177	185	225
	Seattle	100	110	115	140	161	177	185	225
West Virginia	Allegheny Ballistics Lab	105	115	120	146	169	185	193	235
	Beckley	105	115	120	146	169	185	193	235
	Huntington	105	115	120	146	169	185	193	235
	Sugar Grove NRS	105	115	120	146	169	185	193	235
Wisconsin	Fort McCoy	105	115	120	146	169	185	193	235
	General Mitchell AFRC / Milwaukee	105	115	120	146	169	185	193	235
	Madison	105	115	120	146	169	185	193	235
Wyoming	F. E. Warren AFB	105	115	120	146	169	185	193	235
American Samoa	Pago Pago / Tutuila Island	150	160	170	207	241	257	274	333
Mariana Islands	Guam	180	195	210	255	290	314	338	411
	Saipan / Tinian	177	190	203	247	285	306	327	397
Puerto Rico	NRTF Aguada	140	151	160	195	225	243	257	313
	Fort Buchanan	150	159	168	204	241	256	270	329
	Ramey AFB	140	150	161	196	225	241	259	315
	NS Roosevelt Roads	156	169	178	216	251	272	286	348
Puerto Rico	Sebana Seca NRS	149	158	166	202	240	254	267	325

**Notes to TABLE E-1, “WIND LOADING DATA – UNITED STATES,
ITS TERRITORIES AND POSSESSIONS”**

SWR - Special wind regions where unusual geographic conditions require consideration for potential unusual wind conditions. The wind speeds shown are minimum values. The potential for higher wind speeds due to unusual geographic conditions should also be considered.

- 1) Wind speeds for NWS China Lake have been increased based on local information.

\1\

- 2) Wind speeds for Elmendorf AFB and Fort Richardson, Alaska are based on Municipality of Anchorage maps entitled, “Three Second Gust Wind Zones”.

/1/

CANCELLED

TABLE E-2 - SNOW LOADING AND FROST PENETRATION DATA – UNITED STATES, ITS TERRITORIES AND POSSESSIONS

Table E-2

State	Base / City	Ground Snow (psf)	Frost Penetration (b) (in)	Ground Snow (kPa)	Frost Penetration (b) (mm)
Alabama	Anniston Army Depot	5	6	0.24	152
	Birmingham	5	6	0.24	152
	Fort McClellan	5	6	0.24	152
	Fort Rucker	0	0	0	0
	Maxwell-Gunther AFB / Montgomery	5	4	0.24	102
	Mobile	0	0	0	0
	Redstone Arsenal / Huntsville	10	9	0.48	229
Alaska	Clear AS	60		2.87	
	Eielson AFB	70	permafrost	2.87	permafrost
	Elmendorf AFB	50	129	2.4	3277
	Fort Greely	60	Permafrost	2.87	permafrost
	Fort Richardson	50	129	2.4	3277
	Fort Wainwright	60	permafrost	2.87	permafrost
	Galena AFB	60		2.87	
	Juneau	60	86	2.87	2184
	Ketchikan			0	
	Kodiak	30	86	1.44	2184
Arizona	Davis-Monthan AFB / Tucson AFB	5	0	0	0
	Fort Huachuca	10	0	0.48	0
	Luke Air Force Base	0	5	0	127
	Phoenix	0	0	0	0
	MCAS Yuma	0	0	0	0
	Yuma Proving Ground	0	0	0	0
Arkansas	Little Rock AFB	10	14	0.48	356

Table E-2

State	Base / City	Ground Snow (psf)	Frost Penetration (b) (in)	Ground Snow (kPa)	Frost Penetration (b) (mm)
Arkansas	Pine Bluff Arsenal	10	9	0.48	229
California	Alameda	0		0	
	MCLB Barstow	5	18	0	457
	Beale AFB	0		0	
	MCMWTC Bridgeport	150	36	7.19	914
	MCB Camp Pendleton	0	4	0	102
	NWS China Lake	5	22	0	559
	NSWC Corona	0	0	0	0
	NRTF Dixon	0	0	0	0
	Edwards AFB	5	22	0	559
	EI Centro NAF	0	0	0	0
	Fort Hunter Ligget	0	0	0	0
	Fort Irwin	0	22	0	559
	Fresno ANG	0	0	0	0
	NAS Lemoore	0	0	0	0
	Los Angeles AFB / El Segundo	0	0	0	0
	Los Angeles	0	0	0	0
	March ARB	0	0	0	0
	McClellan AFB / Sacramento	0	5	0	127
	NWC Mohave Range	0	22	0	559
	Presidio of Monterey	0	4	0	102
	Point Mugu / Port Hueneme	0	0	0	0
	San Diego Region NAS North Island NAB Coronado MCRD MCAS Miramar Naval Medical Ctr San Diego NS Point Loma	0	0	0	0

Table E-2

State	Base / City	Ground Snow (psf)	Frost Penetration (b) (in)	Ground Snow (kPa)	Frost Penetration (b) (mm)
California	Moffett Field - Onizuka /	0	0	0	0
	Sunnyvale				
	San Clemente Island Naval Reservation	0	0	0	0
	San Nicolas Island	0	0	0	0
	Seal Beach NWS	0	0	0	0
	Seal Beach NWS – Concord Detachment	0	0	0	0
	Sierra Army Depot / Herlong	15	54	0.72	1372
	Stockton / San Joaquin	0	4	0	102
	Travis AFB	0	0	0	0
	MCB Twentynine Palms	5	5	0	127
	Vandenberg AFB	0	0	0	0
Colorado	Buckley AFB / Aurora	20	52	0.96	1321
	Denver	20	52	0.96	1321
	Fort Carson	15	38	0.72	965
	Cheyenne Mountain AS / NORAD	15	38	0.72	965
	Peterson AFB / Colorado Springs	30	38	1.44	965
	Schriever AFB	30	38	1.44	
	USAF Academy	30	38	1.44	965
Connecticut	NSB New London / Groton	30	38	1.44	965
Delaware	Dover AFB	25	22	1.2	559

Table E-2

State	Base / City	Ground Snow (psf)	Frost Penetration (b) (in)	Ground Snow (kPa)	Frost Penetration (b) (mm)
District of Columbia	Washington Region	25	26	1.2	660
	Bolling AFB				
	Anacostia NS				
	Fort McNair				
	Marine Barracks				
	NRL Washington				
	NDW / Anacostia				
	Pentagon				
Walter Reed					
Florida	Avon Park AS	0	0	0	0
	Cape Canaveral AFS	0	0	0	0
	Eglin AFB	0	0	0	0
	Homestead	0	0	0	0
	Hurlburt Field	0		0	
	NAS Jacksonville / MCSF Blount Island / Jacksonville	0	0	0	0
	NAS Key West	0	0	0	0
	MacDill AFB	0	0	0	0
	NAS Mayport	0	0	0	0
	HQ Southcom / Miami	0	0	0	0
	Orlando	0	0	0	0
	NAS Panama City	0	0	0	0
	Patrick AFB	0	0	0	0
	NAS Pensacola	0	0	0	0
	Tampa	0	0	0	0
	Tyndall AFB	0	0	0	0
	NAS Whiting Field / Milton	0	0	0	0
Georgia	MCLB Albany	0	0	0	0
	Athens NCSC	5		0.24	
	Dobbins AFB / Atlanta NAS	5		0.24	
	Fort Benning	5	0	0.24	0

Table E-2

State	Base / City	Ground Snow (psf)	Frost Penetration (b) (in)	Ground Snow (kPa)	Frost Penetration (b) (mm)
Georgia	Fort Gordon	10	0	0.48	0
	Fort McPherson / Fort Gillem	5		0.24	
	Fort Stewart	0	0	0	0
	Hunter Army Airfield / Savannah	0	0	0	0
	NSB Kings Bay	0	0	0	0
	Moody AFB	0	0	0	0
	Robins AFB	5	0	0.24	0
Hawaii	PMRF Barking Sands, Kauai	0	0	0	0
	MCBH Kaneohe Bay	0	0	0	0
	Pohakuloa Training Area	0	0	0	0
	Pearl Harbor Region: Camp H.M. Smith Fort Shafter Hickam AFB Pearl Harbor Tripler AMC	0	0	0	0
	Wahiawa Region: Lualualei Wahiawa Naval Reservation Wheeler AFB Schofield Barracks	0	0	0	0
Idaho	ARD Bayview	10		0.48	
	Boise ANG	10		0.48	
	Mountain Home AFB	20	64	0.96	1626
Illinois	Fort Sheridan / Chicago	25	59	1.2	1499
	Great Lakes	30	64	1.2	1626
	Rock Island Arsenal	20	64	0.96	1626
	Scott AFB	20	38	0.96	965

Table E-2

State	Base / City	Ground Snow (psf)	Frost Penetration (b) (in)	Ground Snow (kPa)	Frost Penetration (b) (mm)
Illinois	Springfield	20		0.96	
Indiana	Crane NWSC	20	36	0.96	914
	Grissom ARB	20	49	0.96	1245
	Fort Benjamin Harrison / Indianapolis	20	44	0.96	1118
Iowa	Des Moines	25	82	1.2	2083
Kansas	Fort Leavenworth	20	54	0.96	1372
	Fort Riley	20	52	0.96	1321
	McConnell AFB	25	38	1.2	965
Kentucky	Fort Campbell	15	22	0.72	559
	Fort Knox	15	32	0.72	813
	Louisville	15	32	0.72	813
	Richmond	15		0.72	0
Louisiana	Barksdale AFB	5	7	0.24	178
	Fort Polk / Leesville	5	0	0.24	0
	NAS JRB New Orleans / Belle Chasse	0	0	0	0
Maine	NAS Brunswick	60	86	2.4	2184
	NRTF Cutler	50	86	2.4	2184
	PNSY Kittery	50	48	2.4	1220
	Winter Harbor NSGA	50	86	2.4	2184
Maryland	Aberdeen Proving Ground	25	29	1.2	737
	Adelphi	25	24	1.2	610
	Andrews AFB	25	26	1.2	660
	Carderock NSWC / Bethesda	25	20	1.2	508
	Bloods Island	20		0.96	
	Edgewood Arsenal	25	29	1.2	737
	Fort Detrick / Fredrick	30	29	1.44	737
	Fort Meade	25	26	1.2	660
Maryland	Indian Head NSWC	25	22	1.2	559

Table E-2

State	Base / City	Ground Snow (psf)	Frost Penetration (b) (in)	Ground Snow (kPa)	Frost Penetration (b) (mm)
	Martin State ANG	25	29	1.2	737
	NS Pax River , Webster Field / St. Inigoes	20	26	0.96	660
	U.S. Naval Academy / Annapolis	25	26	1.2	660
Massachusetts	Fort Devens / Ayer	50	64	2.4	1626
	Hanscom AFB	50	54	2.4	1372
	Natick	50		2.4	
	Otis AGB / Falmouth	35	38	1.2	965
	Westover ARB	35	64	1.68	1626
Michigan	Battle Creek	30		1.44	
	Detroit Arsenal / Warren	25	61	1.2	1549
	Selfridge ANG Base	25	59	1.2	1499
Minnesota	Minneapolis – St Paul	50	125	2.4	3175
Mississippi	Stennis / Bay St. Louis	0		0	
	Columbus AFB	10	7	0.48	178
	Gulfport	0	0	0	0
	Jackson	5	5	0.24	127
	Keesler AFB	0	0	0	0
	NAS Meridian	5	5	0.24	127
	Pascagoula NS	0	0	0	0
	Vicksburg	5		0.24	
Missouri	Fort Leonard Wood	20	36	0.96	914
	Kansas City	20	49	0.96	1245
	Overland	20		0.96	
	St. Louis	20	38	0.96	965
	Whiteman AFB	20	46	0.96	1168
Montana	Great Falls ANG	20	107	0.96	2718
	Malmstrom AFB	20	107	0.96	2718
Nebraska	Offutt AFB	25	73	1.2	1854

Table E-2

State	Base / City	Ground Snow (psf)	Frost Penetration (b) (in)	Ground Snow (kPa)	Frost Penetration (b) (mm)
	Lincoln	25	64	1.2	1626
Nevada	NAS Fallon	10	23	0.24	584
	Indian Springs AFS	5	7	0.24	178
	Nellis AFB	5	7	0.24	178
	Nellis AF Range	5	7	0.24	178
New Jersey	NWS Earle / Colts Neck	20		0.96	
	Fort Dix / Trenton	25	29	1.2	737
	Fort Monmouth	25	32	0.96	813
	Lakehurst	25	29	1.2	737
	McGuire AFB	25	29	1.2	737
	Picatinny Arsenal	35	52	1.68	1321
New Mexico	Albuquerque	10	18	0.48	457
	Cannon AFB	15	18	0.72	457
	Holloman AFB	5	4	0.24	102
	Kirtland AFB	10	18	0.48	457
	White Sands	5	4	0.24	102
New York	Buffalo	45	59	2.16	1499
	Fort Drum	70	94	3.35	2388
	Fort Hamilton / Brooklyn	25		1.2	
	Griffis AFB / Rome	60	86	2.87	2184
	NIAGARA FALLS IAP	35	59	1.68	1499
	NSU Saratoga Springs	50		2.4	
	Stewart ANG / Newburgh	35	54	1.68	1372
	Syracuse	40	73	1.92	1854
	West Point	35	54	1.44	1372
	Watervliet Arsenal / Albany	40	82	1.92	2083
North Carolina	MCAS Cherry Point	10	0	0.48	0

Table E-2

State	Base / City	Ground Snow (psf)	Frost Penetration (b) (in)	Ground Snow (kPa)	Frost Penetration (b) (mm)
	Fort Bragg	10	0	0.48	0
	Harvey Point	10	0	0.48	0
	Jacksonville Region MCB Camp Lejeune MCAS New River	10	0	0.48	0
	Pope AFB	10	0	0.48	0
	Raleigh	15		0.72	
	Seymour Johnson AFB	10	4	0.48	102
North Dakota	Grand Forks AFB	60	156	2.87	3962
	NRTF La Moure	40		1.92	
	Minot AFB	40	163	1.92	4140
Ohio	Cleveland	20	52	0.96	1321
	DSC Whitehall / Columbus	20	46	0.96	1168
	Wright-Patterson AFB	20	49	0.96	1245
	Youngstown ARS / Vienna	20		0.96	
Oklahoma	Altus AFB	10	14	0.48	356
	Fort Sill	10	14	0.48	356
	McAlester Army Ammunition Plant	10	16	0.48	406
	Tinker AFB / Oklahoma City	10	18	0.48	457
	Tulsa	10	23	0.48	584
	Vance AFB	15	22	0.72	559
Oregon	Portland	10	14	0.48	356
Pennsylvania	ARS Coraopolis / Pittsburg	25	38	1.2	965
	Carlisle Barracks	25	36	1.2	914
	Fort Indiantown Gap / Annville	35	49	1.68	1245

Table E-2

State	Base / City	Ground Snow (psf)	Frost Penetration (b) (in)	Ground Snow (kPa)	Frost Penetration (b) (mm)
Pennsylvania	Letterkenny / Chambersburg	30	36	1.44	914
	Mechanicsburg	25		1.2	
	Philadelphia	25	30	1.2	762
	New Cumberland / Defense Depot Susquehanna	25		1.2	0
	Tobyhanna Army Depot	50	52	2.4	
	Willow Grove ARS / NAS	30		1.44	0
	Rhode Island	NS Newport	30	35	1.44
South Carolina	MCAS Beaufort	5	0	0.24	0
	Charleston Region: Charleston AFB NWS Charleston	5	0	0.24	0
	Columbia Region: McEntire Fort Jackson Shaw AFB	10	0	0.48	0
	MCRD Parris Island	0	0	0	0
South Dakota	Ellsworth AFB	20	86	0.96	2184
Tennessee	Arnold AFB	10		0.48	
	NSWC LCC / Memphis	10	0	0.48	0
	NSA Mid-South / Millington	10		0.48	
	Nashville	10	22	0.48	559
	Texas	NAS JRB, Carswell / Fort Worth	5	7	0.24
	NAS Corpus Christi	0	0	0	0
	Dallas / Irving	5	7	0.24	178
	Dyess AFB	5	7	0.24	178
	Ellington ANG / Houston	0	0	0	0

Table E-2

State	Base / City	Ground Snow (psf)	Frost Penetration (b) (in)	Ground Snow (kPa)	Frost Penetration (b) (mm)
	Fort Bliss / El Paso	10	0	0.24	0
	Fort Hood / Killeen	5	6	0.24	152
	Goodfellow AFB	5	5	0.24	127
	NS Ingleside	0	0	0	0
	NAS Kingsville	0	0	0	0
	Laughlin AFB	0	0	0	0
	Red River Army Depot / Texarkana	5	8	0.24	203
	San Antonio Region Brooks AFB Fort Sam Houston Kelly AFB Lackland AFB Randolph AFB	5	0	0.24	0
	Sheppard AFB	5	11	0.24	279
Utah	Dugway Proving Ground	10	54	0.48	1372
	Hill AFB	47	73	2.26	1854
	Salt Lake City	15	59	0.72	1499
	Tooele Army Depot	25	52	1.2	1321
Virginia	Dahlgren	25	22	1.2	559
	Dam Neck / Virginia Beach Ocean front	10	5	0.48	127
	Fort A. P. Hill	25		1.2	
	Fort Belvoir	25	26	1.2	660
	Fort Eustis	15	9	0.72	229
	Fort Lee	20	14	0.96	356
	Fort Monroe	10	9	0.48	229
	Fort Myer	25	26	1.2	660
	Fort Story	10	9	0.48	229
	Henderson Hall / Arlington	25	26	1.2	660
	Langley AFB / Hampton	10	9	0.48	229
	NAB Little Creek	10	9	0.48	229

Table E-2

State	Base / City	Ground Snow (psf)	Frost Penetration (b) (in)	Ground Snow (kPa)	Frost Penetration (b) (mm)
Virginia	Norfolk Region: Camp Elmore Craney Island Depot Norfolk Naval Base	10	9	0.48	229
	Norfolk Shipyard – Naval Hospital / Portsmouth	10	9	0.48	229
	NSA Northwest / Chesapeake	10	9	0.48	229
	NAS Oceana / Virginia Beach	10	9	0.48	229
	MCB Quantico	25	22	1.2	559
	Radford AAP	25	22	1.2	559
	Defense Supply Ctr / Richmond	20	18	0.96	457
	Wallops Island	20		0.96	
Yorktown Region:	Camp Perry Cheatham Annex Yorktown NWS	15	9	0.72	229
	Washington	NS Everett	15 (a)		0.72(a)
	Fairchild AFB	42	64	2.01	1626
	Fort Lewis / Tacoma	15 (a)	9	0.72(a)	229
	Indian Island SWC	15 (a)		0.72(a)	
	NRS Jim Creek	15 (a)		0.72(a)	
	Keyport / Bangor Engin. Sta Annex	15 (a)	9	0.72(a)	229
	McChord AFB	15	9	0.72	229
	Puget Sound Region:	15 (a)	9	0.72(a)	229
	Bangor NSB				
	Bremerton NS				
	Puget Sound NSY				
	NAS Whidbey Island / Oak Harbor	15 (a)		0.72(a)	

Table E-2

State	Base / City	Ground Snow (psf)	Frost Penetration (b) (in)	Ground Snow (kPa)	Frost Penetration (b) (mm)
Washington	Seattle	20	9	0.72	229
West Virginia	Allegheny Ballistics Lab	CS		CS	
	Beckley	30		1.44	
	Huntington	20	22	0.96	559
	Sugar Grove NRS	30	38	1.44	965
Wisconsin	Fort McCoy	40	114	1.92	2896
	General Mitchell AFRC / Milwaukee	30	75	1.44	1905
	Madison	35	86	1.44	2184
Wyoming	F. E. Warren AFB	20	59	0.96	1499
American Samoa	Pago Pago / Tutuila Island	0	0	0	0
Mariana Islands	Guam	0	0	0	0
	Saipan / Tinian	0	0	0	0
Puerto Rico	All	0	0	0	0

Notes to TABLE E-2, “SNOW LOADING AND FROST PENETRATION DATA – UNITED STATES, ITS TERRITORIES AND POSSESSIONS”

(a) – Ground snow load to be used for Navy facilities at identified locations in Washington State equals 25 psf (1.20 kPa).

(b) – See best practice B-2.3 for footing depths considering frost.

CS – Site specific case studies are required to establish ground snow loads.

TABLE E-3 - EARTHQUAKE LOADING DATA – UNITED STATES, ITS TERRITORIES AND POSSESSIONS

Table E-3

		Seismic Data (Site Class B)								
State	Base / City	PGA (%g)	S _s (%g)	S ₁ (%g)	S _{S,5/50} (%g)	S _{1,5/50} (%g)	S _{S,10/50} (%g)	S _{1,10/50} (%g)	S _{S,20/50} (%g)	S _{1,20/50} (%g)
Alabama	Anniston Army Depot	12	24	10	15	7	10	5	6	3
	Birmingham	14	26	10	16	7	10	5	6	2
	Fort McClellan	12	23	10	15	7	10	5	6	3
	Fort Rucker	4	10	6	6	4	4	3	3	2
	Maxwell-Gunther AFB / Montgomery	6	14	8	9	5	6	4	4	2
	Mobile	5	10	6	7	4	4	3	2	1
	Redstone Arsenal / Huntsville	12	25	12	18	9	12	5	6	3
	Alaska	Clear AS	40	98	38	70	27	50	20	34
	Eielson AFB	39	96	37	69	26	49	19	33	13
	Elmendorf AFB	50	150	68	131	59	105	45	79	33
	Fort Greely	28	72	38	50	28	38	21	27	14
	Fort Richardson	50	150	69	130	60	104	46	78	33
	Fort Wainwright	40	99	38	71	27	51	19	34	13
	Galena AFB	19	44	17	29	12	20	8	13	5
	Juneau	21	54	36	38	26	28	20	20	14
	Ketchikan	10	26	23	18	17	14	13	10	9
	Kodiak	64	154	90	142	74	114	57	86	41

Table E-3

		Seismic Data (Site Class B)								
State	Base / City	PGA (%g)	S _s (%g)	S ₁ (%g)	S _{S,5/50} (%g)	S _{1,5/50} (%g)	S _{S,10/50} (%g)	S _{1,10/50} (%g)	S _{S,20/50} (%g)	S _{1,20/50} (%g)
Alaska	Sitka	33	95	60	68	47	54	37	41	28
	Valdez	54	150	77	125	60	96	43	69	29
Arizona	Davis-Monthan AFB / Tucson AFB	11	27	8	18	5	11	3	7	2
	Fort Huachuca	10	24	7	16	5	10	3	6	2
	Luke Air Force Base	7	17	6	11	4	7	3	5	2
	Phoenix	7	17	6	12	4	8	3	5	2
	MCAS Yuma	26	73	27	50	19	38	15	28	11
	Yuma Proving Ground (a)	10	31	16	20	11	16	9	12	7
Arkansas	Little Rock AFB	24	46	18	32	13	17	6	7	2
	Pine Bluff Arsenal	18	35	15	24	10	13	5	6	2
California	Alameda	51	150	60	162	61	127	47	95	34
	MCLB Barstow	59	144	55	104	38	71	27	47	18
	Beale AFB	18	52	25	34	17	27	13	20	10
	MCMWTC Bridgeport	42	110	37	78	26	57	19	39	13
	MCB Camp Pendleton (a)	40	109	42	76	30	58	23	43	17
	NWS China Lake (a)	43	115	39	82	28	62	21	43	15
	NSWC Corona	86	225	85	175	66	127	47	84	32
	NRTF Dixon	40	114	41	79	29	61	23	45	17
	Edwards AFB (a)	38	100	43	70	31	54	24	40	18
El Centro NAF (a)	60	157	62	183	66	144	51	108	37	

Table E-3

		Seismic Data (Site Class B)									
State	Base / City	PGA (%g)	S _s (%g)	S ₁ (%g)	S _{S,5/50} (%g)	S _{1,5/50} (%g)	S _{S,10/50} (%g)	S _{1,10/50} (%g)	S _{S,20/50} (%g)	S _{1,20/50} (%g)	
California	Fort Hunter Liggett	44	115	41	80	29	60	22	43	16	
	Fort Irwin (a)	38	98	38	70	27	51	20	35	14	
	Fresno ANG	22	61	25	40	17	30	13	23	10	
	NAS Lemoore	41	107	37	76	27	56	20	40	15	
	Los Angeles AFB / El Segundo	60	163	60	117	42	87	31	61	23	
	Los Angeles	74	202	73	147	52	109	38	76	27	
	March ARB	50	150	60	144	57	113	44	84	32	
	McClellan AFB / Sacramento	19	57	27	38	18	30	14	23	11	
	NWC Mohave Range (a)	57	140	55	101	38	69	25	45	16	
	Presidio of Monterey	61	154	57	113	41	80	29	53	19	
	Point Mugu / Port Hueneme	78	208	73	153	53	108	38	71	26	
	San Diego Region										
	NAS North Island	54	121	46	85	31	52	20	31	13	
NAB Coronado	56	124	48	86	31	52	20	31	13		
MCRD	55	122	47	84	31	51	20	32	13		
MCAS Miramar	44	106	41	74	28	49	20	33	14		
Naval Medical Ctr	53	120	46	82	30	50	20	31	13		
San Diego NS	49	112	43	78	28	49	19	31	13		
NS Point Loma	53	120	46	84	31	52	20	32	13		

Table E-3

		Seismic Data (Site Class B)								
State	Base / City	PGA (%g)	S _s (%g)	S ₁ (%g)	S _{S,5/50} (%g)	S _{1,5/50} (%g)	S _{S,10/50} (%g)	S _{1,10/50} (%g)	S _{S,20/50} (%g)	S _{1,20/50} (%g)
California	Moffett Field – Onizuka / Sunnyvale	50	150	60	144	53	115	41	87	30
	San Clemente Island Naval Reservation	29	71	26	49	17	35	13	24	10
	San Nicolas Island	20	52	22	35	15	26	12	19	9
	Seal Beach NWS	58	153	57	108	39	78	29	55	21
	Seal Beach NWS – Concord Detachment	62	163	60	173	59	131	44	93	32
	Sierra Army Depot / Herlong	37	95	34	69	24	50	17	33	12
	Stockton / San Joaquin	58	149	49	110	35	77	25	50	18
	Travis AFB	56	152	52	108	37	80	28	57	21
	MCB Twentynine Palms (a)	52	135	48	96	33	70	25	49	18
	Vandenberg AFB (a)	37	96	35	69	25	50	19	35	14
Colorado	Buckley AFB / Aurora	8	17	6	11	4	7	2	4	1
	Denver	9	18	6	11	4	7	3	4	1
	Fort Carson	9	18	6	12	4	7	3	5	2
	Cheyenne Mountain AS / NORAD	9	18	6	12	4	7	3	4	2
	Peterson AFB / Colorado Springs	9	17	6	11	4	7	3	4	2
	Schriever AFB	8	16	6	10	4	7	3	4	1

Table E-3

		Seismic Data (Site Class B)								
State	Base / City	PGA (%g)	S _s (%g)	S ₁ (%g)	S _{S,5/50} (%g)	S _{1,5/50} (%g)	S _{S,10/50} (%g)	S _{1,10/50} (%g)	S _{S,20/50} (%g)	S _{1,20/50} (%g)
Colorado	USAF Academy	10	19	6	12	4	7	3	4	2
Connecticut	NSB New London / Groton	8	16	6	10	4	6	2	3	1
Delaware	Dover AFB	6	12	5	8	3	5	2	3	1
District of Columbia	Washington Region									
	Bolling AFB	6	12	5	8	3	5	2	3	1
	Anacostia NS	6	12	5	8	3	5	2	3	1
	Fort McNair	6	12	5	8	3	5	2	3	1
	Marine Barracks	6	12	5	8	3	5	2	3	1
	NRL Washington	6	12	5	8	3	5	2	3	1
	NDW / Anacostia	6	12	5	8	3	5	2	3	1
	Pentagon	6	12	5	8	3	5	2	3	1
	Walter Reed	6	12	5	8	3	5	2	3	1
Florida	Avon Park AS	3	7	3	4	2	2	1	1	1
	Cape Canaveral AFS	3	7	4	4	3	3	1	1	1
	Eglin AFB	4	9	5	5	4	4	3	2	1
	Homestead	2	4	2	2	1	1	1	1	0.3
	Hurlburt Field	4	8	5	5	4	3	2	2	1
	NAS Jacksonville / MCSF Blount Island / Jacksonville	5	11	6	8	4	4	2	2	1
	NAS Key West	1	2	1	1	1	1	0.4	1	0.3
	MacDill AFB	3	6	3	3	2	2	1	1	1

Table E-3

		Seismic Data (Site Class B)								
State	Base / City	PGA (%g)	S _s (%g)	S ₁ (%g)	S _{S,5/50} (%g)	S _{1,5/50} (%g)	S _{S,10/50} (%g)	S _{1,10/50} (%g)	S _{S,20/50} (%g)	S _{1,20/50} (%g)
Florida	NAS Mayport	6	12	6	8	4	5	3	2	1
	HQ Southcom / Miami	2	4	2	2	1	1	1	1	0.3
	Orlando	4	8	4	5	3	3	1	1	1
	NAS Panama City	3	8	5	5	4	3	2	2	1
	Patrick AFB	3	7	4	4	2	2	1	1	1
	NAS Pensacola	4	9	5	5	4	3	2	2	1
	Tampa	3	6	3	4	2	2	1	1	1
	Tyndall AFB	3	7	5	5	3	3	2	2	1
	NAS Whiting Field / Milton	5	10	6	6	4	4	3	2	1
Georgia	MCLB Albany	5	11	6	7	5	5	3	3	2
	Athens NCSC	10	21	9	14	7	9	4	6	3
	Dobbins AFB / Atlanta NAS	10	20	9	14	7	9	4	6	3
	Fort Benning	5	12	7	8	5	6	3	4	2
	Fort Gordon	13	27	11	18	7	11	5	6	3
	Fort McPherson / Fort Gillem	8	18	9	12	6	8	4	5	2
	Fort Stewart	11	22	10	15	7	9	4	4	2
	Hunter Army Airfield / Savannah	16	31	12	21	8	11	4	5	2
NSB Kings Bay	6	13	7	9	5	5	3	3	1	

Table E-3

		Seismic Data (Site Class B)								
State	Base / City	PGA (%g)	S _s (%g)	S ₁ (%g)	S _{S,5/50} (%g)	S _{1,5/50} (%g)	S _{S,10/50} (%g)	S _{1,10/50} (%g)	S _{S,20/50} (%g)	S _{1,20/50} (%g)
Georgia	Moody AFB	5	11	6	7	4	5	3	3	2
	Robins AFB	7	15	8	10	6	7	4	4	2
Hawaii	PMRF Barking Sands, Kauai	9	17	5	12	3	8	2	5	1
	MCBH Kaneohe Bay	27	59	17	42	12	30	8	20	6
	Pearl Harbor Region:									
	Camp H.M. Smith	27	57	17	41	11	28	8	19	5
	Fort Shafter	27	58	17	41	12	29	8	19	5
	Hickam AFB	26	57	16	41	11	28	8	19	5
	Pearl Harbor	26	57	16	41	11	28	8	19	5
	Tripler AMC	27	58	17	41	12	29	8	19	5
	Pohakuloa Training Area	58	150	60	154	69	127	57	113	44
	Wahiawa Region:									
	Lualualei	25	54	15	38	10	27	7	17	5
	Wahiawa Naval Res	26	56	16	40	11	28	8	18	5
	Wheeler AFB	26	55	16	40	11	27	8	18	5
	Schofield Barracks	25	55	15	39	10	27	7	18	5
Idaho	ARD Bayview	16	37	12	25	8	16	6	10	4
	Boise ANG	12	30	10	20	7	14	5	10	4
	Mountain Home AFB	11	26	9	17	6	12	5	8	3
Illinois	Fort Sheridan / Chicago	6	12	6	7	4	5	3	3	1

Table E-3

		Seismic Data (Site Class B)								
State	Base / City	PGA (%g)	S _s (%g)	S ₁ (%g)	S _{S,5/50} (%g)	S _{1,5/50} (%g)	S _{S,10/50} (%g)	S _{1,10/50} (%g)	S _{S,20/50} (%g)	S _{1,20/50} (%g)
	Great Lakes	6	12	6	7	4	4	2	2	1
	Rock Island Arsenal	5	11	6	7	4	5	3	3	1
	Scott AFB	26	49	18	35	13	22	7	11	3
	Springfield	10	21	11	15	8	10	4	5	2
Indiana	Crane NWSC	14	29	12	20	9	13	5	7	3
	Grissom ARB	5	12	7	8	5	6	3	3	2
	Fort Benjamin Harrison / Indianapolis	7	15	8	11	6	7	4	4	2
Iowa	Des Moines	3	7	5	4	3	3	2	2	1
Kansas	Fort Leavenworth	5	11	6	7	4	5	3	3	1
	Fort Riley	8	15	6	8	4	5	2	3	1
	McConnell AFB	5	11	6	7	4	4	2	3	1
Kentucky	Fort Campbell (a)	25	49	20	36	14	21	8	10	3
	Fort Knox	10	22	11	16	8	10	5	6	3
	Louisville	10	21	11	15	8	10	5	6	3
	Richmond	9	19	9	13	7	8	4	5	2
Louisiana	Barksdale AFB	6	13	7	9	5	6	3	3	1
	Fort Polk / Leesville	5	10	6	7	4	4	2	2	1
	NAS JRB New Orleans / Belle Chasse	5	9	5	6	4	3	2	2	1
Maine	NAS Brunswick	12	23	8	14	5	9	3	5	2
	NRTF Cutler	13	23	7	13	5	8	3	4	2

Table E-3

		Seismic Data (Site Class B)								
State	Base / City	PGA (%g)	S _s (%g)	S ₁ (%g)	S _{S,5/50} (%g)	S _{1,5/50} (%g)	S _{S,10/50} (%g)	S _{1,10/50} (%g)	S _{S,20/50} (%g)	S _{1,20/50} (%g)
Maine	PNSY Kittery	15	27	8	16	5	9	3	5	2
	Winter Harbour NSGA	10	19	7	11	4	7	3	4	2
Maryland	Aberdeen Proving Ground	8	15	5	9	3	5	2	3	1
	Adelphi	6	12	5	8	3	5	2	3	1
	Andrews AFB	6	12	5	7	3	5	2	3	1
	Carderock NSWC / Bethesda	6	12	5	8	3	5	2	3	1
	Bloods Island	4	10	5	6	3	4	2	2	1
	Edgewood Arsenal	7	14	5	9	3	5	2	3	1
	Fort Detrick / Fredrick	6	13	5	8	3	5	2	3	1
	Fort Meade	6	12	5	8	3	5	2	3	1
	Indian Head NSWC	6	12	5	8	4	5	2	3	1
	Martin State ANG	7	14	5	8	3	5	2	3	1
	NS Pax River , Webster Field / St. Inigoes	5	11	5	7	3	4	2	2	1
	U.S. Naval Academy / Annapolis	6	12	5	8	3	5	2	3	1
Massachusetts	Fort Devens / Ayer	11	21	7	13	5	8	3	5	2
	Hanscom AFB	12	22	7	13	5	8	3	5	2
	Natick	10	20	7	12	4	7	3	4	2
	Otis AGB / Falmouth	8	16	6	10	4	6	2	3	1

Table E-3

		Seismic Data (Site Class B)								
State	Base / City	PGA (%g)	S _s (%g)	S ₁ (%g)	S _{S,5/50} (%g)	S _{1,5/50} (%g)	S _{S,10/50} (%g)	S _{1,10/50} (%g)	S _{S,20/50} (%g)	S _{1,20/50} (%g)
Massachusetts	Westover ARB	8	17	7	11	4	7	3	4	2
Michigan	Battle Creek	4	9	5	6	4	4	2	2	1
	Detroit Arsenal / Warren	4	9	5	6	3	4	2	2	1
	Selfridge ANG Base	4	9	5	6	3	4	2	2	1
Minnesota	Minneapolis – St Paul	2	5	3	3	2	2	1	1	1
Mississippi	Stennis / Bay St. Louis	5	10	6	6	4	4	2	2	1
	Columbus AFB	11	23	12	17	8	10	5	5	2
	Gulfport	5	10	6	6	4	4	2	2	1
	Jackson	8	16	9	11	6	7	4	3	2
	Keesler AFB	5	10	6	6	4	4	2	2	1
	NAS Meridian	9	18	9	12	6	8	4	4	2
	Pascagoula NS	5	10	6	6	4	4	2	2	1
	Vicksburg	8	16	9	11	6	7	3	3	2
Missouri	Fort Leonard Wood	13	26	13	19	9	11	5	5	2
	Kansas City	5	11	7	8	5	5	3	3	1
	Overland	20	39	16	28	11	17	6	9	3
	St. Louis	22	43	17	31	12	19	7	9	3
	Whiteman AFB	6	13	8	9	6	6	3	3	2
Montana	Great Falls ANG	7	19	7	13	5	9	4	7	3
	Malmstrom AFB	7	17	7	12	5	8	3	6	2
Nebraska	Offutt AFB	5	10	5	6	3	4	2	2	1
	Lincoln	7	13	5	8	3	4	2	2	1

Table E-3

		Seismic Data (Site Class B)								
State	Base / City	PGA (%g)	S _s (%g)	S ₁ (%g)	S _{S,5/50} (%g)	S _{1,5/50} (%g)	S _{S,10/50} (%g)	S _{1,10/50} (%g)	S _{S,20/50} (%g)	S _{1,20/50} (%g)
Nevada	NAS Fallon	29	78	27	54	19	40	15	29	11
	Indian Springs AFS	20	51	17	35	12	25	9	17	6
	Nellis AFB	21	53	17	36	12	24	8	15	6
	Nellis AF Range (a)	21	53	17	36	12	24	8	15	6
New Jersey	NWS Earle / Colts Neck	13	23	6	13	4	7	2	4	1
	Fort Dix / Trenton	11	20	6	12	4	7	2	3	1
	Fort Monmouth	13	23	6	13	4	7	2	4	1
	Lakehurst	11	20	6	11	4	7	2	3	1
	McGuire AFB	11	20	6	12	4	7	2	3	1
	Picatinny Arsenal	14	24	7	14	4	8	3	4	2
New Mexico	Albuquerque	18	44	13	30	9	18	6	11	3
	Cannon AFB	4	9	3	6	2	4	1	2	1
	Holloman AFB	13	31	10	19	6	12	4	7	2
	Kirtland AFB	19	47	14	29	9	18	6	11	3
	White Sands	18	46	14	22	7	13	4	7	2
New York	Buffalo	12	21	6	12	4	7	2	3	1
	Fort Drum	12	24	8	16	6	10	4	6	2
	Fort Hamilton / Brooklyn	16	27	7	15	4	8	3	4	1
	Griffis AFB / Rome	8	18	7	11	5	7	3	5	2
	NIAGARA FALLS IAP	12	21	6	12	4	7	2	3	1
	NSU Saratoga Springs	10	21	8	13	5	9	3	5	2

Table E-3

		Seismic Data (Site Class B)								
State	Base / City	PGA (%g)	S _s (%g)	S ₁ (%g)	S _{S,5/50} (%g)	S _{1,5/50} (%g)	S _{S,10/50} (%g)	S _{1,10/50} (%g)	S _{S,20/50} (%g)	S _{1,20/50} (%g)
New York	Stewart ANG / Newburgh	11	21	7	13	4	7	3	4	2
	Syracuse	6	14	6	9	4	6	3	4	2
	West Point	13	23	7	13	4	8	3	4	2
	Watervliet Arsenal / Albany	9	19	7	12	5	8	3	5	2
North Carolina	MCAS Cherry Point	6	12	6	8	4	5	2	2	1
	Fort Bragg	11	21	10	15	6	8	4	4	2
	Harvey Point	4	10	5	6	3	4	2	2	1
	Jacksonville Region									
	MCB Camp Lejeune	7	15	7	10	5	5	3	3	1
	MCAS New River	8	15	7	10	5	6	3	3	1
	Pope AFB	11	21	10	15	6	8	4	4	2
	Raleigh	7	15	8	11	5	6	3	3	2
	Seymour Johnson AFB	7	15	7	10	5	6	3	3	1
North Dakota	Grand Forks AFB	2	4	2	2	1	1	1	1	0.4
	NRTF La Moure	2	4	2	2	1	1	1	1	0.4
	Minot AFB	2	5	2	3	1	2	1	1	0.5
Ohio	Cleveland	10	17	6	10	4	6	3	3	2
	DSC Whitehall / Columbus	5	12	6	8	4	5	3	3	2
	Wright-Patterson AFB	8	16	7	10	5	6	3	4	2

Table E-3

		Seismic Data (Site Class B)								
State	Base / City	PGA (%g)	S _s (%g)	S ₁ (%g)	S _{S,5/50} (%g)	S _{1,5/50} (%g)	S _{S,10/50} (%g)	S _{1,10/50} (%g)	S _{S,20/50} (%g)	S _{1,20/50} (%g)
Ohio	Youngstown ARS / Vienna	10	18	6	10	4	6	3	3	2
Oklahoma	Altus AFB	8	16	6	9	4	5	2	3	1
	Fort Sill	18	42	12	13	5	7	3	3	1
	McAlester Army Ammunition Plant	9	18	8	11	5	7	3	4	2
	Tinker AFB / Oklahoma City	16	27	8	16	5	9	3	4	2
	Tulsa	6	13	7	9	5	6	3	3	2
	Vance AFB	9	17	6	10	4	6	3	3	1
Oregon	Portland	42	96	40	71	30	48	20	30	11
Pennsylvania	ARS Coraopolis / Pittsburg	5	11	5	7	4	5	3	3	2
	Carlisle Barracks	6	13	5	8	3	5	2	3	1
	Fort Indiantown Gap / Annville	8	16	6	9	4	6	2	3	1
	Letterkenny / Chambersburg	6	12	5	8	3	5	2	3	1
	Mechanicsburg	7	14	5	8	4	5	2	3	1
	Philadelphia	11	21	6	12	4	7	2	4	1
	New Cumberland / Defense Depot Susquehanna	7	14	5	9	4	5	2	3	1
	Tobyhanna Army Depot	9	17	6	10	4	6	3	4	2

Table E-3

		Seismic Data (Site Class B)								
State	Base / City	PGA (%g)	S _s (%g)	S ₁ (%g)	S _{S,5/50} (%g)	S _{1,5/50} (%g)	S _{S,10/50} (%g)	S _{1,10/50} (%g)	S _{S,20/50} (%g)	S _{1,20/50} (%g)
Pennsylvania	Willow Grove ARS / NAS	12	21	6	12	4	7	2	4	1
Rhode Island	NS Newport	8	16	6	10	4	6	2	3	1
South Carolina	MCAS Beaufort	32	56	19	35	11	18	5	7	2
	Charleston Region:									
	Charleston AFB	101	147	49	86	24	34	8	11	3
	NWS Charleston	111	158	53	95	27	35	9	11	3
	Columbia Region:									
	McEntire	25	46	15	32	10	18	6	8	3
	Fort Jackson	23	42	15	29	10	17	6	8	3
	Shaw AFB	28	50	17	34	11	18	6	8	3
	MCRD Parris Island	27	49	17	31	10	16	5	7	2
South Dakota	Ellsworth AFB	6	12	4	7	3	5	2	3	1
Tennessee	Arnold AFB	12	25	12	18	9	12	5	7	3
	NSWC LCC / Memphis	50	101	35	71	24	35	10	13	4
	NSA Mid-South / Millington	56	113	39	79	26	40	12	15	4
	Nashville	14	29	14	21	10	13	6	7	3
Texas	NAS JRB, Carswell / Fort Worth	4	9	5	6	3	4	2	2	1
	NAS Corpus Christi	3	6	2	3	1	2	1	1	0.3

Table E-3

		Seismic Data (Site Class B)								
State	Base / City	PGA (%g)	S _s (%g)	S ₁ (%g)	S _{S,5/50} (%g)	S _{1,5/50} (%g)	S _{S,10/50} (%g)	S _{1,10/50} (%g)	S _{S,20/50} (%g)	S _{1,20/50} (%g)
Texas	Dallas / Irving	5	10	5	6	4	4	2	2	1
	Dyess AFB	3	7	4	4	2	3	2	2	1
	Ellington ANG / Houston	3	7	4	4	3	3	2	1	1
	Fort Bliss / El Paso	13	30	9	20	6	13	4	7	2
	Fort Hood / Killeen	3	6	4	4	3	3	2	1	1
	Goodfellow AFB	3	6	3	4	2	2	1	1	1
	NS Ingleside	3	6	2	3	1	2	1	1	0.3
	NAS Kingsville	3	6	2	3	1	2	1	1	0.3
	Laughlin AFB	2	5	2	3	1	2	1	1	0.4
	Red River Army Depot / Texarkana	7	14	8	10	6	6	3	3	2
San Antonio Region	Brooks AFB	4	9	3	4	2	2	1	1	1
	Fort Sam Houston	4	8	3	4	2	2	1	1	1
	Kelly AFB	4	8	3	4	2	2	1	1	0.5
	Lackland AFB	4	8	3	4	2	2	1	1	0.4
	Randolph AFB	4	8	3	4	2	2	1	1	1
	Sheppard AFB	7	14	6	8	4	5	2	3	1
Utah	Dugway Proving Ground	15	37	14	26	10	18	7	12	5
	Hill AFB	54	129	43	82	27	48	16	28	9
	Salt Lake City	49	119	44	85	30	51	17	28	9

Table E-3

		Seismic Data (Site Class B)								
State	Base / City	PGA (%g)	S _s (%g)	S ₁ (%g)	S _{S,5/50} (%g)	S _{1,5/50} (%g)	S _{S,10/50} (%g)	S _{1,10/50} (%g)	S _{S,20/50} (%g)	S _{1,20/50} (%g)
Utah	Tooele Army Depot	30	77	26	51	18	35	12	22	8
Virginia	Dahlgren	6	12	5	8	4	5	2	3	1
	Dam Neck / Virginia Beach Ocean front	4	9	5	6	3	3	2	2	1
	Fort A. P. Hill	7	15	6	9	4	5	2	3	1
	Fort Belvoir	6	12	5	8	3	5	2	3	1
	Fort Eustis	5	11	5	7	3	4	2	2	1
	Fort Lee	8	16	6	9	4	6	2	3	1
	Fort Monroe	4	10	5	6	3	4	2	2	1
	Fort Myer	6	12	5	8	3	5	2	3	1
	Fort Story	4	9	5	6	3	4	2	2	1
	Henderson Hall / Arlington	6	12	5	8	3	5	2	3	1
	Langley AFB / Hampton	5	10	5	6	3	4	2	2	1
	NAB Little Creek	4	9	5	6	3	4	2	2	1
	Norfolk Region:									
	Camp Elmore	4	10	5	6	3	4	2	2	1
	Craney Island Depot	5	10	5	6	3	4	2	2	1
	Norfolk Naval Base	4	10	5	6	3	4	2	2	1
	Norfolk Shipyard – Naval Hospital / Portsmouth	4	10	5	6	3	4	2	2	1
	NSA Northwest / Chesapeake	4	9	5	6	3	4	2	2	1

Table E-3

		Seismic Data (Site Class B)								
State	Base / City	PGA (%g)	S _s (%g)	S ₁ (%g)	S _{S,5/50} (%g)	S _{1,5/50} (%g)	S _{S,10/50} (%g)	S _{1,10/50} (%g)	S _{S,20/50} (%g)	S _{1,20/50} (%g)
Virginia	NAS Oceana / Virginia Beach	4	9	5	6	3	4	2	2	1
	MCB Quantico	6	13	5	8	4	5	2	3	1
	Defense Supply Ctr / Richmond	10	19	6	10	4	6	3	3	1
	Radford AAP	14	25	9	15	6	9	4	5	2
	Wallops Island	4	8	4	5	3	3	2	2	1
	Yorktown Region:									
	Camp Peary	5	11	5	7	4	4	2	3	1
	Cheatham Annex	5	11	5	7	3	4	2	2	1
	Yorktown NWS	5	10	5	7	3	4	2	2	1
	Washington	NS Everett	55	133	50	92	36	65	25	44
Fairchild AFB		14	32	12	21	8	14	5	9	3
Fort Lewis / Tacoma		50	128	51	92	37	68	26	48	18
Indian Island SWC		54	130	53	94	38	69	27	47	18
NRS Jim Creek		47	116	45	84	33	61	23	42	16
Keyport / Bangor Engin. Sta Annex		52	133	53	96	39	72	28	50	19
McChord AFB		50	128	50	92	36	69	26	48	18

Table E-3

		Seismic Data (Site Class B)								
State	Base / City	PGA (%g)	S _s (%g)	S ₁ (%g)	S _{S,5/50} (%g)	S _{1,5/50} (%g)	S _{S,10/50} (%g)	S _{1,10/50} (%g)	S _{S,20/50} (%g)	S _{1,20/50} (%g)
Washington	Puget Sound Region: Bangor NSB	66	157	61	109	43	76	30	52	19
	Bremerton NS	63	152	60	107	43	76	30	52	20
	Puget Sound NSY	66	157	61	109	43	77	30	52	20
	NAS Whidbey Island / Oak Harbor	54	129	51	93	37	66	26	44	16
	Seattle	60	144	56	101	40	73	28	49	18
West Virginia	Allegheny Ballistics Lab	6	12	5	7	4	5	3	3	2
	Beckley	10	19	8	12	5	7	4	4	2
	Huntington	7	15	7	10	5	6	4	4	2
	Sugar Grove NRS	6	14	6	9	4	6	3	3	2
Wisconsin	Fort McCoy	3	5	4	3	3	2	2	1	1
	General Mitchell AFRC / Milwaukee	4	9	5	6	3	3	2	2	1
	Madison	4	8	5	5	3	3	2	2	1
Wyoming	F. E. Warren AFB	8	16	6	11	4	7	2	4	1
American Samoa	Pago Pago / Tutuila Island	17	41	16	30	11	21	8	14	6
Mariana Islands	Guam (b)	90	279	68	208	51	151	37	105	25
Mariana Islands	Saipan / Tinian	58	178	45	129	33	92	23	64	16
Puerto Rico	NRTF Aguada	49	131	50	91	35	68	26	48	19
	Fort Buchanan	41	100	40	71	29	53	22	38	15

Table E-3

		Seismic Data (Site Class B)								
State	Base / City	PGA (%g)	S _s (%g)	S ₁ (%g)	S _{S,5/50} (%g)	S _{1,5/50} (%g)	S _{S,10/50} (%g)	S _{1,10/50} (%g)	S _{S,20/50} (%g)	S _{1,20/50} (%g)
Puerto Rico	Ramey AFB	50	134	50	94	36	70	27	51	19
	NS Roosevelt Roads	40	98	37	69	27	52	20	37	14
	Sebana Seca NRS	41	101	40	72	29	54	22	38	15

Notes to TABLE E-3, "EARTHQUAKE LOADING DATA – UNITED STATES, ITS TERRITORIES AND POSSESSIONS"

(a) – Seismic parameters are provided at the geographic centroid of the installation. However, due to the size of the installation and the considerable variation of the seismic accelerations over short distances within the installation, location specific parameters shall be determined using the USGS U.S. Seismic Design Map Web Application, which could result in higher seismic parameters than provided in this table.

\3\

(b) – Acceleration values indicated for Guam may be reduced by 20% based on a site specific ground motion study conducted by URS Corporation dated April 1, 2016, and per ASCE 7-10 21.4.

/3/

APPENDIX F SITE-SPECIFIC STRUCTURAL LOADING DATA – OUTSIDE OF THE UNITED STATES, ITS TERRITORIES AND POSSESSIONS

F-1 WIND LOADING DATA TABLE.

Site-specific structural wind loading data for potential DoD locations outside of the United States, its territories and possessions is provided in Table F-1.

F-2 SNOW LOADING AND FROST PENETRATION DATA TABLE.

Site-specific structural snow loading and frost penetration data for potential DoD locations outside of the United States, its territories and possessions is provided in Table F-2.

F-3 EARTHQUAKE LOADING DATA TABLE.

Site-specific earthquake loading data for potential DoD locations outside of the United States, its territories and possessions is provided in Table F-3.

CANCELLED

TABLE F-1 - WIND LOADING DATA – OUTSIDE OF THE UNITED STATES, ITS TERRITORIES AND POSSESSIONS

TABLE F-1			Wind Speed (mph) - Note (a)				Wind Speed (km/h) - Note (a)			
			Risk Category				Risk Category			
Continent / Region	Country	Base / City	I	II	III-IV	V	I	II	III-IV	V
Africa	Djibouti	Djibouti	106	114	122	148	171	183	196	238
	Egypt	Alexandria	100	110	115	140	161	177	185	225
	Morocco	Casablanca	106	114	122	148	171	183	196	238
Asia	Afghanistan	Kabul	100 (92)	110 (99)	115 (105)	140 (128)	161 (148)	177 (159)	185 (170)	225 (206)
	Bahrain	NSA Bahrain	100	110	115	140	161	177	185	225
	India	Bombay (Mumbai)	107	115	123	150	173	185	198	241
		Calcutta (Kolkata)	134	144	154	187	216	232	248	302
		Madras (Chennai)	108	116	124	151	175	187	200	243
		New Delhi	107	115	123	150	173	185	198	241
	Iraq	Baghdad	100 (0)	110 (0)	115 (0)	140 (0)	161 (0)	177 (0)	185 (0)	225 (0)
		Basra	100 (0)	110 (0)	115 (0)	140 (0)	161 (0)	177 (0)	185 (0)	225 (0)
	Japan	NAF Atsugi	118	126	135	164	190	203	218	265
		MCAS Iwakuni	141	152	162	197	228	244	261	318
		Iwo Jima	248	265	284	345	398	427	457	556
		Misawa AFB	119	128	137	166	192	205	220	267
		Okinawa (All installations)	212	227	243	296	341	366	392	476

TABLE F-1

Continent / Region	Country	Base / City	Wind Speed (mph) - Note (a)				Wind Speed (km/h) - Note (a)			
			Risk Category				Risk Category			
			I	II	III-IV	V	I	II	III-IV	V
		Sagamihara	118	126	135	164	190	203	218	265
Asia	Japan	Sasebo	118	126	135	164	190	203	218	265
		Tokyo	118	126	135	164	190	203	218	265
		COMFLTACT Yokosuka	118	126	135	164	190	203	218	265
		Yokota AFB, Honshu	118	126	135	164	190	203	218	265
		Camp Zama	118	126	135	164	190	203	218	265
	Kuwait	Kuwait City	100 (0)	110 (0)	115 (0)	140 (0)	161 (0)	177 (0)	185 (0)	225 (0)
	Oman	Areas south and west of Jabal Akehadar								
		- Ibri	124	133	142	173	199	214	229	278
		- Nazwa	124	133	142	173	199	214	229	278
		Batinah Coast								
		- Ash Shinash	124	133	142	173	199	214	229	278
		- Sib	124	133	142	173	199	214	229	278
		- Suhar	124	133	142	173	199	214	229	278
		Central, Southern, and Coastal Areas Sur to Sarfait								
		- Barik	136	145	156	189	218	234	250	304
		- Dawqa	136	145	156	189	218	234	250	304

TABLE F-1

Continent / Region	Country	Base / City	Wind Speed (mph) - Note (a)				Wind Speed (km/h) - Note (a)			
			Risk Category				Risk Category			
			I	II	III-IV	V	I	II	III-IV	V
		- Hayma	136	145	156	189	218	234	250	304
Asia	Oman	- Salalah	136	145	156	189	218	234	250	304
		- Shalim	136	145	156	189	218	234	250	304
		High Jabal Locations								
		- Miskin	136	145	156	189	218	234	250	304
		- Sumail	136	145	156	189	218	234	250	304
		- Rikshah	136	145	156	189	218	234	250	304
		- Shaww	136	145	156	189	218	234	250	304
		Kuria Muria Island	141	152	162	197	228	244	261	318
		Masirah Island	141	152	162	197	228	244	261	318
		Mussandam Island	141	152	162	197	228	244	261	318
	Pakistan	Peshawar	104	111	119	145	167	179	192	233
	Qatar	Doha	100 (0)	110 (0)	115 (0)	140 (0)	161 (0)	177 (0)	185 (0)	225 (0)
	Saudi Arabia	Dhahran	103	110	118	143	165	177	189	230
	Saudi Arabia	Hafr al Batin	100 (94)	110 (101)	115 (108)	140 (132)	161 (152)	177 (163)	185 (174)	225 (212)
		Khamis Mushayt	100 (94)	110 (101)	115 (108)	140 (132)	161 (152)	177 (163)	185 (174)	225 (212)
		Jeddah	100 (94)	110 (101)	115 (108)	140 (132)	161 (152)	177 (163)	185 (174)	225 (212)

TABLE F-1

Continent / Region	Country	Base / City	Wind Speed (mph) - Note (a)				Wind Speed (km/h) - Note (a)			
			Risk Category				Risk Category			
			I	II	III-IV	V	I	II	III-IV	V
Asia	Saudi Arabia	Jubail	100 (94)	110 (101)	115 (108)	140 (132)	161 (152)	177 (163)	185 (174)	225 (212)
		Qadimah	100 (94)	110 (101)	115 (108)	140 (132)	161 (152)	177 (163)	185 (174)	225 (212)
		Riyadh	100 (94)	110 (101)	115 (108)	140 (132)	161 (152)	177 (163)	185 (174)	225 (212)
		Tabuk	100 (94)	110 (101)	115 (108)	140 (132)	161 (152)	177 (163)	185 (174)	225 (212)
	South Korea	Camp Casey	124	133	142	173	199	214	229	278
		Camp Hialeah, Busan	130	139	149	181	209	224	239	291
		Camp Humphreys / Pyongtaek	112	120	128	156	180	193	207	251
		Chinhae	124	133	142	173	199	214	229	278
		Kimpo AFB	124	133	142	173	199	214	229	278
		Kunsan / Kunsan City	118	126	135	164	190	203	218	265
		Osan AFB / Songtan	112	120	128	156	180	193	207	251
		Pohang	130	139	149	181	209	224	239	291
		Seoul	124	133	142	173	199	214	229	278
		Taegu	136	145	156	189	218	234	250	304
		Uijongbu	124	133	142	173	199	214	229	278

TABLE F-1

Continent / Region	Country	Base / City	Wind Speed (mph) - Note (a)				Wind Speed (km/h) - Note (a)			
			Risk Category				Risk Category			
			I	II	III-IV	V	I	II	III-IV	V
Asia	South Korea	Yongsan	124	133	142	173	199	214	229	278
	Vietnam	Da Nang	141	152	162	197	228	244	261	318
		Ho Chi Minh City	112	120	128	156	180	193	207	251
		Nha Trang	112	120	128	156	180	193	207	251
	Taiwan	Tainan	141	152	162	197	228	244	261	318
		Taipei	153	164	176	214	247	264	283	344
		Tsoying	130	139	149	181	209	224	239	291
	Thailand	Bangkok	100 (94)	110 (101)	115 (108)	140 (132)	161 (152)	177 (163)	185 (174)	225 (212)
		Chiang Mai	112	120	128	156	180	193	207	251
		Sattahip	100	110	115	140	161	177	185	225
		Udonthani	100	110	115	140	161	177	185	225
		Turkey	Ankara	117	125	134	163	188	201	215
	Incirlik AB / Adana		100 (83)	110 (88)	115 (95)	140 (115)	161 (133)	177 (142)	185 (152)	225 (185)
			Izmir AS	100 (0)	110 (0)	115 (0)	140 (0)	161 (0)	177 (0)	185 (0)
Karamursel	112		120	128	156	180	193	207	251	
Central America	Canal Zone	112	120	128	156	180	193	207	251	
Europe	Belgium	Brussels	100 (0)	110 (0)	115 (0)	140 (0)	161 (0)	177 (0)	185 (0)	225 (0)
		Kester	100 (0)	110 (0)	115 (0)	140 (0)	161 (0)	177 (0)	185 (0)	225 (0)
		Kleine Brogel	100 (0)	110 (0)	115 (0)	140 (0)	161 (0)	177 (0)	185 (0)	225 (0)

TABLE F-1

Continent / Region	Country	Base / City	Wind Speed (mph) - Note (a)				Wind Speed (km/h) - Note (a)			
			Risk Category				Risk Category			
			I	II	III-IV	V	I	II	III-IV	V
Europe	Belgium	Shape - Chievres	100 (0)	110 (0)	115 (0)	140 (0)	161 (0)	177 (0)	185 (0)	225 (0)
	Bosnia - Herzegovina	Tuzla AFB	100 (0)	110 (0)	115 (0)	140 (0)	161 (0)	177 (0)	185 (0)	225 (0)
	England	RAF Alconbury, Molesworth / Huntingdon	100 (0)	110 (0)	115 (0)	140 (0)	161 (0)	177 (0)	185 (0)	225 (0)
		Birmingham	105	112	120	146	169	181	194	236
		RAF Croughton / Brackley	118	126	135	164	190	203	218	265
		RAF Fairford	100 (0)	110 (0)	115 (0)	140 (0)	161 (0)	177 (0)	185 (0)	225 (0)
		RAF Lakenheath / Lakeheath Village	118	126	135	164	190	203	218	265
		USNA UK / London	112	120	128	156	180	193	207	251
		RAF Menwith Hill / Harrogate	100 (0)	110 (0)	115 (0)	140 (0)	161 (0)	177 (0)	185 (0)	225 (0)
		RAF Mildenhall	123	131	141	171	197	211	226	275
		Plymouth	111	119	127	155	178	191	205	249
		RAF Upwood / Ramsey	100 (0)	110 (0)	115 (0)	140 (0)	161 (0)	177 (0)	185 (0)	225 (0)

TABLE F-1

Continent / Region	Country	Base / City	Wind Speed (mph) - Note (a)				Wind Speed (km/h) - Note (a)			
			Risk Category				Risk Category			
			I	II	III-IV	V	I	II	III-IV	V
Europe	England	JMF St. Mawgan / Cornwall	100 (0)	110 (0)	115 (0)	140 (0)	161 (0)	177 (0)	185 (0)	225 (0)
		Sculthorpe AB	117	125	134	163	188	201	215	262
		Southport	123	131	141	171	197	211	226	275
		South Shields	117	125	134	163	188	201	215	262
		Spurn Head	117	125	134	163	188	201	215	262
	Germany	Ansbach	100 (0)	110 (0)	115 (0)	140 (0)	161 (0)	177 (0)	185 (0)	225 (0)
		Bamberg	100 (0)	110 (0)	115 (0)	140 (0)	161 (0)	177 (0)	185 (0)	225 (0)
		Baumholder	100 (0)	110 (0)	115 (0)	140 (0)	161 (0)	177 (0)	185 (0)	225 (0)
		Bremen	100	110	115	140	161	177	185	225
		Buechel Air Base / Cochem	100 (0)	110 (0)	115 (0)	140 (0)	161 (0)	177 (0)	185 (0)	225 (0)
		Darmstadt	100 (0)	110 (0)	115 (0)	140 (0)	161 (0)	177 (0)	185 (0)	225 (0)
		Garmisch AST	100 (0)	110 (0)	115 (0)	140 (0)	161 (0)	177 (0)	185 (0)	225 (0)
		Geilenkirchen	100 (0)	110 (0)	115 (0)	140 (0)	161 (0)	177 (0)	185 (0)	225 (0)
		Grafenwoehr	106	114	122	148	171	183	196	238
		Hanau	100 (65)	110 (69)	115 (74)	140 (90)	161 (104)	177 (112)	185 (120)	225 (146)
	Heidelberg	100 (65)	110 (69)	115 (74)	140 (90)	161 (104)	177 (112)	185 (120)	225 (146)	
	Hohenfels	100 (0)	110 (0)	115 (0)	140 (0)	161 (0)	177 (0)	185 (0)	225 (0)	
	Illesheim	100 (0)	110 (0)	115 (0)	140 (0)	161 (0)	177 (0)	185 (0)	225 (0)	

TABLE F-1

Continent / Region	Country	Base / City	Wind Speed (mph) - Note (a)				Wind Speed (km/h) - Note (a)				
			Risk Category				Risk Category				
			I	II	III-IV	V	I	II	III-IV	V	
Europe	Germany	Kaiserslautern	100 (0)	110 (0)	115 (0)	140 (0)	161 (0)	177 (0)	185 (0)	225 (0)	
		Kalkar	100 (0)	110 (0)	115 (0)	140 (0)	161 (0)	177 (0)	185 (0)	225 (0)	
		Mannheim	100 (0)	110 (0)	115 (0)	140 (0)	161 (0)	177 (0)	185 (0)	225 (0)	
		Munich	116	124	133	161	186	199	213	259	
		Ramstein AB	100 (0)	110 (0)	115 (0)	140 (0)	161 (0)	177 (0)	185 (0)	225 (0)	
		Rhein-Main Air Base	100	110	115	140	161	177	185	225	
		Schweinfurt	100 (0)	110 (0)	115 (0)	140 (0)	161 (0)	177 (0)	185 (0)	225 (0)	
		Spangdahlem Air Base	100 (65)	110 (69)	115 (74)	140 (90)	161 (104)	177 (112)	185 (120)	225 (146)	
		Stuttgart	106	114	122	148	171	183	196	238	
		Vilseck	100 (0)	110 (0)	115 (0)	140 (0)	161 (0)	177 (0)	185 (0)	225 (0)	
		Wiesbaden / Mainz / Dexheim	100 (0)	110 (0)	115 (0)	140 (0)	161 (0)	177 (0)	185 (0)	225 (0)	
		Wuerzburg / Kitzingen / Giebelstadt	106	114	122	148	171	183	196	238	
		Greece	Athens	108	116	124	151	175	187	200	243
			Larissa	100 (0)	110 (0)	115 (0)	140 (0)	161 (0)	177 (0)	185 (0)	225 (0)
		NAS Souda Bay / Mouzouras	101	110	116	141	163	177	187	228	
Iceland	Keflavik - NSA	136	145	156	189	218	234	250	304		
	Thorshofn	172	184	197	240	277	297	318	386		

TABLE F-1

Continent / Region	Country	Base / City	Wind Speed (mph) - Note (a)				Wind Speed (km/h) - Note (a)			
			Risk Category				Risk Category			
			I	II	III-IV	V	I	II	III-IV	V
Europe	Italy	Aviano AB	100 (94)	110 (101)	115 (108)	140 (132)	161 (152)	177 (163)	185 (174)	225 (212)
		Brindisi / San Vito	130	139	149	181	209	224	239	291
		Camp Darby Livorno	100 (0)	110 (0)	115 (0)	140 (0)	161 (0)	177 (0)	185 (0)	225 (0)
		Gaeta - NSA	100 (94)	110 (101)	115 (108)	140 (132)	161 (152)	177 (163)	185 (174)	225 (212)
		Gheddi	100 (0)	110 (0)	115 (0)	140 (0)	161 (0)	177 (0)	185 (0)	225 (0)
		NSA La Maddalena	100 (94)	110 (101)	115 (108)	140 (132)	161 (152)	177 (163)	185 (174)	225 (212)
		NSA Naples	100 (94)	110 (101)	115 (108)	140 (132)	161 (152)	177 (163)	185 (174)	225 (212)
		Niscemi	106	114	122	148	171	183	196	238
		NAS Sigonella	106	114	122	148	171	183	196	238
		Vicenza	100 (94)	110 (101)	115 (108)	140 (132)	161 (152)	177 (163)	185 (174)	225 (212)
	Netherlands	Volkel Air Base	100 (0)	110 (0)	115 (0)	140 (0)	161 (0)	177 (0)	185 (0)	225 (0)
		AF North Brunssum	100 (0)	110 (0)	115 (0)	140 (0)	161 (0)	177 (0)	185 (0)	225 (0)
		Schinnen	100 (83)	110 (88)	115 (95)	140 (115)	161 (133)	177 (142)	185 (152)	225 (185)
	Northern Ireland	Londonderry	157	168	180	219	252	270	289	352

TABLE F-1

Continent / Region	Country	Base / City	Wind Speed (mph) - Note (a)				Wind Speed (km/h) - Note (a)			
			Risk Category				Risk Category			
			I	II	III-IV	V	I	II	III-IV	V
Europe	Norway	Stavanger	100 (0)	110 (0)	115 (0)	140 (0)	161 (0)	177 (0)	185 (0)	225 (0)
	Portugal	Azores / Lajes Field	141	152	162	197	228	244	261	318
		Southlant / Oeiras	100 (0)	110 (0)	115 (0)	140 (0)	161 (0)	177 (0)	185 (0)	225 (0)
	Scotland	Aberdeen	106	114	122	148	171	183	196	238
		Edinburgh	117	125	134	163	188	201	215	262
		Edzell	100	110	115	140	161	177	185	225
		Glasgow	117	125	134	163	188	201	215	262
		Prestwick	118	126	135	164	190	203	218	265
		Stornoway	141	152	162	197	228	244	261	318
		Thurso	124	133	142	173	199	214	229	278
	Spain	Madrid / JHQ SW	100 (98)	110 (105)	115 (112)	140 (136)	161 (157)	177 (169)	185 (181)	225 (220)
		Moron AB	100 (0)	110 (0)	115 (0)	140 (0)	161 (0)	177 (0)	185 (0)	225 (0)
		NS Rota	106	114	122	148	171	183	196	238
		San Pablo	138	148	158	192	222	238	255	310
		HRF Valencia	100 (0)	110 (0)	115 (0)	140 (0)	161 (0)	177 (0)	185 (0)	225 (0)
	Spain	Zaragoza	138	148	158	192	222	238	255	310
North America	Canada	Argentia NAS, Newfoundland	136	145	156	189	218	234	250	304
		Churchill, Manitoba	126	135	145	176	203	218	233	283

TABLE F-1

Continent / Region	Country	Base / City	Wind Speed (mph) - Note (a)				Wind Speed (km/h) - Note (a)			
			Risk Category				Risk Category			
			I	II	III-IV	V	I	II	III-IV	V
North America	Canada	Cold Lake, Alberta	100 (95)	110 (102)	115 (110)	140 (133)	161 (154)	177 (165)	185 (176)	225 (214)
		Edmonton, Alberta	100 (99)	110 (106)	115 (114)	140 (138)	161 (159)	177 (171)	185 (183)	225 (222)
		E. Harmon AFB, Newfoundland	133	143	153	186	214	230	246	299
		Fort William, Ontario	100 (95)	110 (102)	115 (110)	140 (133)	161 (154)	177 (165)	185 (176)	225 (214)
		Frobisher, NWT	126	135	145	176	203	218	233	283
		Goose Airport, Newfoundland	105	112	120	146	169	181	194	236
		Ottawa, Ontario	106	114	122	148	171	183	196	238
		St. John's, Newfoundland	134	144	154	187	216	232	248	302
		Toronto, Ontario	106	114	122	148	171	183	196	238
		Winnipeg, Manitoba	100 (97)	110 (104)	115 (111)	140 (135)	161 (156)	177 (167)	185 (178)	225 (217)
	Greenland	Narsarsuak AB	164	176	188	229	264	283	303	368
		Simiutak AB	196	210	224	273	315	338	361	439
		Sondrestrom AB	141	152	162	197	228	244	261	318

TABLE F-1

Continent / Region	Country	Base / City	Wind Speed (mph) - Note (a)				Wind Speed (km/h) - Note (a)			
			Risk Category				Risk Category			
			I	II	III-IV	V	I	II	III-IV	V
North America	Greenland	Thule AB	159	171	183	222	256	275	294	357
Atlantic Ocean	Ascension Island		100 (79)	110 (85)	115 (91)	140 (110)	161 (127)	177 (136)	185 (146)	225 (177)
Caribbean Sea	The Bahamas	Eleuthera Island	174	187	200	243	281	301	322	392
		Grand Bahama Island	174	187	200	243	281	301	322	392
		Grand Turk Island	190	203	218	265	305	327	350	426
Caribbean Sea	The Bahamas	Great Exuma Island	174	187	200	243	281	301	322	392
	Cuba	NS Guantanamo Bay	124	133	142	173	199	214	229	278
	Trinidad Island	Port of Spain	100 (70)	110 (75)	115 (80)	140 (97)	161 (112)	177 (120)	185 (128)	225 (156)
Indian Ocean	British Indian Ocean Territory	NSF Diego Garcia	124	133	142	173	199	214	229	278
Pacific Ocean	Australia	H.E. Holt / N.W. Cape	153	164	176	214	247	264	283	344
		Woomera	100 (94)	110 (101)	115 (108)	140 (132)	161 (152)	177 (163)	185 (174)	225 (212)
	Caroline Islands	Koror, Paulau Islands	112	120	128	156	180	193	207	251

TABLE F-1

Continent / Region	Country	Base / City	Wind Speed (mph) - Note (a)				Wind Speed (km/h) - Note (a)			
			Risk Category				Risk Category			
			I	II	III-IV	V	I	II	III-IV	V
Pacific Ocean	Caroline Islands	Ponape	130	139	149	181	209	224	239	291
	Johnston Atoll		112	120	128	156	180	193	207	251
	Marcus Island		177	190	203	247	285	305	326	397
	Marshall Islands	Kwajalein	124	133	142	173	199	214	229	278
		Wake Island	130	139	149	181	209	224	239	291
	Midway Island		112	120	128	156	180	193	207	251
	Philippine Islands	Clark AFB	106	114	122	148	171	183	196	238
		Sangley Point	106	114	122	148	171	183	196	238
		Subic Bay	106	114	122	148	171	183	196	238
	Samoa	Apia / Upolu	177	190	203	247	285	305	326	397

Notes to Table F-1, "WIND LOADING DATA – OUTSIDE OF THE UNITED STATES, ITS TERRITORIES AND POSSESSIONS"

Note (a) – Use a minimum wind speed of 100 mph (161 km/h) for Risk Category I, 110 mph (177 km/h) for Risk Category II, 115 mph (185 km/h) for Risk Category III and IV or 140 mph (225 km/h) for Risk Category V for all locations unless a lower wind speed is approved by the AHJ. Wind speeds shown in parenthesis are local data that are less than the minimum wind speed and may only be used if approved by the AHJ. Where there is a zero in the parenthesis, no local data is currently available.

TABLE F-2 – SNOW LOADING AND FROST PENETRATION DATA – OUTSIDE OF THE UNITED STATES, ITS TERRITORIES AND POSSESSIONS

TABLE F-2

			Ground Snow	Frost Penetration (a)	Ground Snow	Frost Penetration (a)		
Continent / Region	Country	Base / City	(psf)	(in)	(kPa)	(mm)		
Africa	Djibouti	Djibouti	0	0	0	0		
	Egypt	Alexandria	0	0	0	0		
	Morocco	Casablanca	0	0	0	0		
Asia	Afghanistan	Kabul						
	Bahrain	NSA Bahrain	0	0	0	0		
	India	Bombay (Mumbai)		0	0	0	0	
		Calcutta (Kolkata)		0	0	0	0	
		Madras (Chennai)		0	0	0	0	
		New Delhi		0	0	0	0	
	Iraq	Baghdad						
		Basra						
	Japan	NAF Atsugi		21	6	1	152	
		MCAS Iwakuni		12	10	0.57	254	
		Iwo Jima		0	0	0	0	
		Misawa AFB		58	30	2.78	762	
		Okinawa (All installations)		0	0	0	0	
		Sagamihara	Sagamihara		21	6	1	152
			Sasebo		12	6	0.57	152
Tokyo			15	6	0.71	152		
COMFLTACT Yokosuka			12	6	0.57	152		
Yokota AFB, Honshu			21	6	1	161		
	Camp Zama		21	6	1.00	152		
	Kuwait	Kuwait City	0	0	0	0		
	Oman	Areas south and west of Jabal						

TABLE F-2

			Ground Snow	Frost Penetration (a)	Ground Snow	Frost Penetration (a)
Continent / Region	Country	Base / City	(psf)	(in)	(kPa)	(mm)
		Akehadar				
		- Ibri	0	0	0	0
		- Nazwa	0	0	0	0
		Batinah Coast				
		- Ash Shinash	0	0	0	0
		- Sib	0	0	0	0
		- Suhar	0	0	0	0
		Central, Southern, and Coastal Areas Sur to Sarfait				
		- Barik	0	0	0	0
Asia	Oman	- Dawqa	0	0	0	0
		- Hayma	0	0	0	0
		- Salalah	0	0	0	0
		- Shalim	0	0	0	0
		High Jabal Locations				
		- Miskin	0	0	0	0
		- Sumail	0	0	0	0
		- Rikshah	0	0	0	0
		- Shaww	0	0	0	0
		Kuria Muria Island	0	0	0	0
		Masirah Island	0	0	0	0
		Mussandam Island	0	0	0	0
	Pakistan	Peshawar	10	6	0.48	152
	Qatar	Doha	0	0	0	0
	Saudi Arabia	Dhahran	0	0	0	0
		Hafr al Batin	0	0	0	0
		Khamis Mushayt	0	0	0	0

TABLE F-2

			Ground Snow	Frost Penetration (a)	Ground Snow	Frost Penetration (a)
Continent / Region	Country	Base / City	(psf)	(in)	(kPa)	(mm)
		Jeddah	0	0	0	0
		Jubail	0	0	0	0
Asia	Saudi Arabia	Qadimah	0	0	0	0
		Riyadh	0	0	0	0
		Tabuk	0	0	0	0
	South Korea	Camp Casey	20	48	0.96	1219
		Camp Hialeah, Pusan	20	24	0.96	610
		Camp Humphreys / Pyongyang	20	45	0.96	1143
		Chinhae	20	24	0.96	610
		Kimpo AFB	20	48	0.96	1219
		Kunsan / Kunsan City	20	30	0.96	762
		Osan AFB / Songtan	20	45	0.96	1143
		Pohang	20	24	0.96	610
		Seoul	20	48	0.96	1219
		Taegu	20	40	0.96	1016
		Uijongbu	20	48	0.96	1219
		Yongsan	20	45	0.96	1143
	Vietnam	Da Nang	0	0	0	0
		Ho Chi Minh City	0	0	0	0
		Nha Trang	0	0	0	0
Asia	Taiwan	Tainan	0	0	0	0
		Taipei	0	0	0	0
		Tsoying	0	0	0	0
	Thailand	Bangkok	0	0	0	0
		Chiang Mai	0	0	0	0
		Sattahip	0	0	0	0
		Udonthani	0	0	0	0
	Turkey	Ankara	20	24	0.96	610

TABLE F-2

			Ground Snow	Frost Penetration (a)	Ground Snow	Frost Penetration (a)
Continent / Region	Country	Base / City	(psf)	(in)	(kPa)	(mm)
		Incirlik AB / Adana	0	5	0	127
		Izmir AS				
		Karamursel	15	12	0.72	305
Central America	Canal Zone		0	0	0	0
Europe	Belgium	Brussels				
		Kester				
		Kleine Brogel				
		Shape - Chievres				
	Bosnia - Herzegovina	Tulza AFB				
Europe	England	RAF Alconbury, Molesworth / Huntingdon				
		Birmingham	15	12	0.72	305
		RAF Croughton / Brackley	15	15	0.72	381
		RAF Fairford				
		RAF Lakenheath / Lakeheath Village	15	15	0.72	381
		USNA UK / London	15	12	0.72	305
		RAF Menwith Hill / Harrogate				
		RAF Mildenhall	15	12	0.72	305
		Plymouth	10	12	0.48	305
		RAF Upwood / Ramsey				
		JMF St. Mawgan / Cornwall				
		Sculthorpe AB	15	12	0.72	305

TABLE F-2

			Ground Snow	Frost Penetration (a)	Ground Snow	Frost Penetration (a)	
Continent / Region	Country	Base / City	(psf)	(in)	(kPa)	(mm)	
Europe	England	Southport	10	12	0.48	305	
		South Shields	15	12	0.72	305	
		Spurn Head	15	12	0.72	305	
	Germany	Ansbach					
		Bamberg					
		Baumholder					
		Bremen	25	30	1.2	762	
		Buechel Air Base / Cochem					
		Darmstadt					
		Garmisch AST					
		Geilenkirchen					
		Grafenwoehr	25	0	1.2	0	
		Hanau	25	25	1.2	635	
		Heidelberg	25	30	1.2	762	
		Hohenfels					
		Illesheim					
		Kaiserslautern					
		Kalkar					
		Mannheim					
		Munich	40	36	1.92	914	
Europe	Germany	Ramstein AB					
		Rhein-Main Air Base	25	30	1.2	762	
		Schweinfurt					
		Spangdahlem Air Base	25	30	1.2	762	
		Stuttgart	45	36	2.16	914	
		Vilseck					
		Wiesbaden / Mainz / Dexheim					

TABLE F-2

			Ground Snow	Frost Penetration (a)	Ground Snow	Frost Penetration (a)
Continent / Region	Country	Base / City	(psf)	(in)	(kPa)	(mm)
		Wuerzburg / Kitzingen / Giebelstadt	25	35	1.2	889
	Greece	Athens	5	0	0.24	0
		Larissa				
		NAS Soudi Bay / Mouzouras	5	0	0.24	0
	Iceland	Keflavik - NSA	30	24	1.44	610
	Iceland	Thorshofn	30	36	1.44	914
	Italy	Aviano AB	35	18	1.68	457
		Brindisi / San Vito	5	6	0.24	152
Europe	Italy	Camp Darby Livorno				
		Gaeta - NSA	20	0	0.96	0
		Ghedì				
		NSA La Maddalena	20	5	0.96	127
		NSA Naples	20	5	0.96	127
		Niscemi	20	5	0.96	127
		NAS Sigonella	20	5	0.96	127
		Vicenza	35	25	1.68	635
	Netherlands	Volkel Air Base				
		AF North Brunssum				
		Schinnen	15	20	0.72	508
	Northern Ireland	Londonderry	15	12	0.72	305
	Norway	Stavanger				
	Portugal	Azores / Lajes Field	0	0	0	0
		Southlant / Oeiras				
	Scotland	Aberdeen	15	12	0.72	305
		Edinburgh	15	12	0.72	305

TABLE F-2

Continent / Region	Country	Base / City	Ground Snow	Frost Penetration (a)	Ground Snow	Frost Penetration (a)
			(psf)	(in)	(kPa)	(mm)
Europe	Scotland	Edzell	15	12	0.72	305
		Glasgow	15	12	0.72	305
		Prestwick	15	12	0.72	305
		Stornoway	15	12	0.72	305
		Thurso	15	12	0.72	305
	Spain	Madrid / JHQ SW	10	6	0.48	152
		Moron AB				
		NS Rota	5	5	0.24	127
		San Pablo	5	6	0.24	152
		HRF Valencia				
	Zaragoza	10	6	0.48	152	
North America	Canada	Argentia NAS, Newfoundland	47	36	2.25	914
		Churchill, Manitoba	66	permafrost	3.16	permafrost
		Cold Lake, Alberta	41	72	1.96	1829
		Edmonton, Alberta	27	60	1.29	1524
		E. Harmon AFB, Newfoundland	86	60	4.12	1524
		Fort William, Ontario	73	60	3.5	1524
North America	Canada	Frobisher, NWT	50	permafrost	2.4	permafrost
		Goose Airport, Newfoundland	100	60	4.79	1524
		Ottawa, Ontario	60	48	2.87	1219
		St. John's, Newfoundland	72	36	3.45	914
		Toronto, Ontario	40	36	1.92	914
	Winnipeg, Manitoba	45	60	2.16	1524	

TABLE F-2

			Ground Snow	Frost Penetration (a)	Ground Snow	Frost Penetration (a)
Continent / Region	Country	Base / City	(psf)	(in)	(kPa)	(mm)
	Greenland	Narsarssuak AB	30	60	1.44	1524
		Simiutak AB	25	60	1.2	1524
		Sondrestrom AB	20	permafrost	0.96	permafrost
		Thule AB	25	permafrost	1.2	permafrost
Atlantic Ocean	Ascension Island		0	0	0	0
Caribbean Sea	The Bahamas	Eleuthera Island	0	0	0	0
		Grand Bahama Island	0	0	0	0
Caribbean Sea	The Bahamas	Grand Turk Island	0	0	0	0
		Great Exuma Island	0	0	0	0
	Cuba	NS Guantanamo Bay	0	0	0	0
	Trinidad Island	Port of Spain	0	0	0	0
Indian Ocean	British Indian Ocean Territory	NSF Diego Garcia	0	0	0	0
Pacific Ocean	Australia	H.E. Holt / N.W. Cape	0	0	0	0
		Darwin	0	0	0	0
		Woomera	0	0	0	0
	Caroline Islands	Koror, Paulau Islands	0	0	0	0
		Ponape	0	0	0	0
	Johnston Atoll		0	0	0	0
	Marcus Island		0	0	0	0
	Marshall Islands	Kwajalein	0	0	0	0
		Wake Island	0	0	0	0
Pacific Ocean	Midway Island		0	0	0	0

TABLE F-2

			Ground Snow	Frost Penetration (a)	Ground Snow	Frost Penetration (a)
Continent / Region	Country	Base / City	(psf)	(in)	(kPa)	(mm)
	Philippine Islands	Clark AFB	0	0	0	0
		Sangley Point	0	0	0	0
		Subic Bay	0	0	0	0
	Samoa	Apia / Upolu	0	0	0	0

Notes to TABLE F-2, “SNOW LOADING AND FROST PENETRATION DATA – OUTSIDE OF THE UNITED STATES, ITS TERRITORIES AND POSSESSIONS”

(a) – See best practice B-2.3 for footing depths considering frost.

CANCELLED

TABLE F-3 - EARTHQUAKE LOADING DATA – OUTSIDE OF THE UNITED STATES, ITS TERRITORIES AND POSSESSIONS

Table F-3

			Seismic Data (Site Class B)								
Continent / Region	Country	Base / City	PGA (%g)	S _s (%g)	S ₁ (%g)	S _{S,5/50} (%g)	S _{1,5/50} (%g)	S _{S,10/50} (%g)	S _{1,10/50} (%g)	S _{S,20/50} (%g)	S _{1,20/50} (%g)
Africa	Algeria	Algiers	38	101	48			53	25		
		Oran	24	63	30			33	16		
	Angola	Luanda	2	6	3			3	1		
	Benin	Cotonou	4	11	5			6	3		
	Botswana	Gaborone	1	3	1			1	1		
	Burkina Faso	Ougadougou	18	46	22			24	11		
	Burundi	Bujumbura	26	69	33			36	17		
	Cameroon	Douala	6	17	8			9	4		
		Yaounde	10	27	13			14	7		
	Central African Republic	Bangui	10	27	13			14	7		
	Chad	N'Djamena	2	6	3			3	1		
	Congo	Brazzaville	4	10	5			6	3		
	Democratic Republic of the Congo	Bukavu	30	78	37			41	19		
		Kinshasa	5	10	2			4	1		
		Lubumbashi	15	39	19			21	10		

Table F-3

			Seismic Data (Site Class B)									
Continent / Region	Country	Base / City	PGA	S _s	S ₁	S _{s,5/50}	S _{1,5/50}	S _{s,10/50}	S _{1,10/50}	S _{s,20/50}	S _{1,20/50}	
			(%g)	(%g)	(%g)	(%g)	(%g)	(%g)	(%g)	(%g)	(%g)	(%g)
Africa	Cote d'Ivoire	Abidjan	1	4	2			2	1			
	Djibouti	Djibouti	39	102	41			48	21			
	Egypt	Alexandria	Alexandria	9	24	12			12	7		
			Cairo	27	71	33			37	17		
			Port Said	26	68	32			36	17		
	Equatorial Guinea	Malabo	6	17	8			9	4			
	Eritrea	Asmara	17	45	21			24	11			
	Ethiopia	Addis Ababa	22	58	27			30	14			
	Gabon	Libreville	10	27	13			14	7			
	Gambia	Banjul	4	10	5			6	3			
	Ghana	Accra	14	37	18			20	9			
	Guinea	Conakry	14	38	18			20	9			
	Guinea-Bissau	Bissau	0.4	1	0.5			1	0.3			
	Kenya	Nairobi	12	32	15			17	8			
	Lesotho	Maseru	3	7	3			3	2			
	Liberia	Monrovia	9	22	11			12	6			
	Libya	Tripoli	23	60	28			31	15			
	Madagascar	Antananarivo	7	19	9			10	5			
Malawi	Blantyre	Blantyre	19	49	23			25	12			
		Lilongwe	11	28	13			15	7			
		Zomba	19	51	24			27	13			

Table F-3

			Seismic Data (Site Class B)								
Continent / Region	Country	Base / City	PGA	S _s	S ₁	S _{s,5/50}	S _{1,5/50}	S _{s,10/50}	S _{1,10/50}	S _{s,20/50}	S _{1,20/50}
			(%g)	(%g)	(%g)	(%g)	(%g)	(%g)	(%g)	(%g)	(%g)
Africa	Mali	Bamako	5	10	2			4	1		
	Mauritania	Nouakchott	3	8	4			4	2		
	Morocco	Casablanca	10	26	12			14	7		
		Kenitra	11	28	13			15	7		
		Rabat	10	27	13			14	7		
		Tangier	18	47	22			24	12		
	Mozambique	Maputo	4	11	5			6	3		
	Niger	Niamey	0.1	0.2	0.1			0.1	0.1		
	Nigeria	Ibadan									
		Kaduna	2	6	3			3	1		
		Lagos	0.1	0.3	0.1			0.1	0.1		
	Rwanda	Kigali	11	29	14			15	7		
	Senegal	Dakar	3	8	4			4	2		
	Sierra Leone	Freetown	14	37	17			19	9		
	Somalia	Mogadishu	4	10	5			6	3		
	South Africa	Cape Town	10	27	13			14	7		
		Durban	11	30	14			16	7		
		Johannesburg	1	3	1			2	1		
		Natal	3	7	3			4	2		
		Pretoria	1	3	1			2	1		
	Swaziland	Mbabane	7	19	9			10	5		

Table F-3

			Seismic Data (Site Class B)								
Continent / Region	Country	Base / City	PGA	S _s	S ₁	S _{s,5/50}	S _{1,5/50}	S _{s,10/50}	S _{1,10/50}	S _{s,20/50}	S _{1,20/50}
			(%g)	(%g)	(%g)	(%g)	(%g)	(%g)	(%g)	(%g)	(%g)
Africa	Tanzania	Dar es Salaam	7	18	8			9	4		
		Zanzibar	5	12	6			6	3		
	Togo	Lome	15	39	19			21	10		
	Tunisia	Tunis	36	95	45			50	24		
	Uganda	Kampala	18	46	22			24	11		
	Zambia	Lusaka	9	23	11			12	6		
	Zimbabwe	Harare	2	6	3			3	1		
Asia	Afghanistan	Bagram	66	146	84			73	35		
		Gardeyz	26	63	30			35	17		
		Herat	26	62	32			16	5		
		Jalalabad	45	106	39			59	21		
		Kabul	48	111	58			61	28		
		Kandahar	13	32	19			18	10		
		Lashkar Gah	7	16	11			9	5		
		Mazar-e Sharif	33	78	27			41	15		
		Pol-e Charkhi	42	100	47			57	26		
		Qalat	35	79	45			41	20		
	Bahrain	Manama	11	28	13			15	7		
		NSA Bahrain	12	32	15			17	8		
	Bangladesh	Dhaka	28	73	34			38	18		
	Brunei	Bandar Seri Begawan	15	39	18			20	10		

Table F-3

			Seismic Data (Site Class B)								
Continent / Region	Country	Base / City	PGA	S _s	S ₁	S _{s,5/50}	S _{1,5/50}	S _{s,10/50}	S _{1,10/50}	S _{s,20/50}	S _{1,20/50}
			(%g)	(%g)	(%g)	(%g)	(%g)	(%g)	(%g)	(%g)	(%g)
Asia	Burma	Mandalay	80	211	100			111	52		
		Rangoon	31	81	38			42	20		
	China	Beijing (Peking)	22	59	28			31	15		
		Chengdu	18	46	22			24	11		
		Chongqing	3	9	4			5	2		
		Guangzhou (Canton)	5	14	7			7	4		
		Harbin	5	13	6			7	3		
		Nanjing	9	25	12			13	6		
		Qingdao (Tsingtao)	13	33	16			17	8		
		Shanghai	7	18	9			10	5		
		Shenyang	35	93	44			49	23		
		Tianjin (Tientsan)	29	76	36			40	19		
		Wuhan	3	8	4			4	2		
	Hong Kong	Hong Kong	5	13	6			7	3		
	India	Bombay (Mumbai)	10	27	12			14	7		
		Calcutta (Kolkata)	20	52	25			28	13		
		Madras (Chennai)	6	15	7			8	4		
		New Delhi	28	74	35			39	18		
	Indonesia	Bandung	66	172	82			90	43		
		Jakarta	55	145	68			76	36		

Table F-3

			Seismic Data (Site Class B)								
Continent / Region	Country	Base / City	PGA	S _s	S ₁	S _{s,5/50}	S _{1,5/50}	S _{s,10/50}	S _{1,10/50}	S _{s,20/50}	S _{1,20/50}
			(%g)	(%g)	(%g)	(%g)	(%g)	(%g)	(%g)	(%g)	(%g)
		Medan	45	117	55			61	29		
Asia	Indonesia	Surabaya	39	101	48			53	25		
	Iran	Isfahan	36	95	45			50	24		
		Shiraz	69	182	86			95	45		
		Tabriz	72	190	90			100	47		
		Tehran	82	215	102			113	53		
	Iraq	Baghdad	50	130	70			68	38		
		Basra	39	103	49			54	26		
		Kirkuk	66	173	93			91	49		
	Israel	Haifa	55	144	68			75	36		
		Jerusalem	43	112	53			59	28		
		Tel Aviv	38	100	47			52	25		
	Japan	NAF Atsugi	75	196	93			103	49		
		Fukuoka	27	71	33			37	18		
		Itazuke AFB	29	77	36			40	19		
		MCAS Iwakuni	38	99	47			52	25		
		Iwo Jima	36	94	45			50	23		
		Kobe	76	199	94			104	49		
		Misawa AFB	50	130	69			68	36		
		Okinawa (All installations)	66	173	93			91	49		
		Osaka	71	187	88			98	46		

Table F-3

			Seismic Data (Site Class B)								
Continent / Region	Country	Base / City	PGA	S _s	S ₁	S _{s,5/50}	S _{1,5/50}	S _{s,10/50}	S _{1,10/50}	S _{s,20/50}	S _{1,20/50}
			(%g)	(%g)	(%g)	(%g)	(%g)	(%g)	(%g)	(%g)	(%g)
		Sagamihara	75	196	93			103	49		
Asia	Japan	Sapporo	40	105	50			55	26		
		Sasebo	36	95	45			50	23		
		Tokyo	75	196	93			103	48		
		COMFLTACT Yokosuka	75	196	93			103	49		
		Yokohama	75	196	93			103	49		
		Yokota AFB, Honshu	80	210	99			110	52		
		Camp Zama	75	196	93			103	49		
		Amman	28	74	35			39	18		
Kuwait	Ali Al Salem	10	25	12			13	6			
	Kuwait City	22	57	27			30	14			
Laos	Vientiane	22	57	27			30	14			
Lebanon	Beirut	60	157	74			82	39			
Malaysia	Kuala Lumpur	22	59	28			31	15			
Nepal	Kathmandu	98	258	122			135	64			
Oman	Areas south and west of Jabal Akehadar										
	- Ibri	36	96	45			51	23			
	- Nazwa	35	92	44			48	23			
	Batinah Coast										

Table F-3

			Seismic Data (Site Class B)								
Continent / Region	Country	Base / City	PGA	S _s	S ₁	S _{s,5/50}	S _{1,5/50}	S _{s,10/50}	S _{1,10/50}	S _{s,20/50}	S _{1,20/50}
			(%g)	(%g)	(%g)	(%g)	(%g)	(%g)	(%g)	(%g)	(%g)
		- Ash Shinash	66	174	82			91	43		
Asia	Oman	- Sib	52	136	64			72	34		
		- Suhar	60	157	74			83	39		
		Central, Southern, and Coastal Areas Sur to Sarfait									
		- Barik									
		- Dawqa	1	4	1			2	1		
		- Hayma									
		- Salalah	3	8	4			4	3		
		- Shalim									
		High Jabal Locations									
		- Miskin	43	113	53			59	27		
		- Sumail	43	112	53			59	28		
		- Rikshah	39	103	49			54	26		
		- Shaww	40	104	50			55	26		
		Kuria Muria Island									
		Masirah Island	8	20	10			10	5		
		Muscat	49	130	61			68	32		
		Mussandam Island	90	235	112			123	59		
		Madah	76	199	94			105	49		

Table F-3

			Seismic Data (Site Class B)								
Continent / Region	Country	Base / City	PGA	S _s	S ₁	S _{s,5/50}	S _{1,5/50}	S _{s,10/50}	S _{1,10/50}	S _{s,20/50}	S _{1,20/50}
			(%g)	(%g)	(%g)	(%g)	(%g)	(%g)	(%g)	(%g)	(%g)
	Pakistan	Islamabad	52	135	64			71	34		
Asia	Pakistan	Karachi	29	77	36			40	19		
		Lahore	47	123	58			64	30		
		Peshawar	42	110	52			58	27		
	Qatar	Doha	2	6	7			3	4		
	Saudi Arabia	Dhahran	4	10	5			6	3		
		Hafr al Batin	6	16	7			8	4		
		Jeddah	20	51	25			26	13		
		Jubail	14	37	17			20	9		
		Khamis Mushayt	2	6	2			3	1		
		Qadimah	10	25	12			13	7		
		Riyadh	2	6	7			3	4		
		Tabuk	11	29	14			15	8		
	Singapore	All	15	39	19			21	10		
	Sir Lanka	Colombo	1	3	1			1	1		
	South Korea	Camp Casey	6	16	7			8	4		
		Camp Hiialeah, Busan	12	31	15			17	8		
		Camp Humphreys / Pyongtaek	8	20	9			10	5		
		Chinhae	7	18	9			9	4		
		Kimhae	7	19	9			10	5		

Table F-3

			Seismic Data (Site Class B)								
Continent / Region	Country	Base / City	PGA	S _s	S ₁	S _{s,5/50}	S _{1,5/50}	S _{s,10/50}	S _{1,10/50}	S _{s,20/50}	S _{1,20/50}
			(%g)	(%g)	(%g)	(%g)	(%g)	(%g)	(%g)	(%g)	(%g)
		Kimpo AFB	6	16	7			9	4		
Asia	South Korea	Kunsan / Kunsan City	7	18	9			9	4		
		Kwangju	5	14	6			7	3		
		Osan AFB / Songtan	8	20	9			10	5		
		Pohang	6	15	7			8	4		
		Seoul	7	18	9			9	4		
		Taegu	12	30	14			15	8		
		Uijongbu	7	18	9			9	4		
		Yongsan / Seoul	7	18	9			10	4		
	Syria	Aleppo	26	68	32			35	17		
		Damascus	32	83	39			43	21		
	Taiwan	Changhua	110	288	136			151	71		
		Kao-hsiung	100	263	124			138	65		
		Tainan	96	251	119			132	62		
		Taipei	130	341	161			178	85		
		Tsoying	100	263	124			138	65		
	Thailand	Bangkok	11	29	14			15	8		
		Chiang Mai	11	29	13			15	7		
		Sattahip	8	22	11			12	5		
		Songkhla	12	31	15			16	8		
		Udonthani	10	25	12			13	7		

Table F-3

			Seismic Data (Site Class B)								
Continent / Region	Country	Base / City	PGA	S _s	S ₁	S _{s,5/50}	S _{1,5/50}	S _{s,10/50}	S _{1,10/50}	S _{s,20/50}	S _{1,20/50}
			(%g)	(%g)	(%g)	(%g)	(%g)	(%g)	(%g)	(%g)	(%g)
		Udon	10	25	12			13	6		
Asia	Turkey	Ankara	40	104	50			54	26		
		Incirlik AB / Adana	42	110	52			57	27		
		Istanbul	58	153	72			80	38		
		Izmir AS	97	254	120			133	62		
		Karamursel	56	146	69			77	36		
	United Arab Emirates	Abu Dhabi	43	112	53			59	28		
		Dubai	67	177	84			93	44		
	Vietnam	Da Nang	7	19	9			10	5		
		Ho Chi Minh City	6	15	7			8	4		
		Nha Trang	5	13	7			7	4		
Yemen	Aden City	15	38	18			20	9			
	Sanaa	14	36	17			19	9			
Central America	Belize	Belmopan	21	56	27			29	14		
		Canal Zone	37	97	46			51	25		
	Costa Rica	San Jose	112	294	139			154	73		
	El Salvador	San Salvador	68	179	85			94	44		
	Guatemala	Guatemala	67	177	83			93	44		
	Honduras	Tegucigalpa	40	105	50			55	26		
	Europe	Albania	Tirana	45	117	55			61	29	

Table F-3

			Seismic Data (Site Class B)								
Continent / Region	Country	Base / City	PGA (%g)	S _s (%g)	S ₁ (%g)	S _{s,5/50} (%g)	S _{1,5/50} (%g)	S _{s,10/50} (%g)	S _{1,10/50} (%g)	S _{s,20/50} (%g)	S _{1,20/50} (%g)
	Austria	Salzburg	17	44	21			23	11		
Europe	Austria	Vienna	20	52	24			27	13		
	Belgium	Antwerp	8	21	10			11	5		
		Brussels	13	34	16			18	8		
		Kester	14	38	17			20	9		
		Kleine Brogel	12	33	16			18	8		
		Shape - Chievres	22	57	27			30	14		
	Bosnia - Herzegovina	Tuzla AFB	37	97	46			51	23		
	Bulgaria	Sofia	47	122	58			64	30		
	Cyprus	Nicosia	47	124	59			65	31		
	Czech Republic	Prague	5	13	6			7	3		
	Denmark	Copenhagen	5	12	6			6	3		
	England	RAF Alconbury, Molesworth / Huntingdon	7	19	9			10	5		
		Birmingham	9	23	11			12	5		
		RAF Croughton / Brackley	11	29	14			15	8		
		RAF Fairford	6	17	7			9	4		
		RAF Lakenheath / Lakeheath Village	6	16	7			9	4		

Table F-3

			Seismic Data (Site Class B)								
Continent / Region	Country	Base / City	PGA	S _s	S ₁	S _{s,5/50}	S _{1,5/50}	S _{s,10/50}	S _{1,10/50}	S _{s,20/50}	S _{1,20/50}
			(%g)	(%g)	(%g)	(%g)	(%g)	(%g)	(%g)	(%g)	(%g)
		Liverpool	9	24	11			13	6		
Europe	England	USNA UK / London	5	13	4			7	1		
		RAF Menwith Hill / Harrogate	8	22	11			12	5		
		RAF Mildenhall	6	16	7			9	4		
		Plymouth	8	21	10			11	5		
		RAF Upwood / Ramsey	6	17	7			9	4		
		JMF St. Mawgan / Cornwall	8	21	5			11	3		
		Sculthorpe AB	6	17	7			9	4		
		Southport	9	24	12			13	7		
		South Shields	4	12	6			7	3		
		Spurn Head	6	17	7			9	4		
	Finland	Helsinki	2	5	2			3	1		
	France	Bordeaux	7	17	8			9	4		
		Istres AFB	14	38	18			20	9		
		Lyon	11	30	14			16	7		
		Marseille	18	47	22			24	12		
		Nice	17	43	20			23	11		
		Strasbourg	17	45	21			23	11		
	Germany	Ansbach	10	25	12			13	7		

Table F-3

			Seismic Data (Site Class B)								
Continent / Region	Country	Base / City	PGA	S _s	S ₁	S _{s,5/50}	S _{1,5/50}	S _{s,10/50}	S _{1,10/50}	S _{s,20/50}	S _{1,20/50}
			(%g)	(%g)	(%g)	(%g)	(%g)	(%g)	(%g)	(%g)	(%g)
		Babenhausen	14	36	17			19	9		
Europe	Germany	Bamberg	8	22	10			11	5		
		Baumholder	10	26	12			14	7		
		Berlin	2	5	2			3	1		
		Bonn	17	44	21			23	11		
		Bremen	4	10	5			6	3		
		Buechel Air Base / Cochem	13	34	16			18	9		
		Darmstadt	16	42	20			22	10		
		Dusseldorf	12	32	15			17	8		
		Frankfurt am Main	15	40	19			21	10		
		Garmisch AST	18	48	22			25	12		
		Geilenkirchen	22	58	27			30	14		
		Giebelstadt	9	23	11			12	6		
		Grafenwoehr	10	25	12			13	7		
		Hamburg	4	10	5			5	2		
		Hanau	15	40	19			21	10		
		Heidelberg	15	40	19			21	10		
Hohenfels	10	27	12			14	7				
Illesheim	9	24	12			12	7				
Kaiserslautern	10	26	12			14	7				
Kalkar	9	23	11			12	5				

Table F-3

			Seismic Data (Site Class B)										
Continent / Region	Country	Base / City	PGA	S _s	S ₁	S _{s,5/50}	S _{1,5/50}	S _{s,10/50}	S _{1,10/50}	S _{s,20/50}	S _{1,20/50}		
			(%g)	(%g)	(%g)	(%g)	(%g)	(%g)	(%g)	(%g)	(%g)	(%g)	
		Kitzingen	8	22	11			12	5				
Europe	Germany	Landstuhl	9	25	12			13	6				
		Mannheim	16	42	20			22	10				
		Munich	10	27	12			14	7				
		Ramstein AB	10	25	12			13	7				
		Rhein-Main Air Base	16	41	20			22	10				
		Schweinfurt	8	22	10			11	5				
		Spangdahlem Air Base	10	25	12			13	7				
		Stuttgart	18	46	22			24	12				
		Vaihingen an der Enz	15	41	19			21	10				
		Vilseck	9	23	11			12	5				
		Wiesbaden / Mainz / Dexheim	15	40	19			21	10				
		Wuerzburg / Kitzingen / Giebelstadt	8	22	11			12	5				
			Greece	Athens	32	85	40			44	21		
				Kavalla	43	114	54			60	28		
	Larissa	56		147	32			77	17				
	Nea Makri	35		91	43			48	22				
	Rhodes	55		144	68			75	36				

Table F-3

			Seismic Data (Site Class B)								
Continent / Region	Country	Base / City	PGA	S _s	S ₁	S _{s,5/50}	S _{1,5/50}	S _{s,10/50}	S _{1,10/50}	S _{s,20/50}	S _{1,20/50}
			(%g)	(%g)	(%g)	(%g)	(%g)	(%g)	(%g)	(%g)	(%g)
Europe	Greece	NAS Souda Bay / Mouzouras	48	126	42			66	22		
		Thessaloniki	57	149	70			78	37		
	Hungary	Budapest	19	49	23			25	12		
		Taszar AB	23	60	29			31	15		
	Iceland	Keflavik - NSA	40	105	50			55	26		
		Reykjavik	37	96	46			50	24		
		Thorshofn	20	51	24			26	13		
	Italy	Aviano AB	46	125	50			67	23		
		Brindisi / San Vito	7	21	13			13	7		
		Camp Darby Livorno	21	58	15			34	8		
		Florence	22	62	20			36	11		
		Gaeta - NSA	11	39	25			24	14		
		Genoa	12	35	11			20	5		
		Ghedi	27	75	19			41	10		
		NSA La Maddalena	9	24	12			13	7		
		Milan	8	27	7			16	4		
		NSA Naples	28	79	32			45	18		
		Niscemi	29	82	51			37	18		
	Palermo	30	84	26			46	14			
	Rome	16	52	19			32	10			

Table F-3

			Seismic Data (Site Class B)									
Continent / Region	Country	Base / City	PGA	S _s	S ₁	S _{s,5/50}	S _{1,5/50}	S _{s,10/50}	S _{1,10/50}	S _{s,20/50}	S _{1,20/50}	
			(%g)	(%g)	(%g)	(%g)	(%g)	(%g)	(%g)	(%g)	(%g)	(%g)
Europe	Italy	Siculiana	9	29	16			17	9			
		NAS Sigonella	55	139	92			64	31			
		Trieste	19	55	20			32	11			
		Turin	8	28	5			17	2			
		Vicenza	27	76	21			43	11			
	Luxembourg	Luxembourg	9	22	11			12	6			
	Malta	Valletta	11	30	14			16	7			
	Netherlands	Amsterdam	5	14	6			7	3			
		AF North Brunssum	22	58	27			31	14			
		Schinnen	2	6	7			3	4			
			Volkel Air Base	12	31	15			17	8		
	Northern Ireland	Belfast	3	9	4			5	2			
		Londonderry	3	8	4			4	3			
	Norway	Oslo	6	16	7			8	4			
		Stavanger	13	34	16			18	8			
Poland	Krakow	8	20	9			10	5				
	Poznan	2	6	3			3	1				
	Warszawa	5	12	6			6	3				
	Warsaw	4	11	5			6	3				
Portugal	Azores / Lajes Field	66	173	93			91	49				

Table F-3

			Seismic Data (Site Class B)								
Continent / Region	Country	Base / City	PGA	S _s	S ₁	S _{s,5/50}	S _{1,5/50}	S _{s,10/50}	S _{1,10/50}	S _{s,20/50}	S _{1,20/50}
			(%g)	(%g)	(%g)	(%g)	(%g)	(%g)	(%g)	(%g)	(%g)
Europe	Portugal	Lisbon	27	71	34			37	18		
		Oporto	26	68	32			35	17		
		Southlant / Oeiras	24	64	31			34	16		
	Republic of Ireland	Dublin	4	10	5			5	2		
	Romania	Bucharest	42	110	52			58	27		
	Russia	Moscow	3	7	3			4	2		
		St. Petersburg (Leningrad)	3	7	3			4	2		
	Scotland	Aberdeen	4	10	5			6	3		
		Edinburgh	7	18	9			9	4		
		Edzell	4	11	5			6	3		
		Glasgow	8	22	11			12	5		
		Hamilton	7	19	9			10	5		
		Prestwick	5	13	6			7	3		
		Renfrew	9	23	11			12	6		
		Stornoway	4	10	5			6	3		
		Thurso	4	9	4			4	3		
	Serbia and Montenegro	Belgrade	39	102	48			53	25		
		Zagrebac	42	109	52			57	27		
	Slovakia	Bratislava	22	59	28			31	15		
	Spain	Barcelona	24	63	30			33	16		

Table F-3

			Seismic Data (Site Class B)								
Continent / Region	Country	Base / City	PGA	S _s	S ₁	S _{s,5/50}	S _{1,5/50}	S _{s,10/50}	S _{1,10/50}	S _{s,20/50}	S _{1,20/50}
			(%g)	(%g)	(%g)	(%g)	(%g)	(%g)	(%g)	(%g)	(%g)
Europe	Spain	Bilbao	13	34	16			18	8		
		Madrid / JHQ SW	5	13	7			7	4		
		Moron AB	24	64	30			34	16		
		NS Rota	29	76	35			40	18		
		San Pablo	5	14	6			7	3		
		Sevilleja de la Jara	5	13	6			7	3		
		HRF Valencia	26	69	33			36	17		
		Zaragoza	6	16	7			9	4		
	Sweden	Goteborg	6	15	7			8	4		
		Stockholm	3	8	4			4	2		
	Switzerland	Bern	18	46	22			24	11		
		Geneva	19	49	23			25	12		
		Zurich	16	41	19			21	10		
	Ukraine	Kiev	3	7	3			4	2		
North America	Canada	Argentia NAS, Newfoundland	6	14	5			7	3		
		Calgary	9	12	3			6	2		
		Churchill, Manitoba	4	8	2			3	1		
		Cold Lake, Alberta	4	8	2			3	1		
		Edmonton, Alberta	4	8	2			3	1		

Table F-3

			Seismic Data (Site Class B)								
Continent / Region	Country	Base / City	PGA	S _s	S ₁	S _{s,5/50}	S _{1,5/50}	S _{s,10/50}	S _{1,10/50}	S _{s,20/50}	S _{1,20/50}
			(%g)	(%g)	(%g)	(%g)	(%g)	(%g)	(%g)	(%g)	(%g)
North America	Canada	E. Harmon AFB, Newfoundland	4	10	5			4	2		
		Fort William, Ontario	4	8	2			3	1		
		Frobisher, NWT	4	8	2			3	1		
		Goose Airport, Newfoundland	4	11	4			5	2		
		Halifax	9	19	6			9	3		
		Montreal	33	58	11			22	4		
		Ottawa, Ontario	32	57	11			22	4		
		St. John's, Newfoundland	6	14	5			7	3		
		Toronto, Ontario	12	18	5			8	2		
		Vancouver	49	101	31			46	16		
	Winnipeg, Manitoba	4	8	2			3	1			
	Greenland	Narsarssuak AB	12	33	17			18	9		
		Simiutak AB	12	33	17			18	9		
		Sondrestrom AB	9	23	11			12	5		
Thule AB		15	39	18			20	9			
Mexico	Ciudad Juarez	7	19	9			10	5			
	Guadalajara	59	154	73			81	38			
	Hermosillo	19	49	23			25	12			
	Matamoros	1	2	1			1	1			

Table F-3

			Seismic Data (Site Class B)								
Continent / Region	Country	Base / City	PGA	S _s	S ₁	S _{s,5/50}	S _{1,5/50}	S _{s,10/50}	S _{1,10/50}	S _{s,20/50}	S _{1,20/50}
			(%g)	(%g)	(%g)	(%g)	(%g)	(%g)	(%g)	(%g)	(%g)
North America	Mexico	Mazatlan	39	102	48			54	25		
		Merida	1	4	2			2	1		
		Mexico City	23	60	28			31	15		
		Monterrey	9	23	11			12	6		
		Nuevo Laredo	6	16	7			8	4		
		Tijuana	37	97	46			51	24		
South America	Argentina	Buenos Aires	21	38	8			15	4		
	Bolivia	La Paz	24	51	20			26	11		
	Brazil	Belem	1	1	0.3			1	0.3		
		Belo Horizonte	1	1	0.3			1	0.3		
		Brasilia	1	1	0.3			1	0.3		
		Manaus	8	21	7			5	1		
		Porto Alegre	1	1	1			1	0.3		
		Recife	4	11	4			4	1		
		Rio de Janeiro	1	4	2			1	1		
		Salvador	13	33	11			1	0.3		
		Sao Paulo	3	10	4			3	1		
		Chile	Santiago	94	221	102			131	60	
Valparaiso	132		316	141			187	82			
Colombia	Bogota	44	99	36			53	21			

Table F-3

			Seismic Data (Site Class B)								
Continent / Region	Country	Base / City	PGA	S _s	S ₁	S _{s,5/50}	S _{1,5/50}	S _{s,10/50}	S _{1,10/50}	S _{s,20/50}	S _{1,20/50}
			(%g)	(%g)	(%g)	(%g)	(%g)	(%g)	(%g)	(%g)	(%g)
South America	Ecuador	Guayaquil	81	190	84			111	48		
		Quito	90	212	82			102	45		
	Paraguay	Asuncion	3	7	3			4	1		
	Peru	Lima	95	230	98			134	56		
		Piura	97	232	103			134	59		
	Uruguay	Montevideo	18	32	7			13	3		
	Venezuela	Caracas	48	107	45			53	21		
		Maracaibo	43	93	39			45	18		
	Atlantic Ocean	Ascension Island									
Caribbean Sea	Bahamas	Eleuthera Island	1	2	1			1	1		
		Grand Bahama Island	1	2	1			1	1		
		Grand Turk Island	23	61	29			32	16		
		Great Exuma Island	8	20	10			11	5		
		Nassau	3	7	4			4	2		
	Barbados	Bridgetown	15	39	19			21	10		
	Cuba	Havana	10	27	13			14	7		
		NS Guantanamo Bay	50	132	62			69	33		
	Dominica	Roseau	43	113	53			59	28		

Table F-3

			Seismic Data (Site Class B)								
Continent / Region	Country	Base / City	PGA	S _s	S ₁	S _{s,5/50}	S _{1,5/50}	S _{s,10/50}	S _{1,10/50}	S _{s,20/50}	S _{1,20/50}
			(%g)	(%g)	(%g)	(%g)	(%g)	(%g)	(%g)	(%g)	(%g)
Caribbean Sea	Dominican Republic	Santo Domingo	69	182	86			95	45		
	Grenada	Saint George's	43	113	53			59	28		
	Guadeloupe	Basse-Terre	52	137	65			72	34		
	Haiti	Port-au-Prince	75	189	79			102	40		
		Cap-Haitien	58	150	60			91	37		
	Jamaica	Kingston	58	152	72			80	38		
	Martinique	Fort-de-France	39	102	48			54	25		
	Montserrat	Plymouth	65	170	81			89	42		
	Saint Croix	Frederiksted	32	84	30			44	16		
	Saint John	Bethany	43	117	41			66	23		
	Saint Kitts and Nevis	Basseterre	60	157	74			82	39		
	Saint Lucia	Castries	36	94	45			49	23		
	Saint Thomas	Charlotte Amalie	43	117	41			66	23		
	Saint Vincent and The Grenadines	Port Elizabeth	21	56	26			29	14		
	Trinidad & Tobago	Scarborough	45	117	55			61	29		
Trinidad NS		66	174	82			91	43			
Port of Spain		68	180	84			95	44			

Table F-3

			Seismic Data (Site Class B)								
Continent / Region	Country	Base / City	PGA	S _s	S ₁	S _{s,5/50}	S _{1,5/50}	S _{s,10/50}	S _{1,10/50}	S _{s,20/50}	S _{1,20/50}
			(%g)	(%g)	(%g)	(%g)	(%g)	(%g)	(%g)	(%g)	(%g)
Caribbean Sea	Vieques	Isabel Segunda	37	99	36			54	20		
Indian Ocean	British Indian Ocean Territory	NSF Diego Garcia	28	73	35			39	18		
Pacific Ocean	Australia	Brisbane	12	32	15			17	8		
		Canberra	19	49	23			26	12		
		Darwin	16	43	20			23	10		
		H.E. Holt / N.W. Cape	19	49	23			25	12		
		Melbourne	19	49	23			26	12		
		Perth	18	47	22			25	12		
		Sydney	18	46	22			24	11		
		Woomera	19	49	23			25	12		
	Caroline Islands	Koror, Paulau Islands	28	73	35			39	18		
		Ponape	41	108	51			56	27		
		Yap	31	82	39			43	20		
	Fiji	Suva	23	60	28			31	15		
	Johnston Atoll		54	143	67			75	35		
	Marcus Island		38	100	47			52	25		

Table F-3

			Seismic Data (Site Class B)								
Continent / Region	Country	Base / City	PGA	S _s	S ₁	S _{s,5/50}	S _{1,5/50}	S _{s,10/50}	S _{1,10/50}	S _{s,20/50}	S _{1,20/50}
			(%g)	(%g)	(%g)	(%g)	(%g)	(%g)	(%g)	(%g)	(%g)
Pacific Ocean	Marshall Islands	Majuro	49	127	60			67	32		
\2\		Kwajalein	14	32	9	22	6	14	4	9	2
/2/		Wake Island	55	144	68			75	35		
	Midway Island										
	New Zealand	Auckland	23	56	27			33	16		
		Wellington	72	172	82			101	48		
	Papau New Guinea	Port Moresby	31	82	39			43	20		
	Philippine Islands	Baguio	66	172	81			90	43		
		Cebu	46	120	57			63	30		
		Clark AFB	64	167	79			87	42		
		Manila	77	203	96			106	50		
		Sangley Point	78	204	97			107	51		
		Subic Bay	71	186	88			97	46		
	Saipan	Capitol Hill	58	178	45			92	23		
	Samoa	Apia / Upolu	13	33	15			17	8		
	Tinian		59	183	46			95	24		

\1\

Table F-3 Footnotes:

1 - SS,5/50 values can be interpolated via the following equations:

$$S_{s,5/50} = (S_{s,10/50})^{0.5642} \cdot (S_s)^{0.4358}.$$

$$S_{1,5/50} = (S_{1,10/50})^{0.5642} \cdot (S_1)^{0.4358}.$$

2 - Ss,20/50 values can be interpolated via the following equations:

$$S_{s,20/50} = (S_{s,10/50})^{1.4544} / (S_s)^{0.4544}.$$

$$S_{1,20/50} = (S_{1,10/50})^{1.4544} / (S_1)^{0.4544}.$$

/1/

CANCELLED

This page intentionally left blank.

CANCELLED

APPENDIX G SEISMIC SPECTRAL ACCELERATION MAPS AT SELECTED
LOCATIONS OUTSIDE OF THE UNITED STATES, ITS TERRITORIES AND
POSSESSIONS

FIGURE G-1 - AFGHANISTAN – RISK-TARGETED MAXIMUM CONSIDERED
EARTHQUAKE HORIZONTAL GROUND MOTION OF 0.2-SECOND SPECTRAL
RESPONSE ACCELERATION (5 PERCENT OF CRITICAL DAMPING), SITE CLASS
B

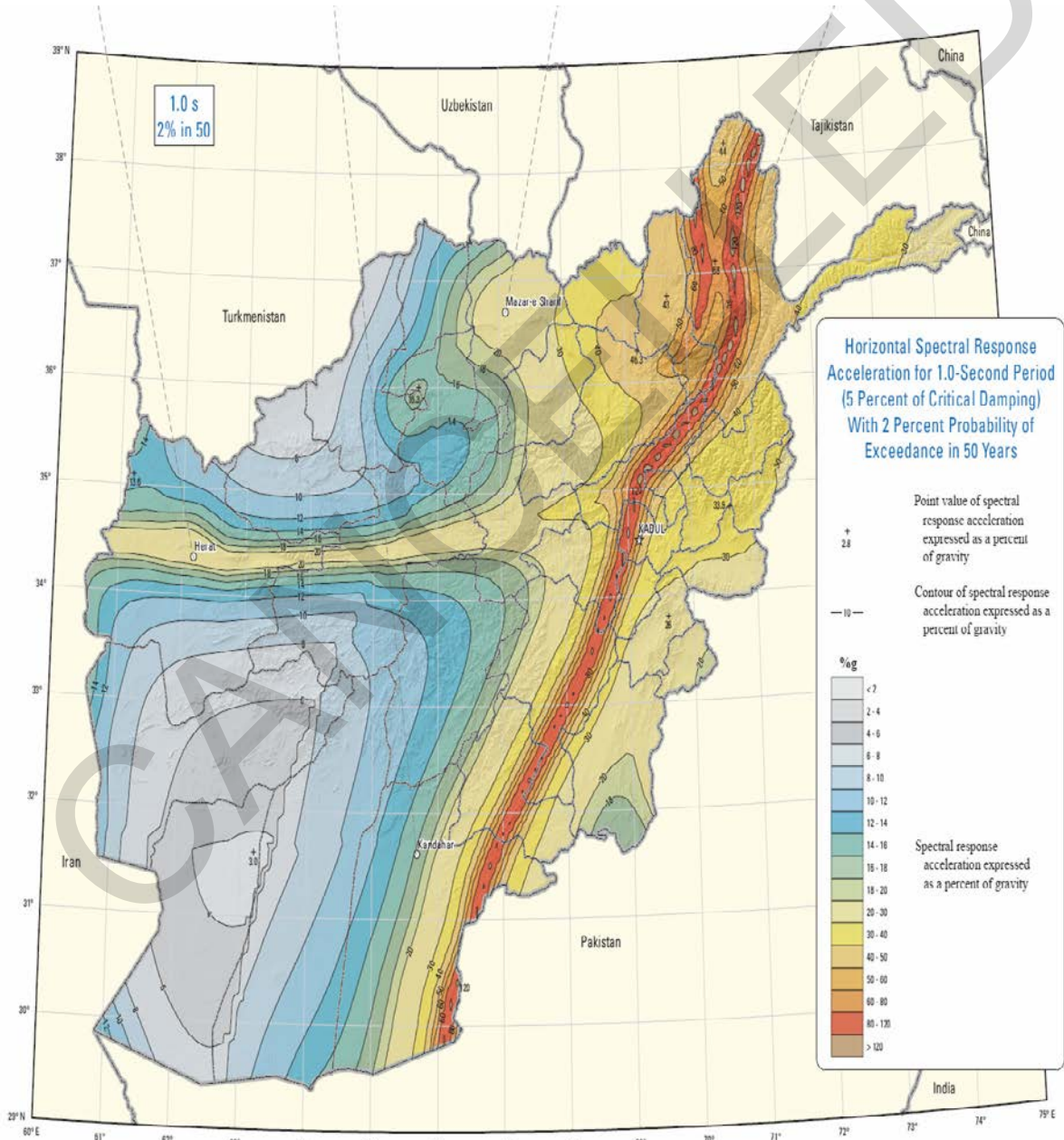

FIGURE G-2 - AFGHANISTAN – RISK-TARGETED MAXIMUM CONSIDERED EARTHQUAKE HORIZONTAL GROUND MOTION OF 1-SECOND SPECTRAL RESPONSE ACCELERATION (5 PERCENT OF CRITICAL DAMPING), SITE CLASS B

